

**Mihaela Florentina Niță**

Contributions to Aircraft Preliminary  
Design and Optimization

# **CONTRIBUTIONS TO AIRCRAFT PRELIMINARY DESIGN AND OPTIMIZATION**

POLITEHNICA University of Bucharest  
an institution authorized to organize doctoral programs

and

Hamburg University of Applied Sciences  
partner institution in the frame of the cooperative supervision process

*based on* the doctoral thesis successfully defended on 28.03.2012,  
and as to Order no. 5743 of 12.09.2012 issued by the  
Minister of Education, Research, Youth and Sports

for the attainment of the academic title of Doctor

by  
Mihaela Florentina Niță (Man)  
from Bucharest

## **Bibliografische Information der Deutschen Nationalbibliothek**

Die Deutsche Nationalbibliothek verzeichnet diese Publikation in der Deutschen Nationalbibliografie; detaillierte bibliografische Daten sind im Internet über <http://dnb.d-nb.de> abrufbar.

ISBN 978-3-8439-1163-4



© Verlag Dr. Hut, München 2013  
Sternstr. 18, 80538 München  
Tel.: 089/66060798  
[www.dr.hut-verlag.de](http://www.dr.hut-verlag.de)

**Die Informationen in diesem Buch wurden mit großer Sorgfalt erarbeitet. Dennoch können Fehler nicht vollständig ausgeschlossen werden. Verlag, Autoren und ggf. Übersetzer übernehmen keine juristische Verantwortung oder irgendeine Haftung für eventuell verbliebene fehlerhafte Angaben und deren Folgen.**

Alle Rechte, auch die des auszugsweisen Nachdrucks, der Vervielfältigung und Verbreitung in besonderen Verfahren wie fotomechanischer Nachdruck, Fotokopie, Mikrokopie, elektronische Datenaufzeichnung einschließlich Speicherung und Übertragung auf weitere Datenträger sowie Übersetzung in andere Sprachen, behält sich der Autor vor.

1. Auflage 2013

*In the memory of my grandfather*





# Preface

The reader will find the results of a work that never ceased to incite my passion for Aircraft Design and gave me the satisfaction of building a useful tool for the scientific community. Now, that I've come to the end of this work, I feel that this is only a beginning.

I remember what Prof. Dr.-Ing. Dănilă, the chairman of our Aerospace Engineering Department said, when he was leading a session of presentations of some of my Ph.D colleagues: "Doctoral studies represent a school – a place where students learn". Students are not suddenly experts just because they start the doctoral studies. Working on the dissertation is not only about reaching a certain degree of innovation. The experience gathered during the studies (the research work, the conferences, the interaction with specialists of the aviation community or the responsibility of guiding students) is an important asset, at least as important as the results provided at the end.

At the same time, the research effort opens enormous knowledge opportunities, and, for me, it meant the beginning of a deeper understanding of what Aircraft Design means.

The first person to whom I owe a great deal of knowledge accumulated during the research time is Prof. Dr.-Ing. Dieter Scholz. If it wasn't for his trust in me, I wouldn't have started this "school" in the first place. I would also like to thank him for the idea of publishing this work at Dr. Hut Verlag and for supporting me in improving the manuscript accordingly.

The support of Dr. -Ing. Mihai Neamțu was very important in creating a smooth advancement of my studies.

I enjoyed working in an international environment and guiding dedicated students involved in studies and theses that enriched this work with valuable contributions. I am also grateful for the opportunity of cooperating with industry.

This research would not have been possible without the financial support of the Romanian Ministry of Labor, Family and Social Protection through the Financial Agreement POSDRU/6/1.5/S/16, as well as the support of the ProExzellenzia Program, funded by the city of Hamburg and European Social Funds.



# Abstract

This work covers two related fields a) aircraft preliminary design and optimization, including aircraft cabin design and optimization and b) the optimization of engineering working processes in cabin design and cabin refurbishing. For a) existing equations or methods for aircraft preliminary sizing and conceptual design are adjusted and new equations or methods are introduced (e.g. equation for Oswald factor estimation, method for winglets efficiency estimation, method for estimating cabin length, method for estimating overhead stowage volume). Equations were combined to an Aircraft Design methodology. The methodology was implemented into Microsoft Excel to create a tool called *OPerA – Optimization in Preliminary Aircraft Design*. Optimization was initially done with a high-level commercial optimization software, Optimus®. A technique called Differential Evolution was selected to be programmed in Visual Basic for Applications (VBA) and integrated directly into OPerA. Four objective functions are selected: the classical minimizing of Direct Operating Costs (DOC) represented by equivalent ton-miles costs, minimizing fuel mass, minimizing maximum take-off mass and maximizing of a composed objective function DOC+AV consisting of a weighting of DOC and Added Values which are selected parameters responsible for additional revenues for an airline. For b) three alternatives are proposed to increase efficiency of cabin design activities: i) a partitioning algorithm delivers the sequence that minimizes information feedback, ii) the analysis of the eigenstructure of the matrix underlines those processes with the greatest influence on the engineering system, and iii) a cross impact analysis identifies groups of processes belonging to five spheres: reactive, dynamic, impulsive, low impact and neutral. The selected reference aircraft for optimization is the Airbus A320-200. Three additional versions of the aircraft are investigated: a version with braced wings, a version with natural laminar flow and a version having both innovations at the same time. A number of 24 combinations of aircraft and cabin parameters, as well as requirements are tested for each objective function and each aircraft version. Varying aircraft and cabin parameters and adding the two innovations braced wings and natural laminar flow delivered these improvements: reduces DOC by about 16 %, maximum take-off mass by 24 %, fuel mass by 50 % and increases DOC+AV by 48 %. The tool provided is an efficient Aircraft Design tool, producing traceable optimizations in Preliminary Aircraft Design. It can be used in teaching as well as in the research of conventional and innovative configurations. Optimizing process chains for cabin redesign activities is not only beneficial, but also helps demonstrating required design and certification capabilities to aeronautical authorities.

# Extended Abstract

## The Task

This work covers two related fields a) aircraft preliminary design and optimization, including aircraft cabin design and optimization and b) the optimization of engineering working processes in cabin design and cabin refurbishing. Aircraft preliminary design is defined here as aircraft Preliminary Sizing and Conceptual Design. Optimization in this work is a) the task of finding optimal aircraft and aircraft cabin parameter combinations and b) the task of finding the optimal sequence of engineering work processes in Cabin Conversions.

## The Method

For a) aircraft preliminary design and optimization existing equations or methods for aircraft preliminary sizing and conceptual design are adjusted and new equations or methods are introduced (e.g. equation for Oswald factor estimation, method for winglets efficiency estimation, method for estimating cabin length, method for estimating overhead stowage volume, proposal of new mission fuel fractions). Equations were combined to an Aircraft Design methodology that ensured a balanced view on benefits and penalties of changing values of design parameters. The methodology was implemented into Microsoft Excel to create a preliminary design and optimization tool, called *OPerA – Optimization in Preliminary Aircraft Design*. OPerA uses a two-layered optimization strategy: an automated, intrinsic requirements matching in a two-dimensional chart represents the first layer that delivers the design point, and a formal optimization, representing the second layer, for the search of the optimum combination among a maximum of 20 design variables. Formal optimization was initially done with a high-level commercial optimization software, Optimus®. The tool enables the application of all relevant optimization algorithms to the Aircraft Design methodology OPerA. A technique called Differential Evolution from the Evolutionary class of optimization algorithms was selected to be programmed in Visual Basic for Applications (VBA) and integrated directly into OPerA. Its efficiency is proven to be equal to Optimus®.

For the formal design optimization four objective functions are selected: the classical minimizing of Direct Operating Costs (DOC) represented by equivalent ton-miles costs, minimizing fuel mass, minimizing maximum take-off mass and maximizing of a composed objective function “DOC plus Added Values” consisting of a weighting of DOC and Added Values, which are selected parameters responsible for additional revenues for an airline. Weighting factors are calculated based on an expert questioning. Cabin parameters such as seat pitch or aisle width are included into the optimization in order to understand their impact on the design.

For b) engineering work processes and their relations are transformed into a square matrix. Three alternatives are proposed to increase efficiency of later stage cabin design activities: i) a partitioning algorithm delivers the sequence that minimizes information feedback, ii) the

analysis of the eigenstructure of the matrix underlines those processes with the greatest influence on the engineering system, and iii) a cross impact analysis identifies groups of processes belonging to five spheres: reactive, dynamic, impulsive, low impact and neutral.

### **Numerical Results**

The selected reference aircraft for optimization is the Airbus A320-200. Three additional versions of the aircraft are investigated: a version with braced wings, a version with natural laminar flow and a version having both innovations at the same time. A number of 24 combinations of aircraft and cabin parameters, as well as requirements are tested for each objective function and each aircraft version.

Varying only design parameters (while keeping cabin standards and aircraft performance requirements constant) delivered these improvements compared to the reference aircraft A320: DOC reduced by 3.2 %, maximum take-off mass reduced by 3.4 %, fuel mass reduced by 14.5 %, the objective “DOC plus Added Values” score increased from 4.5 to 6.1 out of 10. Setting requirements free to allow a higher design freedom and allowing simultaneous optimization of cabin and fuselage parameters increases the optimization potential compared to the more restricted design approach. Adding cabin parameters to the optimization runs indicates on average a further improvement of 6.2 % for every objective. Adding both cabin parameters and setting requirements free, brings an improvement of 12 % on average for every objective. Adding also the two innovations (braced wings and natural laminar flow) simultaneously reduces DOC by about 16 %, maximum take-off mass by 24 %, fuel mass by 50 % compared to the reference aircraft A320 and increases “DOC plus Added Values” up to a score of 9.3 out of 10.

### **Lessons learnt**

The potential of engine by-pass ratio is increased by slower speeds and lower altitudes. Winglets are beneficial if span is limited; they proved to be less efficient than increasing span. The effect of braced wings upon the design is higher than the effect of natural laminar flow. By favoring a lower sweep, braced wings enable natural laminar flow, so the cumulative effect of both innovations should be considered.

### **Conclusions**

The main conclusion of this study is that finding optimal parameter combinations already during the initial design stage helps assessing the design potential and the cost at which improvements may be produced given a set of requirements. The tool provided is an efficient Aircraft Design tool, producing traceable optimizations in Preliminary Aircraft Design. It can be used in teaching as well as in the research of conventional and innovative configurations.

Optimizing process chains for cabin redesign activities is not only beneficial, but also helps demonstrating required design and certification capabilities to aeronautical authorities.



# Table of Content

<b>Abstract</b>	iii
<b>Extended Abstract</b>	viii
<b>List of Figures</b>	xv
<b>List of Tables</b>	xviii
<b>List of Abbreviations</b>	xxi
<b>List of Symbols</b>	xxiv
<b>1 Introduction</b>	1
1.1 Motivation and Title Terminology	1
1.2 Background	2
1.3 Research Questions and Objectives	5
1.4 Previous Research	7
1.4.1 Software Tools for Aircraft Design	8
1.4.2 Aircraft Design Optimization	13
1.5 Structure of the Work	15
<b>2 Methodology for Aircraft Preliminary Sizing and Conceptual Design</b>	19
2.1 Sizing from Requirements and Statistics	19
2.1.1 Landing Distance and Approach Speed	20
2.1.2 Take-off Distance	21
2.1.3 Second Segment Climb and Missed Approach Climb Gradient	21
2.1.4 Cruise Mach Number	22
2.1.5 Combining Requirements in a Matching Chart	23
2.1.6 Estimating Relative Operating Empty Mass	25
2.1.7 Estimating Relative Fuel Mass	26
2.1.8 Calculating Basic Aircraft Parameters	27
2.2 Refinement of the Aircraft Sizing and Conceptual Design Methodology	27
2.2.1 Estimating the Oswald Factor for Conventional Configurations	28
2.2.2 Estimating the Oswald Factor for Non-Planar Configurations	34
2.2.3 Estimating a Refined Zero-Lift Drag from Wetted Area, Form Factor and Interference Drag	44
2.2.4 Estimating Maximum Lift-to-Drag Ratio	47
2.2.5 Discussion on Natural Laminar Flow	48
2.2.6 Discussion on Strut Braced Wings	51
2.2.7 Estimating Thrust Specific Fuel Consumption	57
2.2.8 Estimating Landing Gear Parameters and Mass	61
2.2.9 Estimating other Aircraft Parameters	65
2.3 Identifying Key Design Variables for Optimization	70



<b>3</b>	<b>Methodology for Cabin and Fuselage Preliminary Sizing and Conceptual Design</b> .....	71
3.1	Sizing from Requirements and Statistics .....	71
3.2	Refinement of the Cabin Sizing and Conceptual Design Methodology .....	72
3.2.1	Estimating Basic Parameters .....	72
3.2.2	Estimating Baggage and Cargo Volume .....	75
3.2.3	Estimating Cargo Compartment Height .....	77
3.2.4	Estimating the Cargo Hold Accessibility Factor from Sill Height .....	79
3.3	Identifying Key Design Variables for Optimization .....	80
<b>4</b>	<b>Methodology Calibration and Testing</b> .....	81
4.1	Iterations in Aircraft Design Methodology .....	81
4.2	Handling Un-convergence and Ensuring Tool Stability .....	82
4.3	Design Space .....	83
4.4	Calibration Test and Correction Factors .....	84
4.5	Constraints .....	86
4.6	Tool Particularities and Limitations .....	87
4.7	Case Study: Redesign of Future A320 NEO Aircraft .....	89
<b>5</b>	<b>Brief Theoretical Background on Optimization and Algorithms Selection</b> ...	92
5.1	Introduction .....	93
5.2	Gradient and Non Gradient Based Categories of Optimization Algorithms .....	94
5.3	Non-Gradient Based Category of Optimization Algorithms.....	95
5.4	The Class of Evolutionary Algorithms .....	97
5.5	Class and Algorithm Selection .....	99
5.6	Optimization Software Optimus® .....	101
<b>6</b>	<b>Implementation of Selected Algorithms in OPerA</b> .....	103
6.1	Single Parameter Optimization with DOE Diagonal .....	103
6.2	Single and Multiple Parameters Optimization with Differential Evolution .....	104
6.2.1	Description .....	104
6.2.2	Implementation.....	105
6.2.3	Convergence Improvement .....	108
<b>7</b>	<b>Description of OPerA: Tool for Preliminary Design and Optimization of Aircraft and Cabin Parameters</b> .....	109
7.1	Spreadsheet Based Aircraft and Cabin Sizing.....	111
7.2	Description of OPerA – Optimization in Preliminary Aircraft Design.....	112
7.3	Optimization with OPerA.....	117
7.3.1	The VBA Module .....	119
7.3.2	The Connection with Optimus® .....	119
7.3.3	The MS Excel Solver .....	120

<b>8</b>	<b>Objective Functions</b> .....	123
8.1	Classical Objectives .....	123
8.2	Added Values in Aircraft Design Optimization .....	124
8.2.1	Low and High Boundaries of Added Values.....	126
8.2.2	Questionnaires Evaluation.....	127
8.2.3	Results of Questionnaires Evaluation.....	135
8.2.4	Selection of Final Weights .....	138
8.2.5	Building the Objective Function .....	140
8.2.6	Summary .....	140
8.2.7	Conclusions and Lessons Learnt .....	141
<b>9</b>	<b>Optimization Results</b> .....	143
9.1	Parameters and Parameter Combinations.....	143
9.2	Optimization for Minimum DOC.....	150
9.2.1	Case A: Standard Configuration .....	150
9.2.2	Case B: Configuration with Braced Wings .....	152
9.2.3	Case C: Configuration with Natural Laminar Flow on Wings .....	153
9.2.4	Case D: Configuration with Braced Wings and Natural Laminar Flow on Wings.....	154
9.3	Optimization for Minimum $m_{MTO}$ .....	155
9.3.1	Case A: Standard Configuration .....	155
9.3.2	Case B: Configuration with Braced Wings .....	156
9.3.3	Case C: Configuration with Natural Laminar Flow on Wings.....	157
9.3.4	Case D: Configuration with Braced Wings and Natural Laminar Flow on Wings.....	158
9.4	Optimization for Minimum $m_F$ .....	159
9.4.1	Case A: Standard Configuration .....	159
9.4.2	Case B: Configuration with Braced Wings .....	160
9.4.3	Case C: Configuration with Natural Laminar Flow on Wings.....	161
9.4.4	Case D: Configuration with Braced Wings and Natural Laminar Flow on Wings.....	162
9.5	Optimization for Maximum DOC and Added Values Composed Function .....	163
9.5.1	Case A: Standard Configuration.....	163
9.5.2	Case B: Configuration with Braced Wings .....	164
9.5.3	Case C: Configuration with Natural Laminar Flow on Wings.....	165
9.5.4	Case D: Configuration with Braced Wings and Natural Laminar Flow on Wings.....	166
9.6	Influence of Cabin Parameters .....	167
9.7	Other Interesting Results .....	171
<b>10</b>	<b>Cabin Design and Conversion in Industry</b> .....	175
10.1	A Process Chain for Cabin Design.....	177

10.2	Cabin Design by Aircraft Manufacturers .....	179
10.3	Cabin Conversion by Completion Centers .....	180
10.4	A Process Chain for Cabin Conversion .....	182
10.5	Tools in Cabin Design and Conversion .....	185
10.6	Market Forecast for Cabin Conversion .....	187
10.7	Certification of Aircraft Cabins .....	194
<b>11</b>	<b>Optimization of the Process Chain for Cabin Conversions</b> .....	<b>200</b>
11.1	Process Chain Representation Models .....	201
11.1.1	Flow Charts .....	201
11.1.2	Matrix Representation .....	203
11.1.3	Concurrent Engineering Concept .....	205
11.2	Dependency and Structure Modeling Optimization Methodology .....	207
11.2.1	Types of DSMs and Their Application .....	207
11.2.2	Optimization Algorithms.....	210
11.3	Analysis of the DSM for the Process Chain for Cabin Conversion .....	213
11.3.1	Partitioning Algorithm .....	213
11.3.2	Eigenstructure Analysis.....	214
11.3.3	Cross Impact Analysis .....	216
<b>12</b>	<b>Conclusions and Summary of Contributions</b> .....	<b>220</b>
12.1	Overview .....	221
12.2	Summary of Theoretical Contributions .....	222
12.3	Conclusions on OPerA – Optimization in Preliminary Aircraft Design .....	224
12.4	Conclusions on Optimization Results .....	225
<b>13</b>	<b>Outlook</b> .....	<b>227</b>
	<b>List of Publications</b> .....	<b>230</b>
	<b>List of References</b> .....	<b>232</b>
	<b>Appendix A Database of Aircraft and Aircraft Data</b> .....	<b>259</b>
	<b>Appendix B Questionnaire for Added Values</b> .....	<b>261</b>
	<b>Appendix C The Elements of the Process Chain for Cabin Conversions</b> .....	<b>263</b>
	<b>Appendix D Market Forecast Methodology for Cabin Modifications</b> .....	<b>268</b>

# List of Figures

<b>Fig. 1.1</b>	Aircraft development process (black blocks) and aircraft modification process (grey blocks).....	4
<b>Fig. 1.2</b>	Structure of the work.....	18
<b>Fig. 2.1</b>	An example of a matching chart. The grey point is the design point .....	24
<b>Fig. 2.2</b>	Typical flight mission .....	26
<b>Fig. 2.3</b>	Function $f(\lambda)$ from Equation (2.27).....	31
<b>Fig. 2.4</b>	Calculated Oswald factor ( $e_{calc}$ ) and Mach number correction ( $ke_M$ ) from Prandtl-Glauert (PG) and own estimation method (without further index), compared with Oswald factor calculated for A320 aircraft ( $e_{A320}$ ).....	34
<b>Fig. 2.5</b>	Simple geometrical consideration for winglets evaluation .....	35
<b>Fig. 2.6</b>	$A / A_{eff}$ as a function of $h/b$ , from different authors .....	36
<b>Fig. 2.7</b>	Increase in span due to winglets as a function of drag reduction in cruise, with data from <b>Boeing 2002, Airbus 2012</b> .....	37
<b>Fig. 2.8</b>	Geometrical representation of the wing with dihedral .....	38
<b>Fig. 2.9</b>	Span efficiency for various optimally loaded non-planar systems ( $h / b = 0.2$ ) ...	39
<b>Fig. 2.10</b>	The factor $k$ as a function of $h/b$ ratio for a box wing from different literature sources and own calculations .....	42
<b>Fig. 2.11</b>	$e_{box} / e_{ref}$ for a box wing as a function of $h/b$ ratio calculated from iDrag results fit to “Box Wing Equation” (2.46) resp. (2.48) and “Winglet Equation” (2.43) .....	43
<b>Fig. 2.12</b>	Laminar flow limits for swept wings .....	50
<b>Fig. 2.13</b>	TSFC model based on <b>Torenbeek 1986</b> and <b>Herrmann 2010</b> .....	59
<b>Fig. 2.14</b>	TSFC as a function of BPR for the A320 aircraft obtained with Herrmann’s model in OPerA .....	61
<b>Fig. 2.15</b>	Parameters for estimating landing gear lengths .....	61
<b>Fig. 2.16</b>	Tail strike may occur in two points: either in point A – Figure a.) or in point B – Figure b.) .....	62
<b>Fig. 3.1</b>	Diagram showing, for selected aircraft, the relation between the number of passengers and fuselage slenderness, $\lambda_F$ , with number of seats abreast as parameter.....	73
<b>Fig. 3.2</b>	Accessibility factor as a function of sill height .....	79
<b>Fig. 4.1</b>	Parameter and parameter groups in OPerA.....	83
<b>Fig. 4.2</b>	Matching chart for a 10 parameters optimization scenario. In case a.) $V / V_{md}$ is automatically found by forcing the cruise line to match the design point (grey). In case b.) $V / V_{md}$ is an optimization variable. Here, the cruise line freely results to be very close to the design point. ....	87
<b>Fig. 5.1</b>	Decomposition of the two main categories of optimization approaches into classes and eventually optimization algorithms .....	96
<b>Fig. 5.2</b>	An example of an active workflow window in Optimus® .....	101
<b>Fig. 6.1</b>	The DOE Diagonal algorithm explores the design space by evaluating the objective function in equally distributed points within the design space interval. ....	103

<b>Fig. 6.2</b>	Standard Differential Evolution algorithm.....	106
<b>Fig. 6.3</b>	VBA and Optimus® results for Direct Operating Costs optimization.....	107
<b>Fig. 6.4</b>	Impact of the combination factor $KF$ on convergence .....	108
<b>Fig. 6.5</b>	Impact of $KF$ and $F$ on the convergence .....	109
<b>Fig. 7.1</b>	Structure of OPerA .....	113
<b>Fig. 7.2</b>	“Optimization Set-up” module in OPerA with two optimization approaches ....	118
<b>Fig. 7.3</b>	The Optimus® toolbar in Excel and the Data IO menu .....	120
<b>Fig. 7.4</b>	The Excel interface with Optimus®.....	121
<b>Fig. 8.1</b>	Sidewall clearance: Clearance between armrest and sidewall. Graphic extracted from <i>PreSTo</i> . .....	125
<b>Fig. 8.2</b>	Conversion of optimization values into points.....	126
<b>Fig. 8.3</b>	Required number of evaluations as a function of the size of the matrix .....	128
<b>Fig. 8.4a</b>	Example of filled in matrix and the corresponding reciprocal matrix .....	130
<b>Fig. 8.4b</b>	Normalized reciprocal matrix corresponding to the example of filled matrix, continuation of Figure 8.4a. ....	131
<b>Fig. 8.5</b>	Random consistency index as a function of matrix size based on the estimation method for $\lambda_{max,av} = f(n)$ .....	132
<b>Fig. 8.6</b>	Comparison of linear and reciprocal scales.....	133
<b>Fig. 9.1</b>	Representation of experiment A15-DOC, where cruise Mach number is varied	145
<b>Fig. 9.2</b>	Representation of experiment A4-DOC, where sweep angle is varied.....	148
<b>Fig. 9.3</b>	Representation of experiment A3-DOC, where the two lift coefficients for landing and take-off configuration (for unswept wing) are varied .....	149
<b>Fig. 9.4</b>	Representation of experiment A17- $m_{MTO}$ , where take-off and landing as well as cruise requirements are varied.....	149
<b>Fig. 9.5</b>	The resulting matching chart for the case A11a-DOC.....	150
<b>Fig. 9.6</b>	Improvement of each objective with increasing level of technology compared to the baseline aircraft. Each plot shows how much each of the four parameters, for each of the four case studies, is minimized ( $m_{MTO}$ , $m_F$ , DOC), respectively maximized (DOC+AV) compared to “A320 base”, situated at 100 %.....	172
<b>Fig. 9.7</b>	Improvement of objective function DOC with increasing design freedom .....	173
<b>Fig. 10.1</b>	Cabin layout obtained with <i>Pacelab Cabin</i> tool .....	179
<b>Fig. 10.2</b>	Completion Center concepts .....	181
<b>Fig. 10.3</b>	Process chain concept for cabin conversions .....	183
<b>Fig. 10.4</b>	Passenger key growth rates .....	190
<b>Fig. 10.5</b>	Cabin modification world volume 2009-2029 .....	191
<b>Fig. 10.6</b>	International Cabins: Cabin Retrofit World Distribution 2009-2029 .....	191
<b>Fig. 10.7</b>	Domestic Cabins: Cabin Retrofit World Distribution 2009-2029.....	192
<b>Fig. 10.8</b>	Aircraft on Operating Lease: Cabin Retrofit World Distribution 2009-2029.....	193
<b>Fig. 10.9</b>	Pax-to-Freighters Conversion: World Distribution 2009-2029.....	194
<b>Fig. 10.10</b>	Preparation for DOA implementation – Process Chain representation.....	199
<b>Fig. 11.1</b>	Design Structure Matrix in contrast to a direct graph (digraph) .....	204
<b>Fig. 11.2</b>	Configuration possibilities of the interrelations between tasks .....	205

<b>Fig. 11.3</b>	Example of DSM showing the relations between the main phases of the process chain for cabin conversion .....	207
<b>Fig. 11.4</b>	Classification of DSM .....	208
<b>Fig. 11.5</b>	DSMs and DMMs for the five project domains .....	210
<b>Fig. 11.6</b>	The partitioned matrix obtained from the original matrix shown in Figure 11.3	212
<b>Fig. 11.7</b>	The partitioned DSM resulted after running the partitioning algorithm on the original DSM .....	214
<b>Fig. 11.8</b>	Work Transformation Matrix (WTM) .....	215
<b>Fig. 11.9</b>	Cross Impact Matrix example .....	217
<b>Fig. 11.10</b>	Cross Impact Diagram .....	217
<b>Fig. 11.11</b>	The Cross-Impact Diagram based on the DSM.....	218
<b>Fig. C.1</b>	Coding system used for the process illustration.....	263
<b>Fig. C.2</b>	Process illustration: Offer Phase .....	264
<b>Fig. C.3</b>	Process illustration: Concept Phase.....	265
<b>Fig. C.4</b>	Process illustration: Definition Phase.....	266
<b>Fig. C.5</b>	Process illustration: Design Phase.....	266
<b>Fig. C.6</b>	Process illustration: Certification Phase.....	267
<b>Fig. C.7</b>	Process illustration: Hand-Over Phase .....	267
<b>Fig. C.8</b>	Process illustration: Adjustment Phase .....	267

# List of Tables

<b>Table 2.1</b>	Requirements, inputs and outputs in Preliminary Sizing .....	24
<b>Table 2.2</b>	Summary of literature study (1 of 2 Tables) .....	30
<b>Table 2.3</b>	Summary of literature study (1 of 2 Tables) .....	30
<b>Table 2.4</b>	$k_{e,F}$ and $k_{e,D_0}$ factors for each aircraft category .....	33
<b>Table 2.5</b>	The $k_{WL}$ factor obtained from different authors .....	37
<b>Table 2.6</b>	Aerodrome reference codes and wing span limitations .....	38
<b>Table 2.7</b>	$k_{NP}$ calculated for each non-planar configuration from <b>Kroo 2005</b> .....	40
<b>Table 2.8</b>	The factors $k_1, k_2, k_3, k_4$ and factor $k$ when $h/b$ reaches extremes from different literature sources and own considerations.....	42
<b>Table 2.9</b>	Values for surface roughness .....	45
<b>Table 2.10</b>	Form factors for each component that contributes to zero-lift drag .....	45
<b>Table 2.11</b>	Interference factors for each component that contributes to zero-lift drag.....	46
<b>Table 2.12</b>	Wetted areas for each component that contributes to zero-lift drag .....	46
<b>Table 2.13</b>	Potential percentage of NLF and total drag reduction calculated at $M = 0.7$ for a business jet .....	48
<b>Table 2.14a</b>	Authors researching the strut-braced wing configuration and their main conclusions .....	52
<b>Table 2.14b</b>	Authors researching the strut-braced wing configuration (continuation).....	53
<b>Table 2.14c</b>	Authors researching the strut-braced wing configuration (continuation) .....	54
<b>Table 2.14d</b>	Authors researching the strut-braced wing configuration (continuation).....	55
<b>Table 2.15</b>	Engines found on medium range aircraft and their TSFC values used as reference for comparing the approaches of different authors for estimating TSFC .....	57
<b>Table 2.16</b>	Evaluation of methods for estimating TSFC. Selection of the best method.....	58
<b>Table 2.17</b>	Comparison of TSFC models.....	59
<b>Table 2.18</b>	Evaluation of the Herrmann model.....	60
<b>Table 2.19</b>	Evaluation of available landing gear mass estimation methods .....	64
<b>Table 2.20</b>	Values for the derivatives in Equation (2.80) .....	66
<b>Table 2.21</b>	Gamma ranges for swept and unswept wing aircraft from own statistic.....	66
<b>Table 2.22</b>	Gamma ranges for swept and unswept wing aircraft from <b>Raymer 1999</b> .....	66
<b>Table 2.23</b>	Selected statistical factors and equations determined for integration in OPerA.....	69
<b>Table 2.24</b>	Key Preliminary Sizing variable for optimization .....	70
<b>Table 3.1</b>	A list of cabin parameters and their typical values .....	73
<b>Table 3.2</b>	Proposal of number of trays per passenger, based on data from references <b>Markwardt 1998, AFPO 2006</b> and <b>Schmitt 1988</b> .....	75
<b>Table 3.3</b>	Values for the $S_{OS,lat}$ , $S_{OS,ce}$ and $k_{OS}$ for selected aircraft with 1 or 2 aisles.....	77
<b>Table 3.4</b>	Statistical factor for cargo compartment height evaluation .....	78
<b>Table 3.5</b>	Parameters for estimating cargo compartment height .....	78
<b>Table 4.1</b>	Start values of key-parameters for the iteration loops .....	82
<b>Table 4.2</b>	Optimization variables in OPerA.....	84

<b>Table 4.3</b>	Parameters of the A320 aircraft, as resulted from the redesign with OPerA.....	85
<b>Table 4.4</b>	Correction factors in OPerA as set for the calculations in this work based on the A320 as reference aircraft .....	85
<b>Table 4.5</b>	Improvements of NEO compared to original A320 aircraft .....	90
<b>Table 4.6</b>	Implementation of NEO improvements in OPerA.....	90
<b>Table 5.1</b>	Summary of properties for gradient and non-gradient based algorithms .....	95
<b>Table 5.2</b>	Selection of the optimization algorithm.....	100
<b>Table 6.1</b>	Algorithms of the Optimization Module in OPerA .....	103
<b>Table 6.2</b>	Best DOC values obtained with different $KF$ factors .....	108
<b>Table 6.3</b>	Impact of $KF$ and $F$ on the convergence.....	109
<b>Table 7.1</b>	Advantages and disadvantages of using MS Excel as a platform for developing OPerA.....	112
<b>Table 7.2</b>	Possible combination cases for estimating $E_{max}$ implemented in OPerA .....	117
<b>Table 8.1</b>	Added Values selected for inclusion in OPerA .....	125
<b>Table 8.2</b>	Examples of Added Values boundaries .....	127
<b>Table 8.3</b>	Linear scale and reciprocal scale	
<b>Table 8.4</b>	Normalized eigenvector for the example matrix in Fig. 3.....	129
<b>Table 8.5</b>	Linear and reciprocal scales.....	133
<b>Table 8.6</b>	Example results of one questionnaire and its evaluation .....	134
<b>Table 8.7</b>	Averages of key evaluation parameters .....	136
<b>Table 8.8</b>	Group averages of Added Values main hierarchical breakdown.....	136
<b>Table 8.9</b>	Group averages of Added Values (scaled to 100 %) form Hierarchical Table (page 1) and from AHP linear (page 2).....	138
<b>Table 8.10</b>	Attributed weights to the Added Values.....	139
<b>Table 8.11</b>	Attributed weights to the Added Value and score calculation for the composed objective function .....	140
<b>Table 9.1</b>	List of aircraft and cabin optimization variables and their values for the reference aircraft.....	144
<b>Table 9.2</b>	Low and high boundaries set for each variable in the optimization process ....	144
<b>Table 9.3a</b>	Optimization cases for standard configuration starting from A320-200 baseline. XXX in Case ID stands for: DOC – Direct Operating Costs, MTO – maximum take-off mass, MF – fuel mass, DOC+AV – Direct Operating Costs and Added Values .....	146
<b>Table 9.3b</b>	Optimization cases for standard configuration starting from A320-200 baseline (continuation) .....	147
<b>Table 9.4</b>	Results of experiment A11a-DOC .....	150
<b>Table 9.5</b>	Results of experiment A20b-DOC.....	152
<b>Table 9.6</b>	Results of experiment B20b-DOC .....	153
<b>Table 9.7</b>	Results of experiment C20b-DOC.....	154
<b>Table 9.8</b>	Results of experiment D20b-DOC.....	155
<b>Table 9.9</b>	Results of experiment A20b-MTO .....	156
<b>Table 9.10</b>	Results of experiment B20b-MTO.....	157



<b>Table 9.11</b>	Results of experiment C20b-MTO.....	158
<b>Table 9.12</b>	Results of experiment D20b-MTO .....	159
<b>Table 9.13</b>	Results of experiment A20b-MF .....	160
<b>Table 9.14</b>	Results of experiment B20b-MF.....	161
<b>Table 9.15</b>	Results of experiment C20b-MF.....	162
<b>Table 9.16</b>	Results of experiment D20b-MF .....	163
<b>Table 9.17</b>	Results of experiment A20b-DOC+AV.....	164
<b>Table 9.18</b>	Results of experiment B20b-DOC+AV .....	165
<b>Table 9.19</b>	Results of experiment C20b-DOC+AV .....	166
<b>Table 9.20</b>	Results of experiment D20b-DOC+AV.....	167
<b>Table 9.21</b>	The influence of cabin parameters on the objective function minimum DOC .	169
<b>Table 9.22</b>	Cabin parameters when optimizing for minimum DOC and when optimizing for maximum DOC+AV (experiment 20b, case A).....	169
<b>Table 9.23</b>	Benefit over burden for cabin parameters.....	170
<b>Table 9.24</b>	Values of cabin parameters for different technologies, for objectives minimum DOC and maximum DOC+AV .....	171
<b>Table 9.25a</b>	List of additional outputs for study cases 1 to 12 (except case 7), objective minimum DOC .....	174
<b>Table 9.25b</b>	List of additional outputs for study cases 13 to 20, objective minimum DOC	175
<b>Table 10.1</b>	Categories of tools and selection criteria.....	186
<b>Table 10.2</b>	Driving factors for international, domestic cabins and aircraft on operating lease .....	188
<b>Table 11.1</b>	Comparison of common process modeling methodologies .....	203
<b>Table 11.2</b>	Interaction quantification scheme .....	209
<b>Table 11.3</b>	Main characteristics of DSMs and DMMs .....	210
<b>Table 11.4</b>	Comparison between DSM and DMM .....	213
<b>Table 11.5</b>	The processes with the largest eigenvalues .....	215
<b>Table 11.6</b>	Results for the parameters describing the Cross-Impact diagram .....	217
<b>Table 11.7</b>	Selected processes for each zone of influence.....	219
<b>Table A.1</b>	Amount of aircraft used to evaluate existing estimation methods for the Oswald factor.....	259
<b>Table A.2</b>	List of aircraft and aircraft characteristics .....	259

# List of Abbreviations

ACARE	Advisory Council for Aeronautical Research in Europe
ACMG	Air Cargo Management Group
ACT	Additional Center Tank
AHP	Analytic Hierarchy Process
AIAA	The American Institute of Aeronautics and Astronautics
AP	Airbus Procedure
ATT	Additional Tail Tank
AV	Added Values
BPR	By-Pass Ratio
BPMN	Business Process Modeling Notation
BWB	Blended Wing Body
CAD	Computer Aided Design
CAE	Computer Aided Engineering
CAMR	Center for Advanced Manufacturing
CC	Completion Center
CF	Cross Flow instability
CFD	Computational Fluid Dynamics
CG	Center of Gravity
CI	Consistency Index
CIDS	Cabin Intercommunication Data System
CLB	Climb
COC	Cash Operating Costs
CPM	Critical Path Method
CR	Crossover Rate; Consistency Ratio
CS	Certification Specifications
CVE	Compliance Verification Engineer
DE	Differential Evolution
DO	Design Organization
DOA	Design Organization Approval
DOC	Direct Operating Costs
DOE	Design of Experiments
DMM	Domain Mapping Matrix
DSM	Design Structure Matrix
EA	Evolutionary Algorithms
EASA	European Aviation Safety Agency
EP	Evolutionary Programming
EPC	Event-driven Process Chains
ERP	Enterprise Resources Planning
ES	Evolution Strategies
FAA	Federal Aviation Administration

FAL	Final Assembly Line
FAR	Federal Aviation Regulations
FEA	Finite Elements Analysis
GA	Genetic Algorithms
HLF	Hybrid Laminar Flow
ICAO	International Civil Aviation Organization
IDEF	Integrated Definition
IFE	In-Flight Entertainment
JAA	Joint Aviation Authorities
LCC	Low-Cost Careers
LHD	Latin Hypercube Design
MAD	Multidisciplinary Analysis and Design Center (for Advanced Vehicles)
MCA	Major Component Assembly
MDM	Multiple Domain Matrix
MDO	Multidisciplinary Optimization
ME	Mimetic Algorithms
NASA	National Aeronautics and Space Administration
NEO	New Engine Option
NLF	Natural Laminar Flow
OAPR	Overall Pressure Ratio
OBS	Organizational Breakdown Structure
OoA	Office of Airworthiness
PDM	Product Data Management
PERT	Program Evaluation and Review Technique
PLM	Product Lifecycle Management
PMM	Process Module Methodology
PW	Pratt & Whitney
RBS	Resources Breakdown Structure
RI	Random Consistency Index
RPK	Revenue Passenger Kilometers
RS	Response Surface
RSM	Response Surface Modeling
SADT	Structured Analysis and Design Technique
SAE	Self Adaptive Evolution
SBW	Strut Braced Wing
SFC	Specific Fuel Consumption
SP	Seat Pitch
ST	Strut
STC	Supplemental Type Certificate
TC	Type Certificate
TBD	To Be Defined
TET	Turbine Entry Temperature

TO	Take-off
T-S	Tollmien-Schlichting instability
TSCF	Thrust Specific Fuel Consumption
UML	unified Modeling Language
URL	Uniform Resource Locator
VBA	Visual Basic for Applications
VIP	Very Important Person
W	Weight
WBS	Work Breakdown Structure
WTM	Work Transformation Matrix
XML	Extensible Markup Language
XPDL	XML Process Definition Language

# List of Symbols

## Latin Symbols

$a$	correction factor for calculating the Oswald factor
$A$	aspect ratio; vector
$b$	wing span; correction factor for calculating the Oswald factor
$B$	Breguet range factor; vector
$c$	chord; friction coefficient
$C$	coefficient (drag, lift); slope; coefficient for determining the Oswald factor; friction coefficient; vector
$CR$	crossover rate
$d$	diameter
$D$	drag
$e$	Oswald factor (span efficiency factor)
$E$	lift-to-drag ratio
$FF$	form factor
$g$	gravitational acceleration
$G$	gas generator function
$h$	altitude; height of the non-planar element
$k$	span efficiency factor ( $k = 1/e$ ); correction factor for calculating the Oswald factor; factor for calculating the Oswald factor for aircraft with winglets, with dihedral and for box wing aircraft; statistical factor; indicator of surface roughness
$K$	factor for calculating the viscous term for determining the Oswald factor; term for calculating the Oswald factor; Gust alleviation factor
$KF$	combination factor
$l$	characteristic length (for calculating the Reynolds number)
$L$	lift; length
$m$	mass; slope of the polar; partial mission fuel fractions; evaluations
$M$	Mach number; mission
$N, n$	number of engines; load factor; number of parameters
$P$	viscous drag factor
$p$	pressure
$p(h)$	pressure as a function of altitude
$q$	factor for calculating the Oswald factor
$Q$	inviscid drag factor; interference factor
$R$	leading edge suction parameter; range; coefficient of determination
$Re$	Reynolds number
$s$	factor for calculating the inviscid term for determining the Oswald factor, it corrects the inviscid term for the fuselage influence
$S$	relative leading edge suction force; thrust; range; landing or take-off distance; area
$SP$	seat pitch
$t$	thickness (floor, skin, lining panel, isolation, frame, floor)

$t/c$	wing thickness ratio
$u$	factor for calculating the inviscid term for determining the Oswald factor, with the significance of a theoretical Oswald factor
$U$	gust velocity
$v$	factor for calculating the twist terms in the drag estimation
$V$	speed
$w$	factor for calculating the twist terms in the drag estimation; width
$X, x$	vector or element of a vector
$Y, y$	vector or element of a vector

### **Greek Symbols**

$\alpha$	angle of attack
$\beta$	compressibility factor; factor for calculating the Oswald factor
$\gamma$	ratio of specific heats
$\Gamma$	dihedral angle
$\delta$	span efficiency factor ( $\delta = 1/e - 1$ )
$\Delta$	deviation; difference
$\varphi$	sweep angle
$\phi$	dimensionless turbine entry temperature
$\kappa$	airfoil technology factor
$\lambda$	taper ratio
$\Lambda$	aspect ratio
$\nu$	kinematic viscosity; ratio between stagnation point temperature and temperature
$\mu$	factor for calculating the Oswald factor; dynamic viscosity; mass ratio
$\eta$	profile efficiency; spanwise position of center of pressure; kink ratio; efficiency
$\pi$	Pi number
$\rho$	air density
$\sigma$	relative pressure
$\theta$	twist angle; angle of the landing gear geometry (see Figure 2.16)
$\tau$	relative thickness ratio
$\chi$	temperature function

### **Indices**

$A$	airfoil
$APP$	approach
$av$	average
$box$	box wing
$comp$	compressibility
$CP$	center of pressure
$CR$	cruise
$crit$	critical
$D$	drag

<i>DD</i>	drag divergence
<i>DE</i>	index for gust velocity
<i>D<sub>i</sub></i>	induced drag
<i>D<sub>i,invicid,twist</sub></i>	inviscid drag, that accounts also for twist influence
<i>D<sub>0</sub></i>	zero lift drag
<i>e</i>	Oswald factor (span efficiency factor); leading edge (suction force); Euler number
<i>E</i>	engines
<i>eff</i>	effective
<i>f</i>	friction
<i>F</i>	fuselage; fuel; weight factor
<i>ff</i>	fuel fraction
<i>FL</i>	flaps
<i>GE</i>	ground - engine (designating the engine ground clearance)
<i>geo</i>	geometrical
<i>H</i>	horizontal
<i>i</i>	induced; counter of flight segments
<i>inviscid</i>	inviscid
<i>K</i>	kink
<i>KB</i>	keel beam
<i>L</i>	lift; landing
<i>L<sub>α</sub></i>	lift curve slope
<i>LE</i>	leading edge
<i>LER</i>	leading edge radius
<i>LFL</i>	landing field length
<i>lim</i>	limit
<i>L,max,L</i>	lift, maximum landing
<i>L,max,TO</i>	lift, maximum take-off
<i>m</i>	medium
<i>M</i>	Mach number
<i>MAC</i>	mean aerodynamic chord
<i>max</i>	maximum
<i>md</i>	minimum drag
<i>MG</i>	main gear
<i>min</i>	minimum
<i>misc</i>	miscellaneous
<i>ML</i>	maximum landing
<i>MTO</i>	maximum take-off
<i>MZF</i>	maximum zero-fuel
<i>N</i>	nacelle
<i>NG</i>	nose gear
<i>NP</i>	non-planar
<i>OE</i>	operating empty

<i>opt</i>	optimum
<i>P</i>	pylon
<i>PAX</i>	passenger
<i>PL</i>	payload
<i>prel</i>	preliminary
<i>r</i>	root; rows
<i>ref</i>	reference
<i>S</i>	space (from Breguet range equation); stall
<i>SA</i>	seats abreast
<i>SH</i>	sill height
<i>ST</i>	strut
<i>t</i>	tip; position on chord where the transition from laminar to turbulent takes place
<i>T</i>	transition; tire
<i>theor</i>	theoretical
<i>TO</i>	take-off
<i>TOFL</i>	take-off field length
<i>tot</i>	total
<i>V</i>	vertical
<i>W</i>	wing
<i>wet</i>	wetted
<i>WL</i>	winglet
<i>WT</i>	wheel track
<i>0</i>	initial
<i>0,1,2,3,4</i>	identification number
<i>25</i>	referring to 25 % of the chord





# 1 Introduction

## 1.1 Motivation and Title Terminology

Aircraft Design in industry is first of all based on accumulated experience. Optimization is less used. The design of a new aircraft is often closely derived from previous aircraft already built by the manufacturer. This follows also from the need to avoid development risks. The aircraft configuration mostly stays the same and similar design methods and parameters are used.

Unfortunately, in this fashion, not all available possibilities for an improvement of the product are used. Formal optimization could be a solution to this problem because a computer is not biased towards a particular solution. It is however of highest importance that the optimization does not come from a "black box". Instead, the results from the optimization must be easy to interpret. Only in this way confidence for the formal solution can be established starting from the design engineer up to management.

This very observation was made by Prof. Dr. Dieter Schmitt (Vice President, Research and Future Projects Airbus, retired). In **Schmitt 2009** he made an important statement about Aircraft Design of commercial aircraft:

*"There is little use of optimization and optimization tools in industry!  
The understanding of a solution, the transparency of the solution  
is of prime importance to achieve credibility."*

Optimization should start with the Preliminary Design stage. The optimal combinations of basic design parameters should already be found in the initial design stage before reaching the level of detail design (**Amadori 2008**). During initial design a great number of configurations need to be evaluated to find the best design from a large set of investigated alternatives.

Many Aircraft Design books propose the following Aircraft Design stages: *Conceptual Design*, *Preliminary Design* and *Detail Design* (**Raymer 1999**, **Brandt 1997**, **Torenbeek 1986**, **Jenkinson 1999**, **Kundu 2010**, **Howe 2000**). Some authors (**Loftin 1980**, **Roskam 1989a**, **Scholz 1999**) emphasize the importance of aircraft Preliminary Sizing and they represent it as a separate stage, which is the basis for the Conceptual Design of the entire aircraft.

In view of this work, **Aircraft Preliminary Design** comprises of aircraft *Preliminary Sizing* and *Conceptual Design*. These two terms are not always consistently defined in literature. Here, the following meanings are attributed:

*Preliminary Sizing* is the process of determining an initial set of basic aircraft parameters, based only on the requirements given by the aircraft mission. The resulting basic parameters are: take-off mass, fuel mass, operating empty mass, wing area and take-off thrust.

*Conceptual Design* is based on Preliminary Sizing which facilitates the finding of additional parameters for every aircraft component (wing, fuselage, and empennage); during Conceptual Design, initial mass and drag estimations are performed; stability and control requirements are accounted for when sizing the empennage, and finally, a 3-view-drawing of the resulting aircraft configuration is delivered.

**Optimization of Aircraft Preliminary Design** means achieving a rational and interpretable parameter combination that optimizes a predefined objective function.

This work brings meaningful contributions for setting a balanced compendium of equations for Aircraft Preliminary Design. A maximum number of 20 parameters are optimized using an evolutionary technique. The approach is materialized by creating a simple but realistic tool, which allows design space exploration and traceability of results in an original way: an intrinsic requirements chart-wise matching integrated into formal optimization.

Besides aircraft parameters, such as aspect ratio, or by-pass ratio, the formal optimization integrates cabin parameters, which usually are neglected during initial design stage. Contributions are brought also in the area of Cabin Conversions, which have a very high economic importance during the aircraft life. This topic was researched during the doctoral studies in the frame of a university-industry cooperation project.

## 1.2 Background

Over the years, the engineering design process has never ceased to keep its iterative nature. Lately, the result of the iterative design process needs to cope with the additional demand of shorter and less expensive design cycles. One way to satisfy this increasing demand is the use of formal optimization. The increase in computational power enabled the development of optimization algorithms and changed the way iterations are performed. **Verstraete 2008** states: “If a few decades ago, a new design was based on previous experience, prototypes, expert knowledge and testing in experimental facilities, nowadays methods and tools that allow rapid design iterations on machine environment are developed.”

Nevertheless, the engineering design task becomes very difficult when:

- the amount of parameters increases,
- the effect of their relationship is difficult to assess.

Optimization algorithms have improved over the last decades. Engineers can make use of them to solve their problems. Algorithms have become more flexible and can be tailored to meet specific requirements of robustness or computational time.

Preliminary Aircraft Design can and must, too, benefit from this computational evolution. The mission of Preliminary Aircraft Design is to narrow the design space of an aircraft corresponding to the requirements, up to the point where detail design is feasible. The two initial steps, mentioned in the previous section – Preliminary Sizing and Conceptual Design – can and should make use of formal optimization along this narrowing process. *This idea will be the corner stone on which this work will build.*

Preliminary Sizing and Conceptual Design are part of the *Project Phase* of aircraft development. *Definition* and *Development* phases, follow the Project Phase, and will not be dealt with here. Figure 1.1 (inspired by **Brandt 1997** and **Scholz 1999**) illustrates the Aircraft Design and Manufacturing stages.

A separate, third stage, is part of the aircraft life: the *Modification Phase*, which is indicated in grey in Figure 1.1, and often misses from a design process chart. Cabin Design is the main tool for an airline to differentiate among competitors. This is the reason why during the aircraft life, the cabin design suffers multiple changes and is regularly refurbished.

Cabin parameters are not given enough emphasis during initial design stage. In this work cabin parameters are considered when optimizing the aircraft preliminary design. This work also approaches the Cabin Conversion processes and formulates a mathematical solution for optimizing the work flow. Sections 10 and 11 cover the Modification Phase of the Aircraft Design. These results are part of a university-industry cooperation project, called CARISMA - Aircraft Cabin and Cabin System Refurbishing - Optimization of Technical Processes.

The industry interest on the topic Cabin Conversions, part of aircraft Modification Phase, the enormous amount of work invested in CARISMA and the interesting, practical results obtained on the topic of optimizing aircraft redesign processes, were reasons to include this topic under the main topic of this work.

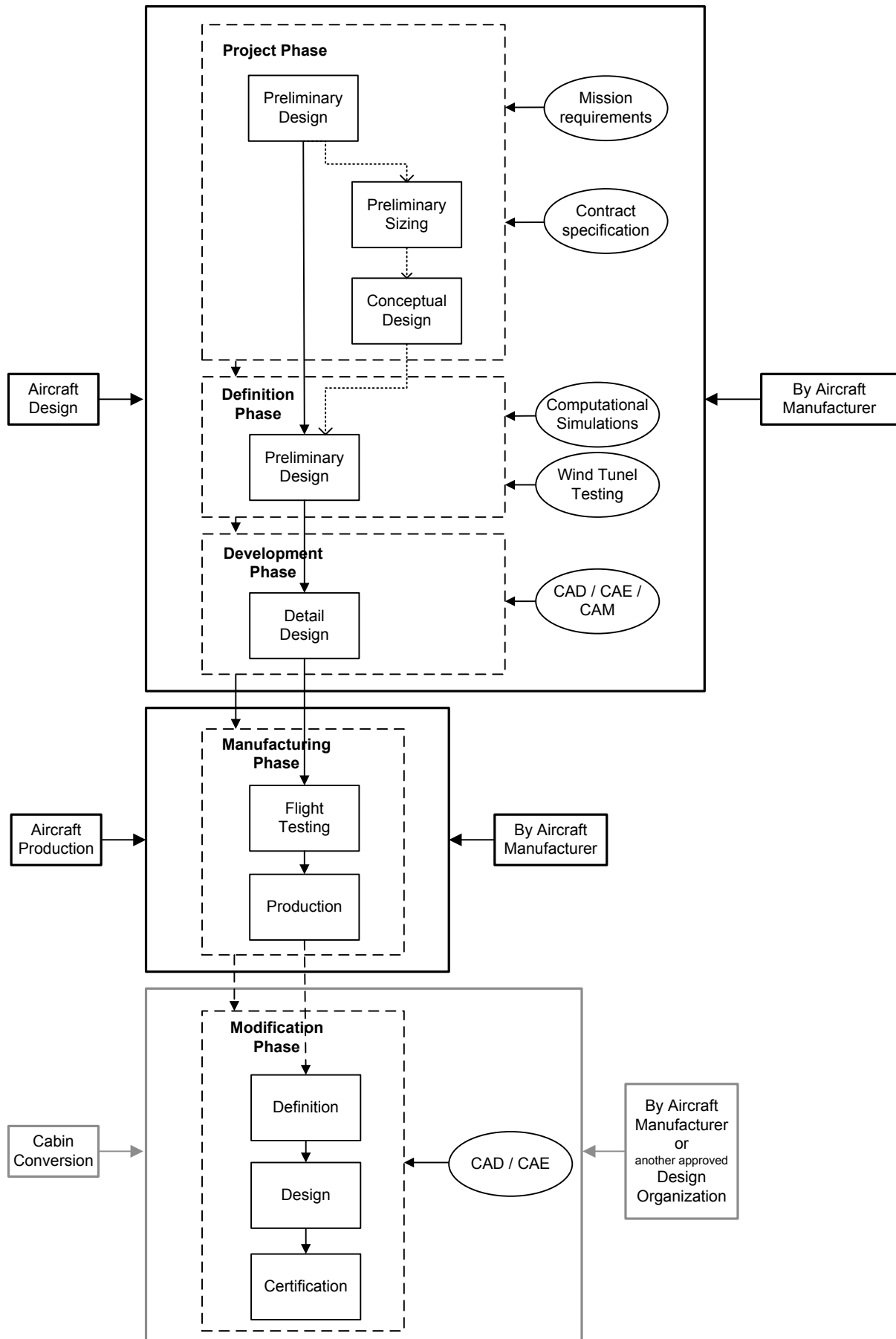

**Fig. 1.1** Aircraft development process (black blocks) and aircraft modification process (grey blocks)

The chart in Figure 1.1 may be adapted according to the experience and own considerations of each designer, as there is not a single answer to this.

During *Project Phase*, based on limited information, the main parameters best meeting the mission requirements and contract specifications are estimated. The purpose at this stage is to explore as many solutions as possible and to narrow the feasible concepts to one or very few layouts. *This is the reason why Preliminary Sizing and Conceptual Design represent key steps*, as key features of the future aircraft are now decided.

During *Definition Phase* the selected concepts are looked at in more detail. Simulations are performed, subsystems are defined and ultimately the design is ‘frozen’. This phase very much depends on the previous phase. If the Project Phase was carried out successfully, then very little changes to the layout need to be made during the preliminary design. *This indicates the importance of optimization at the very beginning of aircraft design.*

The *Development Phase* ensures the detailed definition of the entire design. Only aircraft that have been decided to be produced reach this design stage. During this phase, more accurate simulations and tests are performed. *Any mistake made in the previous phases cannot be corrected anymore.* Again, the importance of initial optimization is to be remarked.

Once the detail design is over, *Flight Testing* is performed to confirm the computational results and to certify the Type Design. If no issues occur, *Production* may begin.

Following production, the aircraft enters into service and it is taken over by airlines. Regularly, airlines decide to change or upgrade the outfit of the cabin. During the *Modification* phase the cabin changes are defined, designed and certified. The approval to perform changes to an existing design is given by the certification authorities only to those Design Organizations (usually different than the aircraft manufacturer) that prove this capability. As such, optimization of their process chain is vital.

### **1.3 Research Questions and Objectives**

#### *Question 1*

*Which values of the basic parameter combination in the initial design stage leads to an optimum aircraft design and through what means can these values be found?*

The approach towards finding the answer to this two folded question is driven by the following objectives:

- 1.) Setting a valid Aircraft Preliminary Design methodology
- 2.) Creating a tool that incorporates it and is able to optimize the design

The tool has to:

- autonomously find an optimal design,
- allow result traceability and
- keep its simplicity,

while allowing the user:

- to explore the design space,
- to understand the effect of the relationship between Aircraft Design parameters,
- to easily have access and change or adapt these relationships,
- to respond to questions regarding past experience, current designs, but also
- to look into the future, and be able to analyze innovative configurations.

*Simplicity* is required as the tool is to be used in early design stage, when resources are limited. *Result traceability* is required in order to make sensitive correlations and have the certainty that formal optimization delivers physically plausible results. **Isikveeren 2002** identifies the problem of lack of traceability in Aircraft Design programs and confirms its importance:

*...programs and algorithms producing the prediction during minimum goal formulation are not totally transparent, therefore the results are tacitly accepted or met with great skepticism such that more time is expended in justifying the result than the time it took to conduct the original analysis. This suspicion becomes even more pronounced whenever multi-parametric sensitivity studies take place. Owing to the quite complex interaction between multitudes of design variables, the physical relationships between disciplines become difficult to comprehend (Isikveeren 2002).*

The problem of old or unavailable data, which often occurs in Aircraft Design studies, is addressed by building new and actual statistical databases. Also, it is necessary to use the best, up-to-date estimation methods that take into account the *current trends*. For example, many of the equations for specific fuel consumption (SFC) estimation as a function of by-pass ratio (BPR) are valid only for BPR up to 8...10. The tendency is to build engines with higher BPR, as this favors the specific fuel consumption. Another example: the cabin comfort is a key feature that airlines seek to improve. Being able to make estimations on cabin parameters as early as in the Preliminary Sizing stage is becoming crucial. Also, it is required for the tool to analyze the design based on current objectives. Besides the classical Aircraft Design objectives: minimizing Direct Operating Costs (DOC), maximum take-off mass ( $m_{MTO}$ ) or fuel mass ( $m_F$ ), it is important to design an aircraft in a way that in the end it gets to be selected by the airline, against its competitors. It should be thus optimized also for all those Added Values that bring more revenue to an airline.

In the end the tool needs to represent a perfect combination between *human interaction* for understanding the design space and the effect of relating Aircraft Design equations *and non-human interaction* in automatically and rapidly finding the optimal design. The tool must be able to test *current questions* of Aircraft Design and be able to analyze *innovative configurations*, derived from conventional ones, thus allowing *technology assessment*.

These tool characteristics have not been found so far in a single simple tool, suitable for preliminary design and optimization (see Section 1.4). It is proven in this work that the created tool, called *OPerA – Optimization in Preliminary Aircraft Design*, fulfills all the objectives and can answer the question stated.

### *Question 2*

*Which values of the basic parameter combination in the initial design stage that includes aircraft cabin parameters leads to an optimum aircraft design?*

We build aircraft in order to respond to the demand of transportation. The environment, in which passengers are transported, is the aircraft cabin. The cabin represents the interface between the paying customer and the airline, but also an environment where passengers need to feel safe.

Here the objective is to understand the contribution of cabin parameters to the optimal design and to see how the aircraft design as a whole is influenced by cabin requirements.

### *Question 3*

*How can a process chain for cabin conversions be optimized, by using a scientific approach?*

Besides improving engineering design, to improve the organizational process chains and optimize work flows is equally important. In contrast to Aircraft Design, which occurs in the initial stage of aircraft development, the cabin suffers design changes throughout the *entire aircraft life*. Performing changes to existing (hence, certified) designs, may only occur if capability of performing and certifying the design is shown to the aeronautical authorities. It is thus of great importance to achieve organizational efficiency, that guarantees a flawless design. Due to this reason, it was decided that later stage Cabin Design tasks could also be covered and Question 3 could also be asked under the title of the work. The objective is to assist Design Organizations in the process of demonstrating design and certification capability by proposing scientific solutions for process chains optimizations.

If the first two Aircraft Design questions remain in the area of academic (though practical) study, the last question shifts towards practical industry challenges.



## 1.4 Previous Research

### 1.4.1 Software Tools for Aircraft Design

Usually, the earlier the design stage the simpler the tools. The reason is that, at the beginning of each project, resources are limited, while a large number of concepts need to be analyzed. During Preliminary Sizing, when only requirements are known, empirical, semi-empirical or statistical models are the only ones available. One method may be better than the other if it uses more up-to-date statistics. However, such empirical or statistical models are not always reliable.

More advanced tools may be efficiently adopted in the beginning of the design, for satisfying the necessity of early-stage-accuracy (of which was spoken in the Background section). This point of view is sustained also by **Amadori 2008** in his dissertation “On Aircraft Conceptual Design”.

Yet, most of the existing tools for Aircraft Design are based on classic approaches and lack connection with more advanced tools. In view of all the topics addressed by this work, it was concluded that existing Aircraft Design programs are not enough to provide a satisfactory answer to the research questions and objectives of this work. Below, a brief review of the past and current Aircraft Design tools, together with a critical assessment regarding their possible use for finding the answers to the stated research questions, is presented.

#### Software Tools based on Aircraft Design Books

Traditionally, Aircraft Design authors ended up by building software tools based on their Aircraft Design methodology and commercialized them:

- |               |   |
|---------------|---|
| Jan Roskam    | created the software tool <b>AAA: Program <u>A</u>dvanced <u>A</u>ircraft <u>A</u>nalysis</b> based on his book <i>Airplane Design</i> ( <b>Roskam 1989b</b> ).   |
| Daniel Raymer | developed <b>RDS: Integrated Aircraft Design and Analysis</b> based on his book <i>Aircraft Design: A Conceptual Approach</i> ( <b>Raymer 1999</b> ).   |
| Dennis Howe   | included spreadsheet calculation instruments in his book called <i>Aircraft Design Synthesis and Analysis</i> ( <b>Howe 2000</b> ).   |
| Dieter Scholz | developed at Hamburg University of Applied Sciences, based on his <i>Aircraft Design Lecture Notes</i> , the modular spreadsheet-based tool for Preliminary Sizing and Conceptual Design called <b>PreSTo: <u>P</u>reliminary <u>S</u>izing <u>T</u>ool</b> ( <b>Scholz 1999</b> ). |

## Software Tools based on Dissertations

Other software tools are the result of work performed during doctoral studies:

**QCARD**      **Quick Conceptual Aircraft Research and Development** was developed in Matlab® by Askin T. Isikveeren for his dissertation *Quasi-analytical modeling and Optimization Techniques for Transport Aircraft Design* (Isikveeren 2002). This tool was designed to predict, visualize and assist in optimizing conceptual aircraft designs with emphasis placed on user interactivity.

**PIANO**      **Aircraft Design & Analysis Software** was developed after the doctoral studies of D. Simos on the same topic. It has been commercialized by Lissys Ltd. since 1990. It builds on a large aircraft database and can only analyze conventional configurations (Simos 2011).

### Other Software Tools,

are the result of cooperation between universities, research institutions or industry:

**ACSYNT**      **Aircraft Synthesis** started as an initiative of Ames Research Center to improve the Conceptual Design process. It is now Joint Sponsored Research Agreement by Ames Research Center, NASA, and Virginia Tech. It is a complex tool that “requires significant time and effort to use it effectively” (Isikveeren 2002)

**APD**      **Aircraft Preliminary Design** was developed by the company Pace GmbH, in Berlin; it contains a parametric model for Aircraft Conceptual Design.

**CAPDA**      **Computer Aided Preliminary Design of Aircraft** was developed at Technical University Berlin as a tool for the analysis and Conceptual Design of commercial aircraft (Schmid 2009).

**PRADO**      **Preliminary Aircraft Design and Optimization** program. It was developed for many years as a modular Aircraft Design tool at Technical University Braunschweig by Dr. Wolfgang Heinze. This tool has been used also at Hamburg University of Applied Sciences.

**FLOPS**      **Flight Optimization System** is a multidisciplinary tool (with 9 modules) for designing and evaluating advanced aircraft concepts (Lavelle 1994); it was developed by NASA.

## Software Tools for Aircraft Cabin Design

Such tools, of interest for research Question 3, are:

**FPCC**            **Future Project Cabin Configuration** and  
**FPPD**            **Future Project Parametric Design**, developed by Pace GmbH for a rapid aircraft cabin configuration and the fuselage contour of the aircraft (**Pace 1995**).

**Pacelab Cabin** developed also by Pace GmbH, that uses the Knowledge Based Engineering concept in order to generate interior cabin layouts from a predefined database of layouts and a predefined database of cabin items constraints (Pacelab Cabin it is the advanced version of the previous two programs, which are not commercialized anymore).

One important criteria, as stressed so far in the introductory section, and also one of the key words of this work, is the *optimization* capability of the tool – the mean to find optimal parameter combinations as early as in preliminary design stage. Most of the Aircraft Design tools, enumerated above, only make design calculations based on user input data, such as: AAA, RDS, PreSTo. The optimization needs to be performed by the user. Also more complex tools, like PRADO, need detailed user input information. PIANO is limited to its database of aircraft data, as well as APD. QCARD seems to be closer to the concept followed by this work, yet it seems to lack the attribute of results traceability. CAPDA was part of a research project that finished, and is currently unavailable for testing. ACSYNT deals with Conceptual Design of entire aircraft, yet without optimizing parameters beginning as early as with Preliminary Sizing. (A more detailed description of most of the tools enumerated above is offered by **Mechler 2002**).

Regarding the tools for Cabin Design, based on the experience accumulated during the research project CARISMA, it was concluded that the use of such tools can be useful only for marketing purposes, but cannot be successfully applied in the engineering work. In the view of this work, Cabin Design parameters should be integrated into the Aircraft Design tool, while cabin redesign tasks can only be optimized separately. There seems to be no tool or method that has ever been applied for optimizing process chains for cabin redesign activities. This work delivers the first results on this subject.

## The Concept of Software Platforms

More complex Aircraft Design programs such as ACSYNT, CAPDA, FLOPS or PRADO need consistent user input and do not offer independent optimization for initial design stage. Instead of using complex Aircraft Design tools, an alternative (that seems to be preferred in industry) is to use the *software platform* concept. This type of platforms permits users to connect own tools and calculations to the platform, hence allowing a multidisciplinary approach. Such software platforms are enumerated below:

**ModelCenter®** developed by Phoenix Integration, is able to create an integrated design model by wrapping applications such as legacy codes, spreadsheet, simulation software, FEA, and CAD tools, and automates data exchange among them (**Hongman 2004**).

**Isight®** developed by Simulia, Dassault Systems (**Simulia 2013, Dirks 1999**), is a similar tool that aims to automate the design exploration and optimization. It works, as well, as an open system for integrating design and simulation models.

**Optimus®** developed by Noesis Solutions, Belgium, is also a software platform, but is specialized on optimization. It contains state of the art algorithms from gradient based to evolutionary.

Nevertheless, all these software platforms need, too, consistent user input. The designer needs to find the best Aircraft Design equations himself. Also, the designer has the task to make sensible correlations and integrate them into the platform.

After reviewing existing tools and approaches, it can be concluded, that indeed, in view of this work, but also for the (free!) use by the scientific community, a tool is required that:

- is able to autonomously find optimal combinations of basic aircraft parameters, including cabin parameters, during initial design stage;
- allows results traceability and understanding of the effect of the relationship between Aircraft Design parameters;
- is simple and easy to upgrade and adapt;
- is able to assess conventional but also unconventional configurations;
- is able to integrate more advanced tools, but is also able to deliver results independently.

The tool developed to incorporate the theoretical findings of this work, and to perform design optimization at initial design stage is *OPerA – Optimization in Preliminary Aircraft Design*.

### **The Tool Suite OPerA is Part of**

OPerA is foreseen to be part of a tool suite that was developed at Hamburg University of Applied Sciences. The tool suite covers three Aircraft Design levels:

- 1.) *SAS – Simple Aircraft Sizing* – is the standard tool covering the basic aircraft Preliminary Sizing process, as described in Section 2.1. Starting from five requirements, the design matching chart is found and the main aircraft parameters are calculated. Here, design parameters (aspect ratio, maximum lift coefficients, ...) are the engineers choice. Any design iteration is performed manually, and thus it requires some basic Aircraft Design knowledge. Currently, there are two versions of this tool: *SAS - Jet*, for large jet aircraft and *SAS - Prop*, for large propeller driven aircraft, both covering CS 25 or FAR 25

requirements. *SAS - Prop*<sup>1</sup> represents the first extension of *SAS - Jet*. It includes additional aspects to adjust the sizing process to propeller-driven aircraft. *SAS - Automated Matching* is a version that helps the users to find the design point automatically, and perform basic optimization<sup>2</sup>.

- 2.) *OPerA – Optimization in Preliminary Aircraft Design* – goes beyond Preliminary Sizing towards Conceptual Design; it includes drag and mass estimations, derivation of main geometrical parameters, specific fuel consumption model, Direct Operating Costs and even Added Values. It contains its own *Optimization Module* that allows the user to find the best combination of design parameters leading to a good design. It keeps the attribute of a simple tool, while allowing a complete Aircraft Design analysis for conventional configurations, including innovative concepts (high BPR engines, winglets, braced wing, natural laminar flow) and cabin parameters.
- 3.) *PreSTo – Preliminary Sizing Tool* – is an under development, modular and manual tool for Preliminary Sizing and Conceptual Design. It will ultimately contain a module for each step of classical Aircraft Design:
  - Sizing (*PreSTo-Sizing*)
  - Cabin and Fuselage Layout (*PreSTo-Cabin*)
  - Wing Layout
  - Design for High Lift
  - Empennage Layout
  - Landing Gear Layout
  - Mass and CG Estimation
  - Drag Estimation
  - DOC Calculation
  - Results, Interfaces to other Tools, 3D Visualization (*PreSTo-Vis*)

For interest in the second part of this research is the module *PreSTo - Cabin*, which supports the sizing and the interactive step-by-step design of the cabin in some detail. Additional to *OPerA*, *PreSTo* provides a more user-interactive layout description, visible in 2D representations.

*PreSTo* alone only supports limited and manual optimization. It may be connected with high level aircraft analysis tools (CEASIOM and PrADO) for further analysis in domains such as Flight Dynamics or CFD. The tool was designed to be user-interactive, and the great number of modules can lead to a difficult utilization. *OPerA* was built after the opposite philosophy: there is no need of expert knowledge or much user interaction and it is able to independently deliver results and optimize them. Thus, *OPerA* represents a very good data provider for

---

<sup>1</sup> This tool was the result of my diploma thesis (Niță 2008); see also Scholz 2009

<sup>2</sup> This tool was the result of my investigations for *OPerA*

PreSTo: parameters are already optimized, and only a single run through all modules would be necessary to finalize the Conceptual Design of the aircraft.

Summing up, SAS allows a manual analysis of basic Preliminary Sizing parameters, while OPerA can function independently, as a Preliminary Sizing and Conceptual Design and Optimization tool, and is able to deliver optimized parameters for further user interactive changes in PreSTo.

## 1.4.2 Aircraft Design Optimization

In the previous section it was concluded that not many tools integrate optimization algorithms suitable for Aircraft Preliminary Design. However, optimization algorithms were employed in many design studies, both in preliminary and detailed design stage.

Usually, Aircraft Conceptual Design and Preliminary Sizing Optimization is suitable to non-gradient based (zero-order) or stochastic methods. This is because, during initial design stage, some parameters describing the configurations are discrete (e.g. number of engines, number of seats abreast). This leads to discontinuity and non-derivability of the objective functions, hence higher order methods (or deterministic methods) would be inapplicable.

Even though many authors use stochastic algorithms, depending on the optimization strategy and the type of objective function, some of them select also gradient-based algorithms. Daniel Raymer (**Raymer 2002**) compares in his doctoral thesis both deterministic and stochastic optimization methods, applicable in Aircraft Conceptual Design. He underlines that Aircraft Conceptual Design process can be improved by the proper application of optimization methods. (His main conclusion is that costs can be reduced with only minor changes in key design variables – statement which is proven also by the results of this work.) Another author, that used both deterministic and stochastic methods during his doctoral studies, is Askin Isikveeren<sup>1</sup> (**Isikveeren 2002**). The author used the selected methods with the aid of the Matlab Optimization Toolbox in his Matlab-based tool, QCARD (briefly discussed in the previous section).

In view of this work, which aims to optimize both discrete and continuous parameters, this section discusses rather those literature studies that use stochastic methods, suitable for objective functions containing also discrete parameters. It is here anticipated that especially those algorithms from the class of Evolutionary Algorithms (EA) are of interest for this work.

---

<sup>1</sup> Both **Raymer 2002** and **Isikveeren 2002** did not optimize discrete parameters, which made this approach possible

Evolutionary Algorithms (EA) were lately extensively used in Aircraft Design. These are the most widely used representatives of population-based, gradient-free, stochastic optimization methods (**Giannakoglou 2008a**). Their main disadvantage, compared to gradient methods, is the higher computational expense, as they require more function evaluations than gradient-based methods (**Rai 2008, Giannakoglou 2008a**). However, they are able to find global optima of multi-modal functions (not guaranteed) and can address design spaces with disjoint feasible regions. Also they can use parallel computing resources (**Rai 2008**).

Research has been performed also towards hybridization of EAs and gradient-based methods (**Giannakoglou 2008a, Giannakoglou 2008b, Giannakoglou 2008a**) for the purpose of increasing their efficiency and effectiveness, “a good reason for considering them as complementary rather than rival methods!”, states **Giannakoglou 2008a**.

EAs are addressed in more detail in Section 5. Here it is shown that many Aircraft Design studies successfully used them. As such, the effectiveness of Evolutionary Algorithms in aircraft Conceptual and Preliminary Design was shown in many studies and dissertations, some of which are:

- Isikveeren A. in his dissertation: *Quasi-analytical modeling and Optimization Techniques for Transport Aircraft Design* (**Isikveeren 2002**), where he uses Genetic Algorithms (GA) – one of the most used evolutionary approach, for conceptual design optimization.
- Crispin Y. in his work: *Aircraft Conceptual Optimization Using Simulated Evolution* (**Crispin 1994**), proved efficiency of Genetic Algorithms (GA) in finding feasible Aircraft Conceptual Designs.
- Ali N. and Behdinan K. in their work: *Conceptual Aircraft Design – A Genetic Search and Optimization Approach*, (**Ali 2002**) applied GAs for finding optimal parameter combinations for medium-sized transport aircraft. They underline the importance of using Evolutionary Algorithms for cost savings in the early design stage.
- Crossley A. applied Genetic Algorithms in his paper: *Design of Helicopters via Genetic Algorithm* (**Crossley 1996**) on helicopter conceptual design, and proved their effectiveness.
- Cantelmi F. used a stochastic method (Simulated Annealing) for the preliminary design of a Blended Wing Body Aircraft (BWB) and proved that stochastic optimization techniques provide a robust, systematic means of performing global searches in

design spaces with large discontinuities and noise (**Cantelimi 1998**).

Kroo I.

in his AIAA Paper: *Multidisciplinary Optimization Methods for Aircraft Preliminary Design* (**Kroo 1994**) addresses the problem of system decomposition by using compatibility constraints and collaborative optimization. For the second task, he uses a genetic algorithm to find a decomposition that minimizes the estimated computational time of a gradient-based optimization of the resulting decomposed system.

Metzger R.

applied Evolutionary Algorithms in his doctoral thesis on fuselage cross-section optimization for preliminary design (**Metzger 2008**). In contrast to this work, he only focused on fuselage. With the paper (**Niță 2010**) I prove that fuselage design can only be part of an overall Aircraft Design Optimization. Metzger also needed to set up the calculation of main aircraft parameters in order to estimate the impact of the fuselage cross-section over the entire aircraft.

Evolutionary Algorithms (EA) have been successfully used also in other aeronautical engineering areas:

*Wing design*

Obayashi S. (**Obayashi 1997a**, **Obayashi 1998**) used Evolutionary Algorithms for multi-objective optimization in order to find Pareto fronts for transonic and supersonic wings; other applications were performed by: **Anderson 1996**, **Oyama 2002**, **Gonzales 2004a**, **Takahashi 1997**, **Lee 2008**;

*Single and multi-element airfoil design,*

where many authors have shown that EAs are suitable also for aerodynamic shape optimization: **Obayashi 1997a**, **Périaux 2002**, **Obayashi 1997b**, **Lee 2007**, **Obayashi 1998**, **Marco 1989**, **Quagliarella 1999**, **Jones 1998**, **De Falco 1995**, **Sefrioui 1996**, **Srinivas 2008**, **Gonzales 2004b**, **Whitney 2003**;

*Intake / Nozzle design,*

where authors used such algorithms for generating optimal geometries (**Knight 2001**, **Sefrioui 2000**).



## 1.5 Structure of the Work

After the introductory section that discusses the motivation and background of the topic and title selection, formulates the research questions and objectives, and briefly presents the state of the current research and available tools, the following sections are part of the work:

- Section 2 Methodology for Aircraft Preliminary Sizing and Conceptual Design** presents the applied Aircraft Design methodology, underlines own contributions, provides current case studies and identifies key parameters for optimization.
- Section 3 Methodology for Cabin and Fuselage Preliminary Sizing and Conceptual Design** presents the Preliminary Design methodology used to describe cabin parameters, underlines own contributions and identifies key parameters for optimization.
- Section 4 Methodology Calibration and Testing** shows how the tool *OPerA – Optimization in Preliminary Aircraft Design* that incorporates the methodology, was calibrated and shows the results of testing the way the compendium of equations works together on manual redesign cases. It also talks about the problem of solving iterations in Aircraft Design, about the stability of the tool, its design space as well as its particularities and limitations.
- Section 5 Brief Theoretical Background on Optimization and Algorithms Selection** discusses categories and classes of optimization algorithms and eventually selects the class and the algorithms which are suitable for the optimization problem.
- Section 6 Implementation of Selected Algorithms in OPerA** briefly presents the selected optimization algorithms for single and multiple parameter variations and the way they were implemented within the OPerA tool. Comparative results are given that demonstrate high algorithm efficiency, equal to the capabilities of the commercial tool Optimus®.
- Section 7 Description of OPerA: Tool for Preliminary Design and Optimization of Aircraft and Cabin Parameters** describes the tool *OPerA – Optimization in Preliminary Aircraft Design*, developed to encompass the new methodology, as well as its optimization module and its connection with the software platform Optimus®.

- Section 8**     **Objective Functions** talks about the classical objectives that are used in Aircraft Design and dedicates a section to Added Values selected via expert questioning in order to build a composed objective function that accounts for additional revenue possibilities for an airline.
- Section 9**     **Optimization Results** talks about parameters and parameter combinations and presents the results obtained based on a reference medium range commercial aircraft. Different study cases, with both aircraft and cabin parameter variations, are selected in order to demonstrate tool capabilities, but also to extract meaningful Aircraft Design statements and to perform a technology assessment for the referred aircraft category.
- Section 10**    **Cabin Design and Conversion in Industry** continues the research on impact of cabin design also on the aircraft life and illustrates the importance of cabin conversions, the way they are performed in industry and explains the certification implications of this type of engineering design work.
- Section 11**    **Optimization of the Process Chain for Cabin Conversions** proposes a scientific approach to process chain optimization, on the example of a standard process chain for Cabin Conversion.
- Section 12**    **Conclusions and Summary of Contributions** underlines achievements and own contributions and concludes upon the results.
- Section 13**    **Outlook** underlines current and further possible utilizations and developments of OPerA.

The sections briefly presented above, compose the body of the work so as to cover the answers to the research questions (see also Figure 1.2):

- |                        |  |                   |
|------------------------|--|-------------------|
| Sections 2, 3, 4 and 5 | set up a methodology and conclude upon appropriate optimization approach;  | Questions 1 and 2 |
| Sections 6 and 7       | create and finalize the tool OPerA – <u>O</u> ptimization in <u>P</u> reliminary <u>A</u> ircraft Design based on this methodology and on the results produced with it (in Section 9); |                   |
| Section 8 and 9        | set objective functions, produce and assess results based on a reference aircraft;   | Question 3        |
| Sections 10 and 11     | complete the research with the missing piece of information required during aircraft <i>re</i> -design, later during aircraft life;  |                   |
| Sections 12 and 13     | discuss and conclude upon the accomplishments of the work.   |                   |

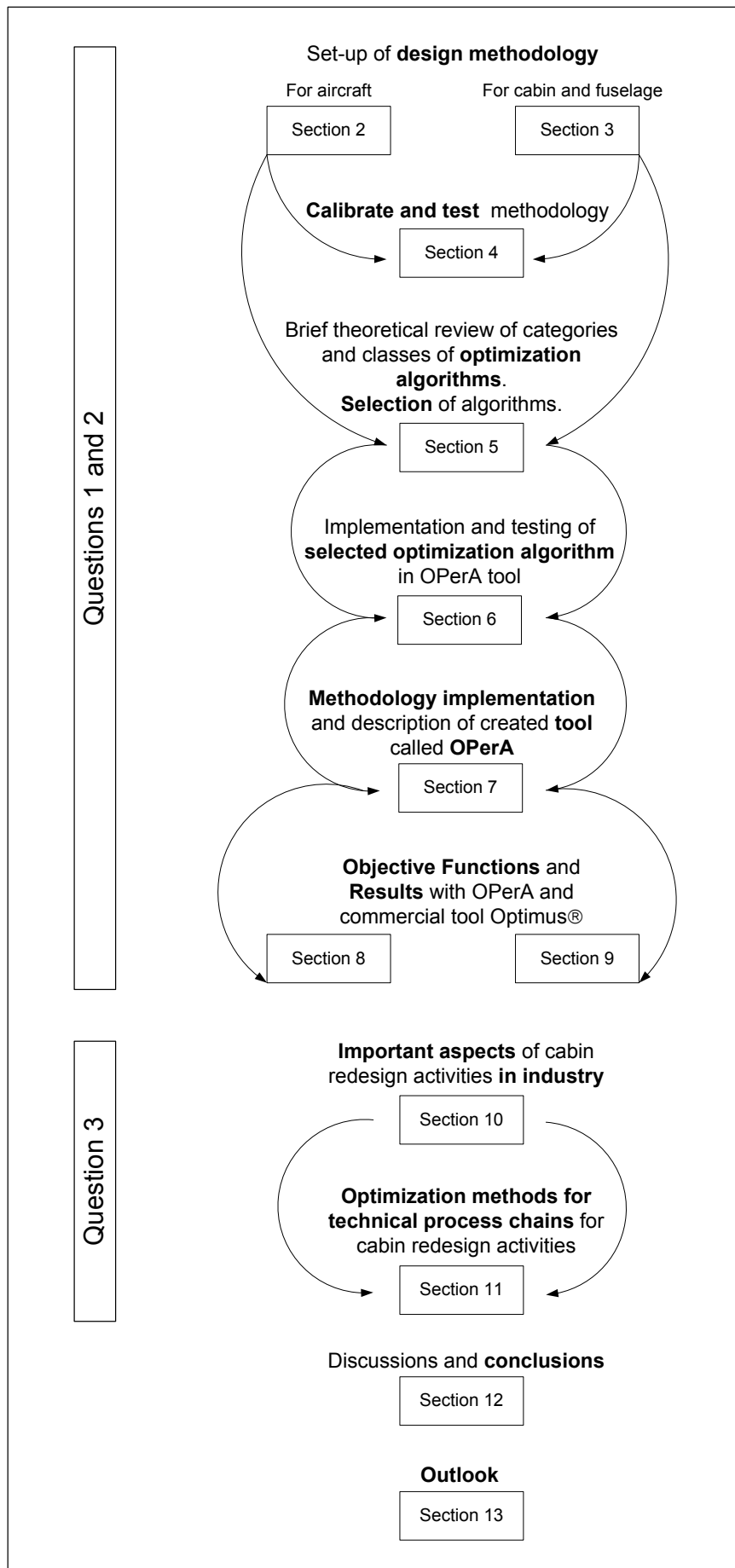

Fig. 1.2

Structure of the work

## 2 Methodology for Aircraft Preliminary Sizing and Conceptual Design

The classical Aircraft Design processes have been briefly presented in the introductory section. Here a methodology for aircraft Preliminary Sizing, based on **Loftin 1980** and **Scholz 1999**, is described and own contributions in aircraft Conceptual Design methodology are presented.

### 2.1 Sizing from Requirements and Statistics

Parameters in Aircraft Design can be divided into *requirements* and *design parameters* (**Scholz 1999**). Basic requirements are payload,  $m_{PL}$  and range,  $R$ . An initial requirement that can later be the subject of economic optimization is the *Cruise Mach number*,  $M_{CR}$ . Regarding *Take-off* and *Landing* mission segments, the requirements rise from airport characteristics and certification requirements, namely landing and take-off field length,  $S_{LFL}$ ,  $S_{TOFL}$ . Requirements for *Second Segment* and *Missed Approach* are the respective climb gradients,  $\gamma$ , for each of the two segments. These are set by certification specifications.

These requirements represent the only known parameters at the beginning of the sizing process. At the end of this process, enough design parameters are found to start Conceptual Design of the aircraft, which provides geometry and main aircraft characteristics. The result of this preliminary design stage is enough to justify and freeze a very limited number of concepts that are further studied in the detailed design phase, with computational simulations and wind tunnel testing (see Figure 1.1 in Section 1).

*Instruments* used in Aircraft Design in the pursuit of calculating additional design parameters are (**Scholz 1999**):

- Statistical data,
- Experimental data,
- Inverse methods,
- Formal optimization,
- ...or a combination of all these.

The next sections develop on the lecture notes of Prof. Dr.-Ing. Dieter Scholz (**Scholz 1999**). They are the result of accumulated experience during many years of teaching Aircraft Design at Hamburg University of Applied Sciences. Including a more detailed Aircraft Design paradigm was found adequate, due to the intended wider use of this work (e.g. at the partner University in Bucharest).

## 2.1.1 Landing Distance and Approach Speed

The landing requirements can be expressed in terms of approach speed,  $V_{APP}$  or landing field length,  $S_{LFL}$ . The relation between the two can be statistically expressed, through a factor  $k_{APP}$ :

$$V_{APP} = k_{APP} \cdot \sqrt{S_{LFL}} \quad . \quad (2.1)$$

This factor assumes similar braking characteristics of aircraft (in one category). **Loftin 1980** calculated in 1980 a value of  $k_{APP} = 1.70 \sqrt{\text{m/s}^2}$ . Based on updated statistics, for the generation of A320 aircraft, the value of  $k_{APP} = 1.79 \sqrt{\text{m/s}^2}$  is valid. The higher value suggests that braking characteristics of aircraft have improved in time.

From the wing loading at maximum landing mass and relation (2.1), Equation (2.2) can be extracted, and thus a relation between  $k_{APP}$  and a factor for landing, called  $k_L$  [ $\text{kg/m}^3$ ] can be set:

$$\begin{aligned} m_{ML} / S_W &= k_L \cdot \sigma \cdot C_{L,max,L} \cdot S_{LFL} \\ k_L &= 0,03694 k_{APP}^2 \end{aligned} \quad . \quad (2.2)$$

Following  $k_{APP}$  factors,  $k_L$  factors have also changed in time. A trade-off seems to have been performed over time between braking characteristics and increase in lift coefficient.

Wing loading *must not be exceeded*, in order for the design to meet the landing requirements. In order to express Equation (2.2) in terms of wing loading relative to maximum take-off weight, the ratio maximum landing mass,  $m_L$ , to maximum take-off mass,  $m_{MTO}$  can be introduced:

$$m_{MTO} / S_W \leq \frac{k_L \cdot \sigma \cdot C_{L,max,L} \cdot S_{LFL}}{m_{ML} / m_{MTO}} \quad . \quad (2.3)$$

**Loftin 1980** and **Roskam 1989a** give statistics for the ratio  $m_{ML} / m_{MTO}$ . In practice it is quite easy to perform such a statistic, as these masses are available in books like Jane's (**Jackson 2007**). Short range aircraft have on average  $m_{ML} / m_{MTO} = 0.94$ , medium range aircraft have on average  $m_{ML} / m_{MTO} = 0.84$  and long range aircraft need a smaller value, as they fly longer, and require more fuel:  $m_{ML} / m_{MTO} = 0.73$ .

## 2.1.2 Take-off Distance

Based on a simplified equation for take-off ground roll in conjunction with a statistical parameter,  $k_{TO}$ , the following take-off requirement can be expressed:

$$\frac{T_{TO} / (m_{MTO} \cdot g)}{m_{MTO} / S_W} \geq \frac{k_{TO}}{s_{TOFL} \cdot \sigma \cdot C_{L,max,TO}} \quad (2.4)$$

The thrust-to-weight ratio over wing loading must respect Equation (2.4) if take-off requirements are to be met.

**Loftin 1980** gives the value of 2.34 m<sup>3</sup>/kg for the factor  $k_{TO}$ , for jet aircraft. An up-to-date statistic shows an increase of this factor in time. For the generation of A320 aircraft the value of 2.43 m<sup>3</sup>/kg is valid. This should and does correspond to an increase of  $C_{L,max,TO}$  values in time.

In Preliminary Sizing, usually, the user sets the value of the maximum lift coefficient in landing configuration, and the coefficient for take-off is calculated as a percentage of it. **Raymer 1999** gives a value of 80 %, while the A320-200 aircraft has 90 %.

## 2.1.3 Second Segment Climb and Missed Approach Climb Gradient

From the Flight Mechanics equation and from the requirement to climb also with a failed engine, the following condition results for the Second Segment Climb:

$$\frac{T_{TO}}{m_{MTO} \cdot g} \geq \left( \frac{n_E}{n_E - 1} \right) \cdot \left( \frac{1}{E_{TO}} + \sin \gamma \right) \quad (2.5)$$

where  $n_E$  is the number of engines,  $E$  is the lift-to-drag ratio in take-off configuration and  $\gamma$  is the climb gradient.

The lift-to-drag ratio,  $E_{TO}$ , for a configuration with extended landing gear and extended flaps, can be estimated from aspect ratio,  $A$ , and an empirical value for the Oswald factor,  $e$ , accounting for extended flaps and slats.  $e = 0.7$ , is a good value (**Scholz 1999**). Additionally the following assumptions can be used (**Loftin 1980**):

$$\begin{aligned} \Delta C_{D,0,flap} &= 0.05 C_L - 0.055 && \text{for } C_L \geq 1.1 \\ \Delta C_{D,0,slat} &&& \text{negligible} \\ \Delta C_{D,0,gear} &&& 0.015 \text{ in case landing gear is extended} \end{aligned}$$

Similarly, for Missed Approach the following requirement needs to be fulfilled (climb gradients are given in the certification specifications for both Missed Approach and Second Segment):

$$\frac{T_{TO}}{m_{MTO} \cdot g} \geq \left( \frac{n_E}{n_E - 1} \right) \cdot \left( \frac{1}{E_L} + \sin \gamma \right) \cdot \frac{m_{ML}}{m_{MTO}} \quad . \quad (2.6)$$

#### 2.1.4 Cruise Mach Number

Expressed in terms of cruise thrust relative to take-off thrust, the following equation (derived from Thrust equals Drag,  $T = D$ ) is valid:

$$\frac{T_{TO}}{m_{MTO} \cdot g} = \frac{1}{(T_{CR} / T_0) \cdot E} \quad . \quad (2.7)$$

**Scholz 1999** gives a good approximation, compared to other sources, for  $T_{CR} / T_{TO}$ :

$$T_{CR} / T_{TO} = (0.0013BPR - 0.0397) \sqrt[3]{h_{CR}} - 0.0248BPR + 0.7125 \quad . \quad (2.8)$$

From Lift and Weight ( $L = W$ ), the wing loading can be calculated:

$$\frac{m_{MTO}}{S_W} = \frac{C_L \cdot M^2}{g} \cdot \frac{\gamma}{2} \cdot p(h) \quad , \quad (2.9)$$

where  $\gamma$  is the ratio of specific heats and  $p(h)$  is the pressure as a function of altitude.

The lift coefficient in Equation (2.9) is the cruise lift coefficient, that often is chosen as the lift coefficient for minimum drag or for maximum lift-to-drag ratio,  $C_{L,md}$ .

Cruise Mach number is a fix requirement, thus the speed  $V$ , at cruise altitude is constant. In order to reach  $C_{L,md}$ , the aircraft should fly at minimum drag speed,  $V_{md}$ . A ratio  $V / V_{md}$  can be chosen in order to fix  $C_{L,md}$ . For  $V / V_{md} = 1$ , the flight is performed at maximum glide ratio ratio,  $E_{max}$ . From Flight Mechanics, a flight that produces the highest range for a jet aircraft – and thus meets the range requirement most easily – requires  $V / V_{md} = 1.316$ . The lift coefficient and the lift-to-drag ratio in cruise can be extracted from:

$$C_L / C_{L,md} = 1 / (V / V_{md})^2 \quad . \quad (2.10)$$

$$E = E_{max} \cdot \frac{2}{\left(\frac{C_l}{C_{l,md}}\right) + \left(\frac{C_l}{C_{l,md}}\right)} \quad (2.11)$$

Maximum lift-to-drag ratio can be estimated with one of the following equations:

$$E_{max} = \frac{1}{2} \sqrt{\frac{\pi \cdot A \cdot e}{C_{D,0}}} \quad (2.12)$$

or

$$E_{max} = k_E \sqrt{\frac{A}{S_{wet} / S_W}} \quad (2.13)$$

$$k_E = \frac{1}{2} \sqrt{\frac{\pi \cdot e}{c_f}}$$

If Oswald factor,  $e$ , relative wetted area,  $S_{wet} / S_W$ , and the equivalent friction coefficient,  $\overline{c_f}$  are taken from statistics, Equation (2.13) is suitable for a fast estimation. This is the usual practice in aircraft Preliminary Sizing. If a step forward is taken, towards Conceptual Design, Equation (2.12) can be used. In OPerA both alternatives are offered (see tool description in Section 7). OPerA contains complete estimations of wetted areas and zero-lift drag and also an own calculation method for Oswald factor (see Sections 2.2.1 and 2.2.2.).

Suitable values for the above terms are (based on **Raymer 1999**, **Scholz 1999**, and experience from aircraft redesign cases with OPerA):

$$e = 0.8$$

$$c_f = 0.003$$

$$S_{wet} / S_W = 6.0 \dots 6.3$$

## 2.1.5 Combining Requirements in a Matching Chart

All five requirements were expressed in terms of thrust-to-weight ratio and wing loading. This allows a two dimensional representation of all requirements in a single chart. *This is the core and basic optimization as traditionally applied for hand calculations* (see Figure 2.1 and Table 2.1).

The result of the simultaneous representation of the requirements in the matching chart is the *design point* that fulfills these conditions in this order:

1<sup>st</sup>. Preference: Low thrust-to-weight ratio,

2<sup>nd</sup>. Preference: High (suitable) wing loading.



**Table 2.1** Requirements, inputs and outputs in Preliminary Sizing

Requirement	Input	Output
Landing distance	$C_{Lmax,L}, S_{LFL}$	A maximum value of the wing loading, $m_{MTO}/S_w$
Take-off distance	$C_{Lmax,TO}, S_{TOFL}$	A minimum value of the thrust-to-weight ratio as a function of wing loading, $T / (m \cdot g) = f(m / S)$
Climb rate 2 <sup>nd</sup> Segment	$L/D$	Minimum values for the thrust-to-weight ratio $T / (m \cdot g)$
Climb rate Missed Approach	$L/D$	Minimum values for the thrust-to-weight ratio $T / (m \cdot g)$
Cruise	$M, C_L, BPR,$ <i>atmosphere</i>	A minimum value of the thrust-to-weight ratio as a function of wing loading, $T / (m \cdot g) = f(m / S)$

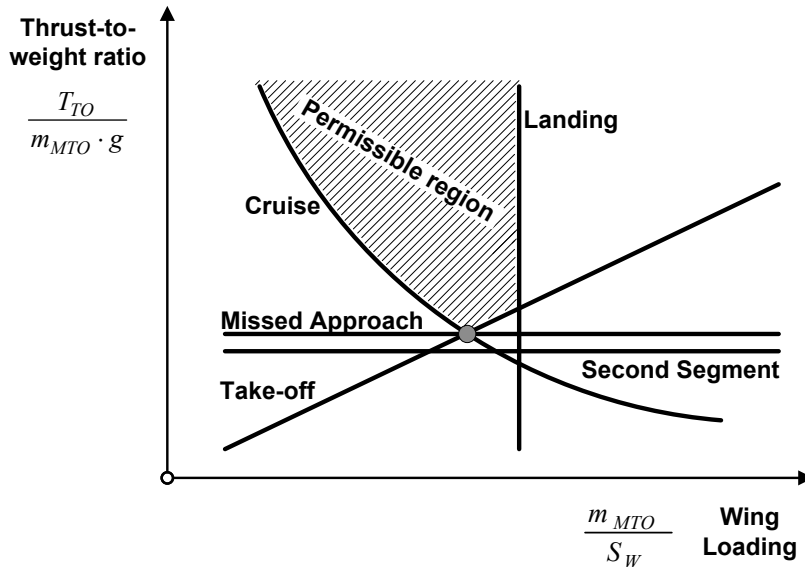
**Fig. 2.1** An example of a matching chart. The grey point is the design point.

In OPerA, the matching chart represents what is called *inner optimization* in this work, which is incorporated within the *formal optimization* process, performed via the algorithms in the Optimization Module of the tool. Traditionally the design point is manually read from the matching chart. In OPerA the design point results automatically. An algorithm was programmed in VBA to find the design point when pressing a command button. The philosophy that has driven this idea, is that the cruise line and the landing line should always be part of the design point. Hence: first, the intersection point between (Landing and Take-off) or (Landing and Missed Approach) or (Landing and Second Segment) having the highest thrust-to-weight ratio is found. Second, the cruise line is forced to be part of this intersection point by correspondingly adjusting the  $V / V_{md}$  ratio. This intersection represents the design point. Below this point, the design would not fulfill given requirements.

The chart is therefore, automatically optimized, or in other words, the inner optimization is performed automatically with every change of input parameters (i.e. with every design iteration). This automated, inner, chart-based optimization is incorporated into formal optimization: each parameter combination tested within the formal optimization starts from an optimized design point, resulted from the inner optimization.

This automatism of matching the chart via the  $V / V_{md}$  ratio was incorporated also in the tool SAS – Simple Aircraft Sizing. The resulting version got the name SAS – Automated Matching.

With the design point, given by the pair  $(m_{MTO} / S_W; T_{TO} / m_{MTO} / g)$ , further calculations are possible: relative operating empty mass or relative useful load.

## 2.1.6 Estimating Relative Operating Empty Mass

In order to estimate the maximum take-off mass, in Preliminary Sizing the approach is to use experience-based estimations for relative fuel mass and relative operating empty mass:

$$m_{MTO} = \frac{m_{PL}}{1 - \frac{m_F}{m_{MTO}} - \frac{m_{OE}}{m_{MTO}}} \quad (2.14)$$

**Loftin 1980** gives the following approximation for the relative operating empty mass:

$$m_{OE} / m_{MTO} = 0.23 + 1.04 \cdot \left( T_{TO} / m_{MTO} g \right) \quad (2.15)$$

This equation is in agreement with statistical data and proves to be a good choice (**Scholz 1999**).

**Markwardt 1998** follows a different approach:

$$m_{OE} / m_{MTO} = 0.591 \cdot \left( R[\text{km}] / 1000 \right)^{-0.113} \cdot \left( m_{MTO}[\text{kg}] / 1000 \right)^{0.0572} \cdot n_E^{-0.206} \quad (2.16)$$

His equation has to be used iteratively:

1. select a starting value  $m_{OE} / m_{MTO} = 0.5$
2. insert  $m_{OE} / m_{MTO}$  into Equation (2.14) and obtain  $m_{MTO}$  (with  $m_F / m_{MTO}$  from Section 2.1.7)
3. calculate a new value for  $m_{OE} / m_{MTO} /$  from Equation (2.16)
4. go back to step 2 and repeat until convergence.

In OPerA, which goes beyond Preliminary Sizing, towards Conceptual Design, enough parameters are available for a direct component-based mass derivation. In this case, the operating empty mass,  $m_{OE}$ , is calculated as a sum of aircraft components (from **Torenbeek 1986, Herrmann 2010, AFPO 2006**); Equation (2.15) is also included as user alternative.

## 2.1.7 Estimating Relative Fuel Mass

The fuel mass consumed during the flight can be calculated from mission fuel fractions, deriving from the flight phases:

$$\frac{m_F}{m_{MTO}} = 1 - M_{ff} \quad (2.17)$$

$M_{ff}$  is the product of mission segment mass fractions, given by  $m_{i+1} / m_i$ , where  $m_i$  is the mass at the beginning of a flight phase ( $i = \text{TO, CLB, CR, ...}$ ) and  $m_{i+1}$  is the mass at the start of the next flight phase (Scholz 1999). A typical flight mission and its phases are shown in Figure 2.2.

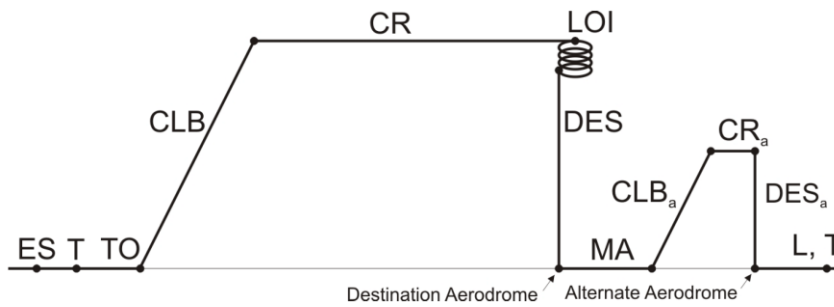

Fig. 2.2 Typical flight mission (Scholz 1999)

The mission segment mass fraction for the cruise phase can be expressed in terms of the Breguet factor:

$$\frac{m_{LOI}}{m_{CR}} = e^{-\frac{S_{CR}}{B_S}} \quad (2.18)$$

where  $S_{CR}$  is the distance covered during cruise, and the Breguet factor is given by:

$$B_S = \frac{E \cdot V}{TSFC \cdot g} \quad (2.19)$$

with TSCF = Thrust Specific Fuel Consumption.

Certification specifications have additional requirements with respect to fuel reserves. Mission fractions need to be calculated for fuel reserves in a similar way and included into the calculation for aircraft Preliminary Sizing.

For the rest of the mission segment mass fractions it is rather difficult to make estimations. Roskam 1989a delivers some values, yet it was found difficult to understand their logic. For taxi segment enough statistical data was found to estimate a fuel fraction of 0.997. For the rest

of the fuel fractions an equal value of 0.993 was set, based on a redesign study case performed with OPerA, for which accurate data was available.

### 2.1.8 Calculating Basic Aircraft Parameters

With the values of relative operating empty mass and relative fuel mass discussed above, the maximum take-off mass can be found with Equation (2.14). If a direct, component-based approach is adopted for  $m_{OE}$  calculation, then the maximum take-off mass will represent the sum between payload mass,  $m_{PL}$ , fuel mass,  $m_F$ , and operating empty mass,  $m_{OE}$ .

With known  $m_{MTO}$ , take-off thrust and wing area can be calculated from the design point given by  $T_{TO}/m_{MTO} \cdot g$  and  $m_{MTO}/S_W$  :

$$T_{TO} = m_{MTO} \cdot g \cdot \left( T_{TO}/m_{MTO} \cdot g \right) . \quad (2.20)$$

$$S_W = m_{MTO} / \left( m_{MTO}/S_W \right) . \quad (2.21)$$

Additional parameters that result implicitly are maximum landing mass,  $m_{ML}$ , from landing mass ratio; fuel mass,  $m_F$  from relative fuel mass; zero fuel mass,  $m_{MZF}$ . A check needs to be performed, whether landing mass is high enough in order to ensure enough fuel reserves.

Starting only from design requirements, essential parameters were described. The next step in setting a complete and practical design optimization procedure is basic Conceptual Design. The following section consists of own contributions brought to the preliminary design strategy, briefly described so far.

## 2.2 Refinement of the Aircraft Sizing and Conceptual Design Methodology

### 2.2.1 Estimating the Oswald Factor for Conventional Configurations

In the basic Preliminary Sizing method, the Oswald factor is estimated from statistics. For a better accuracy, and for including the effects of aspect ratio,  $A$ , sweep angle,  $\varphi$ , and taper ratio,  $\lambda$ , on aerodynamics (i.e. Oswald factor), a proper estimation method for the Oswald factor is necessary.

Several approaches were identified from an exhaustive literature study and the accuracy and logic of these approaches were assessed. The deep understanding of the theoretical background and of the relations between parameters that yielded from this literature study, helped creating the grounds for an own, simple but logical approach, in concordance to the theory.

Further on, this section presents a brief theoretical background, the summary of the literature study, the proposed method for conventional configurations and the proposed method for non-planar configurations. For more details, refer to the author's paper published on this topic at the German Aerospace Congress (Niță 2012).

#### Brief Theoretical Background

The lift-dependent drag term has two components (Kroo 2006, Obert 2009):

- an *inviscid* part, which is caused by induced velocities from the wake (also called vortex drag); it includes the effect of a zero-lift term due to wing twist;
- a *viscous* part, which is caused by increases in skin friction and pressure drag due to changes in angle of attack. It hence depends on wing parameters (such as leading edge geometry, camber, thickness ratio, sweep) and on the interference of other aircraft components with the wing flow (pylon interference, fuselage upsweep, tail induced drag, engine power effects, etc.).

Equation (2.22) is the common way to express the induced drag coefficient. The Oswald factor,  $e$ , accounts for any deviation from an ideal elliptical lift distribution, for which this factor is 1:

$$C_D = C_{D,0} + C_{D,i} = C_{D,0} + \frac{C_L^2}{\pi A e} = C_{D,0} + \frac{C_L^2}{\pi A} (1 + \delta) \quad . \quad (2.22)$$

After looking at different authors, it was found suitable to express the lift-dependent drag (as a parabolic variation with  $C_L^2$ ) in the following form:

$$C_{D,i} = \left( \frac{Q}{\pi A} + P \right) \cdot C_L^2 \quad . \quad (2.23)$$

From Equation (2.23) the Oswald factor,  $e$  (for the whole aircraft) can be extracted in the form:

$$e = \frac{1}{Q + P\pi A} \quad . \quad (2.24)$$

The term  $Q$  covers the *inviscid* part of the induced drag coefficient.  $e_{inviscid} = 1 / Q$  is just the inviscid part of the Oswald factor without consideration of other effects on the aircraft. The term  $P$  is used to express the *viscous* part of the induced drag coefficient (in addition to the viscous drag in the zero lift drag coefficient).

### Summary of Literature Study

Most of the authors give expressions of the Oswald factor for Aircraft Design as in form (2.24), proposed before. Especially these authors for this approach should be named: **Kroo 2006**, **Stinton 2001**, **Grosu 1965** and **Obert 2009**. Other authors express the Oswald factor in terms of  $\delta$ :

$$C_{D,i} = \left( \frac{Q}{\pi A} + P \right) C_L^2 = \frac{C_L^2}{\pi A} (1 + \delta) = \left( \frac{1}{\pi A} + \frac{\delta}{\pi A} \right) C_L^2 \quad .$$

One way to interpret this is with  $Q = 1$  and  $P = \delta / \pi A$ . However, if the respective author is just considering the theoretical induced drag, then  $Q = 1 + \delta$  and  $P = 0$ . So,  $e_{theo} = 1 / (1 + \delta)$ .

In other cases authors use empirical data from wind tunnel tests or make use of mathematical regressions to match an equation to a virtual design space. This type of equations is valid only for a specific domain, and in some of the cases, it is difficult to read the diagrams which are given.

Twist influence is by most of the authors neglected, or only partially covered. **Hörner 1951**, for instance, only covers the negative effect, while **Dubs 1975** and **Kroo 2006** give limited data.

Tables 2.2 and 2.3 present an overview of the literature study. More details and conclusions about each investigated author and method can be found in **Niță 2012**.

**Table 2.2** Summary of literature study (1 of 2 Tables)

Author / Ref.	Scope	Q	P	Remarks
<b>Obert 2009</b>	whole aircraft	$Q = 1.05$	$P = 0.007$	Constant values based on experimental data.
<b>Kroo 2006</b>	whole aircraft	$Q = 1/(u \cdot s)$	$P = K \cdot C_{D,0}$	The product ( $u \cdot s$ ) represents the inviscid part of the induced drag. $u = e_{theo}$ is the theoretical Oswald factor. $s$ accounts for the fuselage interference. The viscous part of the induced drag is proportional to the (viscous) zero lift drag coefficient. $K = 0.38$ .
<b>Stinton 2001</b>	whole aircraft	$Q = K$	$P = m$	Values are indicated for $K$ and $m\pi A$ .
<b>Schaufele 2000</b>	whole aircraft	$Q = 1.03$	$P = K \cdot C_{D,0}$	Data given in the form of a diagram. The viscous part of the induced drag is proportional to the (viscous) zero lift drag coefficient. $K = 0.38$ .
<b>Hörner 1951</b>	inviscid, theoretical	$Q = 1 + A \cdot f(\lambda)$	$P = 0$	$\delta / A = f(\lambda)$ given in the form of a diagram.
<b>McCormick 1995</b>	inviscid, theoretical	$Q = 1 + \delta$	$P = 0$	$\delta = f(\lambda, A)$ given in the form of a diagram.
<b>Dubs 1975</b>	inviscid, theoretical	$Q = 1 + \delta$	$P = 0$	$\delta = f(\lambda, A/\eta)$ given in the form of a diagram.
<b>ESDU 1996</b>	inviscid, theoretical	$Q = 1 + \delta$	$P = 0$	Data given in the form of diagrams. Requires time consuming manual process. The result represents a theoretical Oswald factor
Garner in <b>Torenbeek 1986</b>	inviscid, theoretical	$Q = 1 + \delta$	$P = 0$	Method taken from Torenbeek. See original for further details.
Anderson in <b>Torenbeek 1986</b>	inviscid, theoretical	$Q = 1 + \delta$	$P = 0$	Method taken from Torenbeek. See original for further details.
Labrujere in <b>Torenbeek 1986</b>	inviscid, theoretical	$Q = 1 + \delta$	$P = 0$	Method taken from Torenbeek. See original for further details.
<b>Niță 1984</b>	inviscid, theoretical	$Q = 1 + \delta$	$P = 0$	Empirical, laborious method, which results in theoretical values, that need to be further corrected.
<b>Jenkinson 1999</b>	whole aircraft	$Q = \frac{C_1}{C_2}$	$P = 0$	$C_1 = f(\lambda, A)$ given in the form of a diagram. $C_2$ given in form of equations.

**Table 2.3** Summary of literature study (1 of 2 Tables)

Author / Ref.	Scope	Type of model	Remarks
<b>Samoylovitch 2000</b>	whole aircraft	Theoretical	The theoretical background seems to be incomplete.
<b>Howe 2000</b>	whole aircraft	Unknown	It is a good Aircraft Design equation, yet it lacks the coupling between taper ratio and sweep angle.
<b>Böhnke 2011</b>	inviscid, theoretical	Nonlinear regression	The equation is obtained based on multiple lifting line method, sampling with Latin Hypercube and forming an equation with the help of the tool Eureqa. The result represents a theoretical Oswald factor. Equation is applicable only in the limited investigated design space.
<b>Brandt 1997</b>	whole aircraft	Empirical	Equation is applicable only in a limited design space. Results in small Oswald factors. Large error.
<b>Raymer 1999</b>	whole aircraft	Empirical	Equation is applicable only in a limited design space. Depends only on aspect ratio. Error quite large.
<b>Hoak 1978</b>	whole aircraft	Empirical	Data given in the form of diagrams. Requires time consuming manual process.

## Proposed Method

*Optimum Combination of Taper Ratio and Sweep Angle.* For each sweep, there is an optimal taper ratio that minimizes the induced drag, because it yields a close to elliptical lift distribution. DeYoung delivers a curve that relates the taper ratio to sweep for an approximate elliptical loading (**DeYoung 1955**, pp. 648, Figure 21). An equation that approximates this curve very well was found to be the following exponential equation (with  $e$  standing for Euler number):

$$\lambda_{opt} = 0.45 \cdot e^{-0.0375\varphi_{25}} \quad (2.25)$$

$\varphi_{25}$  is the sweep angle of the 25 % line in degrees. For unswept wings, the optimal taper ratio for achieving a near elliptical loading is 0.45.

*Estimating a Theoretical Oswald Factor.* One of the authors that were investigated, namely **Hörner 1951**, delivers a theoretical Oswald factor (without corrections)  $e_{theo}$  in the form:

$$e_{theo} = \frac{1}{1 + f(\lambda) \cdot A} \quad (2.26)$$

The following fourth order polynomial approximates very well the function  $f(\lambda)$ , given by Hörner in the form of a diagram (see also Figure 2.3):

$$f(\lambda) = 0.0524 \lambda^4 - 0.15 \lambda^3 + 0.1659 \lambda^2 - 0.0706 \lambda + 0.0119 \quad (2.27)$$

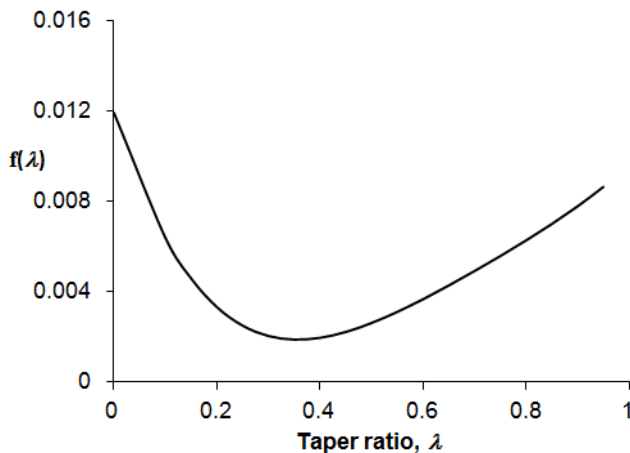

**Fig. 2.3** Function  $f(\lambda)$  from Equation (2.27)

Equations (2.26) and (2.27) are only valid for unswept wings. If wing sweep is present, the minimum from Figure 2.3 has to be shifted to the respective *optimum* taper ratio. The problem is now that, following (2.25), the optimum taper ratio for unswept wings is  $\lambda_{opt} = 0.45$ , whereas another optimum taper ratio is calculated from the derivative of (2.27):  $\lambda_{opt} = 0.357$ .



We stick to the optimum from (2.27), which is a function of sweep. So the taper ratio,  $\lambda$  has to be shifted by an amount:

$$\Delta\lambda = -0.357 + 0.45 \cdot e^{0.0375\phi_{25}} \quad . \quad (2.28)$$

So, Equation (2.26) is modified to:

$$e_{theo} = \frac{1}{1 + f(\lambda - \Delta\lambda) \cdot A} \quad . \quad (2.29)$$

Equation (2.29), with (2.28) and  $f(\lambda - \Delta\lambda)$  from (2.27), represents the expression of a theoretical Oswald factor that accounts for the coupling between taper ratio and sweep. It can play the role of  $u$  in Kroo's expression (**Kroo 2006**), or the role of an  $e_{inviscid}$ .

*Corrections for Fuselage, Zero-Lift Drag and Mach Number Influence.* The method proposed starts from the theoretical evaluation of the Oswald factor given in Equation (2.29) and then corrects it for the fuselage influence, zero lift drag influence and Mach number influence:

$$e = e_{theo} \cdot k_{e,F} \cdot k_{e,D_0} \cdot k_{e,M} \quad . \quad (2.30a)$$

As alternative method, based on **Kroo 2006**, Equation (2.30b) is proposed:

$$e = \frac{k_{e,M}}{Q + P\pi A} \quad , \quad (2.30b)$$

with  $Q = \frac{1}{e_{theo} \cdot k_{e,F}}$ ,  $P = KC_{D,0}$  and  $K = 0.38$ .

The zero lift drag coefficient,  $C_{D,0}$ , required in (2.30b), can be determined from the component based approach (as described next, in Section 2.2.3). If this estimation is unavailable, then  $C_{D,0}$  can be extracted from lift-to-drag ratio and Oswald factor:

$$E_{\max} = \frac{1}{2} \sqrt{\frac{\pi \cdot A \cdot e}{C_{D,0}}} \Rightarrow C_{D,0} = \frac{\pi \cdot A \cdot e}{4 \cdot E_{\max}^2} \quad .$$

However, in this case a loop is formed. To avoid it,

Equation (2.30a) should be used for estimating  $e$ . As such, the first proposal, Equation (2.30a), is recommended for a faster estimation, during initial sizing, when less information is available. The second approach, Equation (2.30b), is recommended when zero-lift drag information is available.

The factor  $k_{e,F}$  depends on the ratio between fuselage diameter and span (is the same as  $s$  in **Kroo 2006**):

$$k_{e,F} = 1 - 2 \left( \frac{d_F}{b} \right)^2 . \quad (2.31)$$

If data is available, the real ratio  $d_F / b$  can be used. Otherwise an average of 0.115 represents a realistic value for all aircraft types (see Appendix A).

**Table 2.4**  $k_{e,F}$  and  $k_{e,D_0}$  factors for each aircraft category

Aircraft category	$d_F / b$	$k_{e,F}$	$k_{e,D_0}$
All	0.115	0.974	-
Jet	0.116	0.973	0.873
Business Jet	0.120	0.971	0.864
Turboprop	0.102	0.979	0.804
General Aviation	0.119	0.971	0.804

The factor  $k_{e,D_0}$  is a statistical factor that accounts for the change of Oswald factor based on a change of zero lift drag roughly depending on the aircraft category (see Table 2.4). The factor was set by matching statistical data given in Appendix A to (2.30a).

The factor  $k_{e,M}$  has the form:

$$k_{e,M} = \begin{cases} a_e \left( \frac{M}{M_{comp}} - 1 \right)^{b_e} + 1, & M > M_{comp} \\ 1, & M \leq M_{comp} \end{cases} , \quad (2.32)$$

$a_e < 0; \quad b_e > 0$

where  $M_{comp}$  stands for compressibility Mach number and has the constant value of 0.3. The constant terms  $a_e$  and  $b_e$  were determined statistically, based on a set of commercial transport aircraft for which aerodynamical data was available. The values are:

$$\begin{aligned} a_e &= -0.001521 \\ b_e &= 10.82 \end{aligned} \quad (2.33)$$

A Prandtl-Glauert correction:  $k_{e,M} = \sqrt{1 - M^2}$ , was also considered, but it matched poorly with experimental data. Equation (2.32) allowed a better manipulation of the correction towards real aircraft data. Figure 2.4 compares  $e$  and  $k_{e,M}$  obtained with the Prandtl-Glauert correction, and with Equation (2.32), for the A320 aircraft. The form given in Equation (2.32) matches real data better.

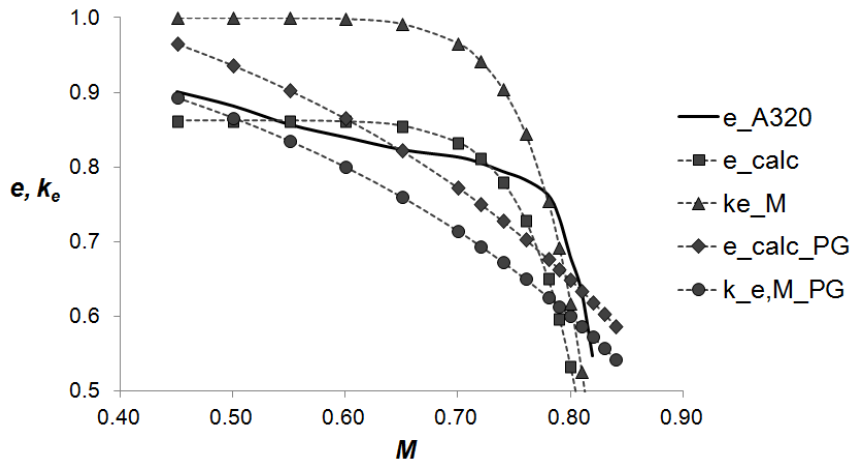

**Fig. 2.4** Calculated Oswald factor ( $e_{\text{calc}}$ ) and Mach number correction ( $ke_M$ ) from Prandtl-Glauert (PG) and own estimation method (without further index), compared with Oswald factor calculated for A320 aircraft ( $e_{\text{A320}}$ )

A dihedral correction was also considered. Yet it was concluded that the dihedral effect would have an insignificant influence, as for most of the aircraft, this angle is quite small. However, if the designer decides to build an aircraft with a significantly higher dihedral, then, the Oswald factor of a such “unconventional” configuration would need to be corrected with an additional  $k_{e,r}$  factor. This factor is discussed in the next section, which deals with estimating the Oswald factor for unconventional, non-planar, configurations.

The proposed method for conventional configurations is simple, logical and delivers quite accurate results. The average deviation of the Oswald factor,  $e$  from literature values (see Table A.2 in Appendix A) is under 4 %.

## 2.2.2 Estimating the Oswald Factor for Non-Planar Configurations

Induced drag can be substantially reduced by increasing wing span. **Kroo 2005** calculates that a 10 % increase in span leads to a 17 % reduction in vortex drag at a fix speed and lift. The drawback of this strategy is, however, a substantially increased structural weight, and hence a higher cost. Non-planar configurations have the potential to reduce drag compared with planar wings of the same span and lift. But their assessment needs to account for both structural and aerodynamic characteristics.

The most known and currently used non-planar configuration is the wing with winglets.

## Wing with Winglets

The simplest approach in understanding winglets is to consider the effect of the winglets equal to that of a wing that prolongs its span with the size of the winglets, as in Figure 2.5.

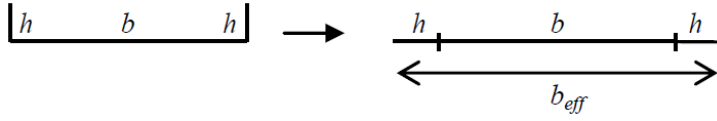

**Fig. 2.5** Simple geometrical consideration for winglets evaluation

The following relations can be written:

$$\begin{aligned} \frac{b_{eff}}{b} &= 1 + 2 \frac{h}{b} \\ C_{D,i} &= \frac{C_L^2}{\pi A e} \\ C_{D,i,WL} &= \frac{C_L^2}{\pi A_{eff} e} = \frac{C_L^2}{\pi A e_{WL}} \\ e_{WL} &= \frac{A_{eff}}{A} \cdot e = \left( \frac{b_{eff}}{b} \right)^2 \cdot e \end{aligned} \quad (2.34)$$

Hence:

$$e_{WL} = \left( 1 + 2 \frac{h}{b} \right)^2 \cdot e \quad (2.35)$$

This simple geometrical consideration aids in understanding the phenomenon, but it is not accurate enough. Proposed is a penalization via a factor  $k_{WL}$ , which accounts for the effectiveness of winglets:

$$e_{WL} = \left( 1 + \frac{2}{k_{WL}} \frac{h}{b} \right)^2 \cdot e = k_{e,WL} \cdot e = e_{theo} \cdot k_{e,F} \cdot k_{e,D_0} \cdot k_{e,M} \cdot k_{e,WL} \quad (2.36)$$

Considering the last equation in the set (2.34) and Equation (2.36), the size of winglets can be extracted and can be used as a parameter during the optimization process:

$$\frac{h_{WL}}{b} = \frac{k_{WL}}{2} \left( \sqrt{\frac{A_{eff}}{A}} - 1 \right) \Leftrightarrow \frac{h_{WL}}{b} = \frac{k_{WL}}{2} \left( \frac{b_{eff}}{b} - 1 \right) \quad (2.37)$$

If the winglet with its height has the same effect as a span increase, then the factor  $k_{WL}$  is 1. This is the geometrical equivalence of the winglet. I.e. the winglet sticking up is as good as folding it down. If, however, the winglet height needs to be divided by 2 and only this reduced height taken as a span increase gives the performance of the winglet, then  $k_{WL} = 2$ .

This is the approach taken by **Howe 2000**. Data from **Kroo 2005** (see Figure 2.9 and Table 2.7) can be used to calculate  $k_{WL} = 2.13$ . **Dubs 1975**, and Zimmer (from **Müller 2003**) have studied the winglets efficiency. They have plotted the ratio  $A/A_{eff}$  which is smaller than one. This also means that winglets sticking up are not as efficient as folding them down. Data points taken from **Dubs 1975** are plotted in Figure 2.6. Equation (2.36) with a penalty  $k_{WL} = 2.45$  represents their graph well.

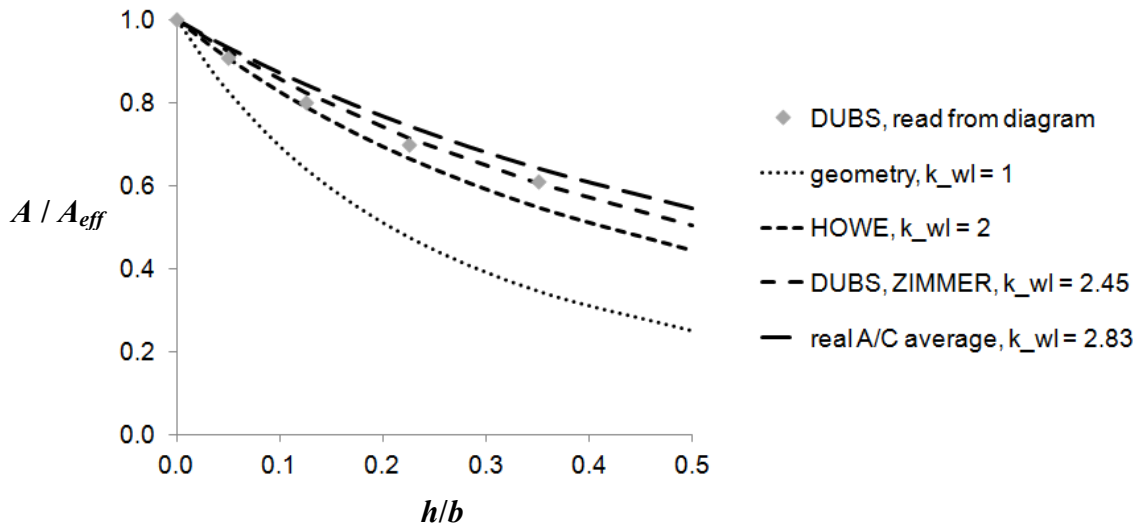

**Fig. 2.6**  $A / A_{eff}$  as a function of  $h/b$ , from different authors

**Whitcomb 1976** from NASA is often quoted in support of winglet efficiency. Whitcomb shows a glide ratio increase due to winglets in wind tunnel measurements compared to a reference configuration without winglets. If however his winglet height would have been used for a span increase, performance gains would have been even greater. It can be estimated from **Whitcomb 1976** that his winglets can be represented by  $k_{WL} = 2.22$ . This puts the NASA measurements well in line with the other data in Table 2.5.

Real aircraft performance with winglets is published by **Boeing 2002** in a form shown in Figure 2.7. Assuming that induced drag is 40 % of total drag in cruise (**Kroo 2001**), we can calculate penalties  $k_{WL}$  for each aircraft given in Figure 2.7. All results are listed in Table 2.5. It can be seen that there is much scatter in data on winglet drag reduction. The average penalty of  $k_{WL} = 2.83$  (obtained from a least square fit) indicates that winglets in real life are on average not performing any better than other sources have indicated.

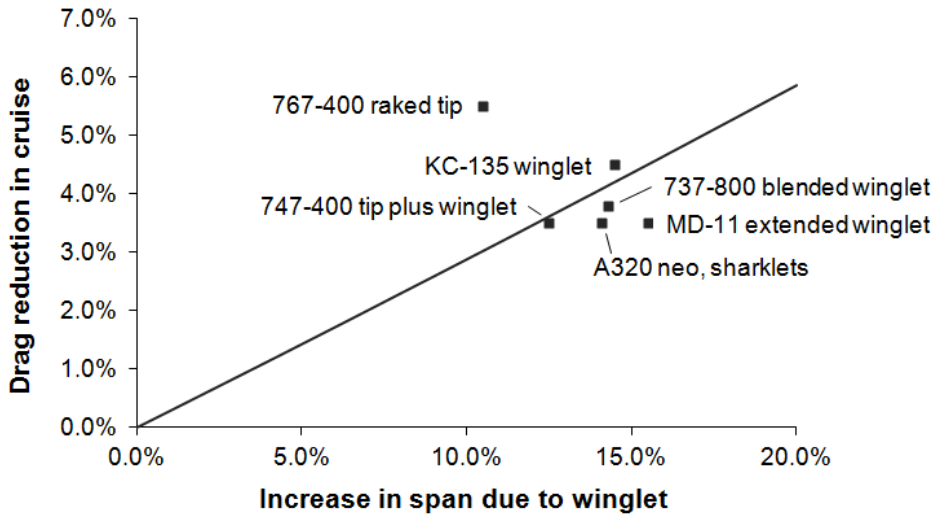

**Fig. 2.7** Increase in span due to winglets as a function of drag reduction in cruise, with data from **Boeing 2002, Airbus 2012**

**Table 2.5** The  $k_{WL}$  factor obtained from different authors

Approach / Source	Reference	$k_{WL}$
Geometry	-	1.00
Howe	<b>Howe 2000</b>	2.00
Kroo	<b>Kroo 2005</b>	2.13
Whitcomb	<b>Whitcomb 1976</b>	2.20
Dubs, Zimmer	<b>Dubs 1975, Müller 2003</b>	2.45
Real aircraft average	<b>Boeing 2002, Airbus 2012</b>	2.83
767-400 raked tip	<b>Boeing 2002</b>	1.58
747-400 tip plus winglet	<b>Boeing 2002</b>	2.92
737-800 blended winglet	<b>Boeing 2002</b>	3.08
KC-135 winglet	<b>Boeing 2002</b>	2.65
MD-11 extended winglet	<b>Boeing 2002</b>	3.62
A320 NEO	<b>Airbus 2012</b>	3.29

The main reason for fitting winglets on an aircraft is to reduce induced drag for a given span. Aircraft are span limited due to airport restrictions and hangar space. Winglets can be an improvement solution for existing aircraft. However, they shift the lift distribution further to the tip of the wing and increase wing bending. Their overall optimization is a multidisciplinary one and rather complicated. But for sure, people agree: winglets look good (**Scholz 2012**).

In OPerA, the effective aspect ratio is varied. If the optimizer increases the aspect ratio that much that the span becomes greater than the airport limitation (listed in Table 2.6), then winglets are added, according to Equation (2.55). The size of the winglets is limited in OPerA to 2.4 m.

**Table 2.6** Aerodrome reference codes and wing span limitations (ICAO 2004)

Code element 1			Code element 2	
Code number	Aeroplane reference field length	Code letter	Wing span	Outer main gear wheel span*
(1)	(2)	(3)	(4)	(5)
1	Less than 800 m	A	Up to but not including 15 m	Up to but not including 4.5 m
2	800 m up to but not including 1200 m	B	15 m up to but not including 24 m	4.5 m up to but not including 6 m
3	1200 m up to but not including 1800 m	C	24 m up to but not including 36 m	6 m up to but not including 9 m
4	1800 m and over	D	36 m up to but not including 52 m	9 m up to but not including 14 m
		E	52 m up to but not including 65 m	9 m up to but not including 14 m
		F	65 m up to but not including 80 m	14 m up to but not including 16 m

\* Distance between the outside edges of the main gear

### Wing with Dihedral

The wing with dihedral reduces to a similar geometrical representation as the wing with winglets (see Figure 2.8).

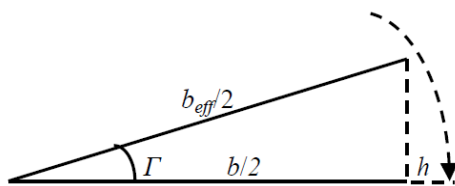

**Fig. 2.8** Geometrical representation of the wing with dihedral

The following relations can be written:

$$\begin{aligned} \frac{b}{2} &= \frac{b_{eff}}{2} \cdot \cos \Gamma \Rightarrow \frac{b_{eff}}{b} = \frac{1}{\cos \Gamma} \\ h &= \frac{1}{2}(b_{eff} - b) \Rightarrow \frac{b_{eff}}{b} = 1 + 2 \frac{h}{b} \\ \frac{h}{b} &= \frac{1}{2} \left( \frac{1}{\cos \Gamma} - 1 \right) \end{aligned} \quad (2.38)$$

Following the same derivation as for winglets, the Oswald factor for a V-shaped wing is:

$$e_{\Gamma} = \frac{A_{eff}}{A} \cdot e \quad (2.39)$$

In other words, the Oswald factor obtained with Equation (2.30) needs to be multiplied by a factor  $k_{e,\Gamma}$ :

$$e = e_{theo} \cdot k_{e,F} \cdot k_{e,D_0} \cdot k_{e,M} \cdot k_{e,\Gamma} \quad . \quad (2.40)$$

From the simple geometrical consideration, the factor would be:

$$k_{e,\Gamma} = \left(1 + 2 \cdot \frac{h}{b}\right)^2 = \left(\frac{1}{\cos \Gamma}\right)^2 \quad . \quad (2.41)$$

A more accurate evaluation is achieved by penalizing the relation with the factor  $k_{WL}$  (Table 2.5):

$$k_{e,\Gamma} = \left(1 + \frac{2}{k_{WL}} \cdot \frac{h}{b}\right)^2 = \left[1 + \frac{1}{k_{WL}} \cdot \left(\frac{1}{\cos \Gamma} - 1\right)\right]^2 \quad . \quad (2.42)$$

### Non-Planar Configurations in General

**Kroo 2005** researched most of the non-planar configurations and delivered the chart in Figure 2.9, where he gives the span efficiency for every type of configuration. He states:

*“Among the well-known results we note that a ring wing has half of the vortex drag of a monoplane of the same span and lift. A biplane achieves this same drag savings in the limit of very large vertical gap and the box-plane achieves the lowest drag for a given span and height, although winglets are quite similar.” (Kroo 2005)*

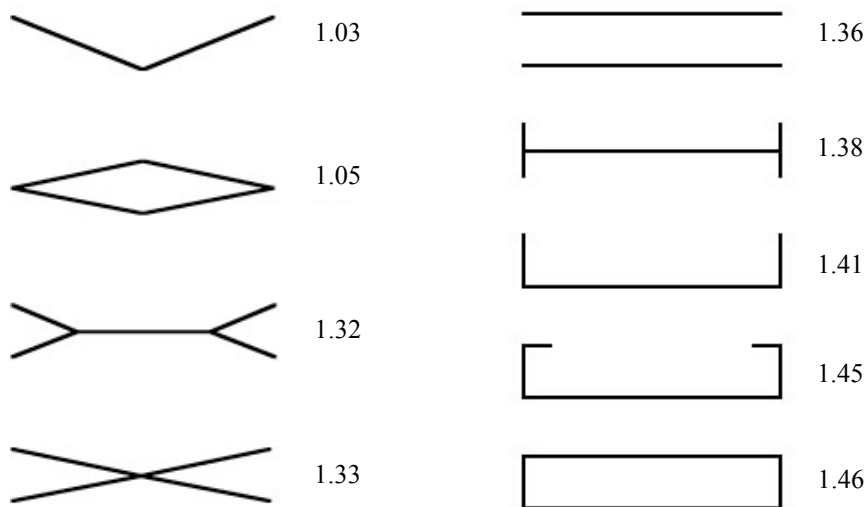

**Fig. 2.9** Span efficiency for various optimally loaded non-planar systems ( $h/b = 0.2$ ) (**Kroo 2005**)

The configurations listed in Figure 2.9 have a vertical extent of 20 % of the wing span (i.e.  $h/b = 0.2$ ). Each design has the same projected span and total lift. The results were generated by specifying the geometry of the trailing vortex wake and solving for the circulation distribution with minimum drag. So, each of the designs is assumed to be optimally twisted (**Kroo 2005**).



If assumed that the Oswald factor can be calculated in a similar fashion as before, via a penalty factor, this time called  $k_{NP}$ , the following relation can be written:

$$e_{NP} = \left(1 + \frac{2}{k_{NP}} \frac{h}{b}\right)^2 \cdot e \Leftrightarrow e_{NP} = k_{e,NP} \cdot e \quad . \quad (2.43)$$



The factor  $k_{WL}$  for wings with winglets and dihedral, investigated above, becomes now a particular case of the  $k_{NP}$  factor. Having the  $k_{e,NP}$  from Figure 2.9,  $k_{NP}$  can be calculated for each configuration, including for the particular case of wing with winglets, value which is already included in Table 2.5 (under the name  $k_{WL}$ ) and wing with dihedral:

$$k_{NP} = 2 \frac{h}{b} \cdot \frac{1}{\sqrt{k_{e,NP} - 1}} \quad . \quad (2.44)$$

Results are listed in Table 2.7.

For wings with winglets, the value is 2.13, while for wings with dihedral, the resulting value is 26.9. There is another literature source from where a  $k_{NP}$  can be calculated for wings with dihedral, namely **DeYoung 1980**. From his Table 2 (pp. 14),  $k_{NP} = 12.1$  was calculated. The dihedral angle, alone, is a bad solution for reducing induced drag. Yet, if required for other reasons (like roll stability), or in combination with other solutions, it brings a 3 % advantage (according to **Kroo 2005**) compared to the reference solution.

**Table 2.7**  $k_{NP}$  calculated for each non-planar configuration from **Kroo 2005**

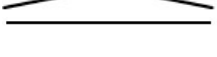
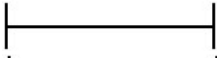
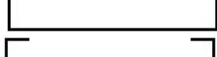
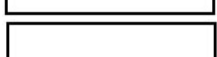
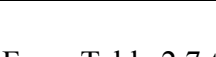
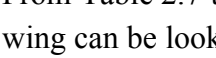
Non-planar configuration	$k_{e,NP}$	$k_{NP}$
	1.03	26.9
	1.05	16.2
	1.32	2.69
	1.33	2.61
	1.36	2.41
	1.38	2.29
	1.41	<b>2.13</b>
	1.45	1.96
	1.46	1.92

From Table 2.7 the most promising concept seems to be *the box wing configuration*. The box wing can be looked at as a particular case of a biplane, where the two wings are connected via winglets.

## The Box Wing Aircraft

Induced drag characteristics of a box wing aircraft compared to a reference conventional aircraft of same span, weight and dynamic pressure can be expressed as follows (see **Schiktanz 2011** for a complete description of the box wing fundamentals):

$$\frac{D_{i,box}}{D_{i,ref}} = \frac{e_{ref}}{e_{box}} = k \quad (2.45)$$

Relation (2.45) can be found in literature as a function of the ratio  $h/b$ , in the general form:

$$\frac{D_{i,box}}{D_{i,ref}} = k = \frac{k_1 + k_2 \cdot h/b}{k_3 + k_4 \cdot h/b} \quad (2.46)$$

In terms of Oswald factors, (2.46) can be rewritten as:

$$\frac{e_{box}}{e_{ref}} = \frac{e_{NP}}{e} = \frac{k_3 + k_4 \cdot h/b}{k_1 + k_2 \cdot h/b} \quad (2.47)$$

For  $h/b = 0$ , the value of the ratio in Equation (2.46) should be  $k = 1$ . This means that, in order to follow logic,  $k_1$  should be equal to  $k_3$ . In this case,  $k = k_2/k_4$  should be the limit for very high  $h/b$  ratio, i.e. at  $h/b = \infty$ .

The factors  $k_1$ ,  $k_2$ ,  $k_3$  and  $k_4$  from different literature sources are given in Table 2.8. From **Prandtl 1924** two equations for biplanes are included for comparison purposes. An own equation for the box wing is created, with the help of a tool called iDrag. iDrag was developed at Virginia Polytechnic Institute and State University by **Grasmeyer 1997**. It calculates induced drag of non-planar configurations composed of multiple panels. Values of  $k$  were obtained from iDrag for seven points ( $h/b$  from 0 to 1) for a reference box-wing aircraft. By using the Excel Solver, the factors  $k_1$ ,  $k_2$ ,  $k_3$  and  $k_4$  were obtained as such as to minimize the deviations between calculated values and iDrag values of  $k$  (read more in **Waeterschoot 2012**). In Table 2.8, two possibilities for forming the equation are listed: first, by letting all parameters to be freely selected by the curve fitting algorithm. This gives a very small deviation, yet  $k_1$  does not result equal to  $k_3$ . Second, by imposing  $k_1 = k_3$ . This returns a set of factors which gives slightly higher deviations, but it respects the logic. Parameters from case (f) in Table 2.8 are proposed here to be used for calculating the Oswald factor for a box wing configuration:

$$\frac{e_{box}}{e_{ref}} = \frac{e_{NP}}{e} = \frac{k_3 + k_4 \cdot h/b}{k_1 + k_2 \cdot h/b} = \frac{1.04 + 2.13 \cdot h/b}{1.04 + 0.57 \cdot h/b} \quad (2.48)$$

Data from Table 2.8 is plotted in Figure 2.10.

In Figure 2.10 plotted is also a curve “(f)  $k$  from iDrag fit to (2.43)”. This curve represents a  $k$  calculated from Equation (2.43). A new  $k_{WL}$  (or  $k_{NP}$ ) resulted by fitting the equation to iDrag data with the aid of MS Solver. The value  $k_{WL} = 4.03$  is higher than literature values given in Table 2.7. For  $h/b = 0.2$ ,  $k_{e,NP}$  is calculated to only 1.21. A value  $k_{e,NP} = 1.46$  is achieved only for as much as  $h/b = 0.42$ . Compared to own iDrag results, Table 2.7 seems to be over-predicting the benefit of non-planar configurations.  $e$  calculated with the Equation based on winglets (2.43) and any value  $k_{WL}$  (or  $k_{NP}$ ) leads always to a value  $k = 0$  for infinite  $h/b$  ratios. Equation (2.48), in contrast, allows different values of  $k$  to be reached asymptotical depending on  $k_2/k_4$  which seems to be required to represent the box wing.

Another author plotted in Figure 2.10 is **DeYoung 1980**. DeYoung proposes an equation in a different form as (2.46), however the results are very similar to  $k$  from Prandtl in case (a) (Table 2.8).

**Table 2.8** The factors  $k_1, k_2, k_3, k_4$  and factor  $k$  when  $h/b$  reaches extremes from different literature sources and own considerations

Case	Configuration	Author	$k_1$	$k_2$	$k_3$	$k_4$	$k$ for $h/b \rightarrow 0$	$k$ for $h/b \rightarrow \infty$	Reference
(a)	Biplane	Prandtl*	1	-0.66	2.1	7.4	0.976	-0.089	<b>Prandtl 1924</b>
(b)	Biplane (2)	Prandtl	1	-0.66	1.05	3.7	0.952	-0.178	<b>Prandtl 1924</b>
(c)	Box wing	Prandtl	1	0.45	1.04	2.81	0.962	0.160	<b>Prandtl 1924</b>
(d)	Box wing	Rizzo	0.44	0.959	0.44	2.22	1	0.432	<b>Rizzo 2007</b>
(e)	Box wing	iDrag best fit	1.304	0.372	1.353	1.988	0.964	0.187	-
(f)	Box wing	iDrag $k_1 = k_3$	<b>1.037</b>	<b>0.571</b>	<b>1.037</b>	<b>2.126</b>	<b>1</b>	<b>0.269</b>	-

\* here, compared to (2.46), a different equation is used:  $k = 0.5 + \frac{k_1 + k_2 \cdot h/b}{k_3 + k_4 \cdot h/b}$ .

It is proposed to calculate the induced drag of a box-wing configuration with (2.48) and parameters  $k_1, k_2, k_3$  and  $k_4$  from iDrag according to case (f). It was found that  $k$  can reach values as low as about 0.27 for  $h/b$  going towards infinity, equivalent to  $e$  going to 3.7. For practical values of  $h/b$ ,  $k$  will always be above 0.6 and  $e$  staying below 1.7.

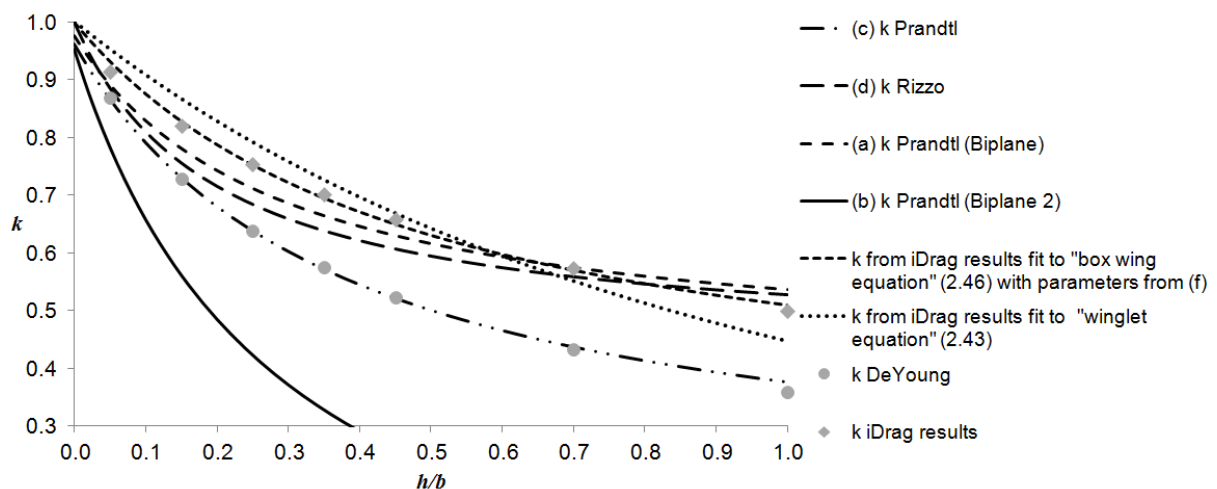

**Fig. 2.10** The factor  $k$  as a function of  $h/b$  ratio for a box wing from different literature sources and own calculations

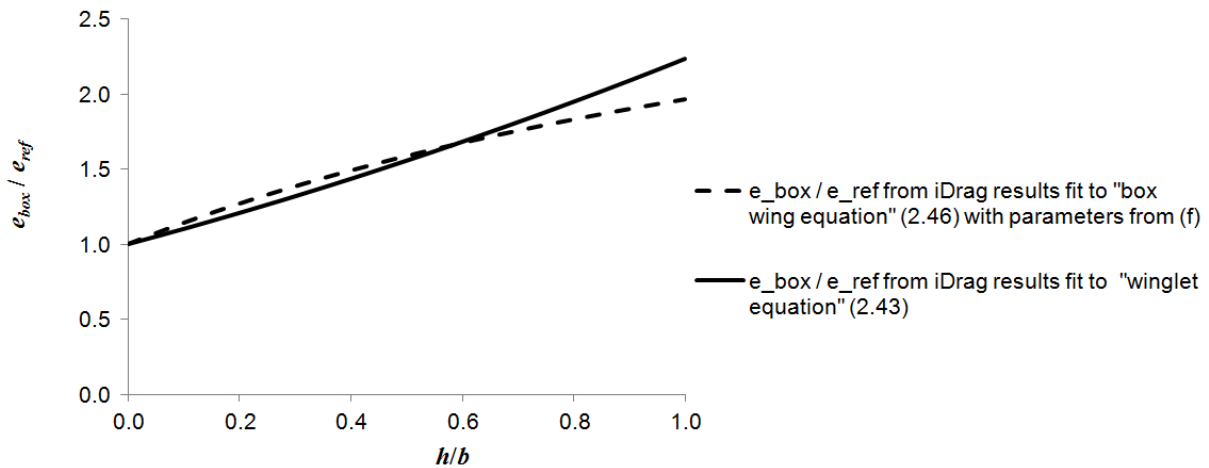

**Fig. 2.11**  $e_{box} / e_{ref}$  for a box wing as a function of  $h/b$  ratio calculated from iDrag results fit to “Box Wing Equation” (2.46) resp. (2.48) and “Winglet Equation” (2.43)

Sections 2.2.1 and 2.2.2 covered the estimation of the Oswald factor for both conventional and unconventional configurations. A reliable method accounting for all basic aircraft parameters was delivered. To summarize, below an enumeration of the contributions brought by this study:

- a relation to express the optimal taper ratio for a given sweep angle;
- a theoretical Oswald factor,  $e$ ;
- a correction factor for  $e$  that accounts for the added lift-dependent drag caused by the modification of the span loading due to the presence of the fuselage;
- a statistical correction factor for  $e$  that accounts for the worsening of the Oswald factor with each aircraft category, due to the worsening of the zero-lift drag characteristics;
- a correction factor for  $e$  that accounts for the effect of the Mach number;
- a correction factor for  $e$  that accounts for the presence of winglets;
- a correction factor for  $e$  that accounts for the effect of the dihedral angle;
- correction factors for  $e$  for basically every non-planar configuration, from Kroo’s chart (Figure 2.9, **Kroo 2005**);
- an equation to estimate the Oswald factor for a box wing configuration starting from a conventional reference aircraft of the same lift and span.

### 2.2.3 Estimating a Refined Zero-Lift Drag from Wetted Area, Form Factor and Interference Drag

The zero lift drag coefficient  $C_{D,0}$  has gained much more attention in Aircraft Design literature compared to the induced drag coefficient  $C_{D,i}$ , expressed in the previous sections through the Oswald factor,  $e$ . In Aircraft Conceptual Design, the most used method to estimate this coefficient is the component build-up method (**Scholz 1999, Raymer 1999**). This method is included in OPerA. Therefore, it was found adequate to briefly summarize the method and mention the improvements that were brought for implementing it in the tool.

For each aircraft component Equation (2.49) is valid:

$$C_{D,0} = \sum_{c=1}^n C_{f,c} \cdot FF_c \cdot Q_c \cdot \frac{S_{wet,c}}{S_{ref}}, \quad (2.49)$$

where  $C_f$  is the friction coefficient,  $FF$  is a form factor and  $Q$  is an interference factor.  $S_{wet}$  stands for component wetted area, and  $S_{ref}$  is a reference area, which is the wing area,  $S_W$ .

#### Friction Coefficients

For laminar flow the following relation can be used (**Raymer 1999**):

$$C_{f,laminar} = 1.328 / \sqrt{Re} \quad . \quad (2.50)$$

For turbulent flow (**Hoak 1978, Raymer 1999**):

$$C_{f,turbulent} = \frac{0.455}{(\log Re)^{2.58} \cdot (1 + 0.144 \cdot M^2)^{0.65}} \quad . \quad (2.51)$$

The Reynolds number in Equation (2.51) is the greater between a so-called *cut-off Reynolds number* (**Hoak 1978, Raymer 1999**) and the Reynolds calculated with the definition equation, i.e.  $Re = (V \cdot l) / \nu$ . The equation for  $Re_{cut-off}$  depends on the Mach number:

$$\begin{aligned} \text{for } M < 0.9: \quad Re_{cut-off} &= 38.21 \cdot \left(\frac{l}{k}\right)^{1.053} \\ \text{for } M \geq 0.9: \quad Re_{cut-off} &= 44.62 \cdot \left(\frac{l}{k}\right)^{1.053} \cdot M^{1.16} \end{aligned} \quad (2.52)$$

The  $k$  factor in Equation (2.52) can be taken from the Table below (**Hoak 1978**):

**Table 2.9** Values for surface roughness

Type of surface	$k$ [mm]
Aerodynamic smooth	0.00000
Metal, polished	0.00013
Metal, unpolished	0.00406
Colored, smooth	0.00635
Colored, military	0.01016

**Form Factors,**

are given in **Hoak 1978** and **Raymer 1999**. Table 2.10 lists the equations for each component.

**Table 2.10** Form factors for each component that contributes to zero-lift drag

Component	Equation	Equation number
Wing Horizontal Tail Vertical Tail	$FF = \left[ 1 + \frac{0.6}{x_t} \left( \frac{t}{c} \right) + 100 \cdot \left( \frac{t}{c} \right)^4 \right] \cdot \left[ 1.34 \cdot M^{0.18} \cdot (\cos \varphi_m)^{0.28} \right],$ <p>where <math>x_t</math> is the position of maximum thickness, <math>t/c</math> is the relative thickness, <math>M</math> is the cruise Mach number and <math>\varphi_m</math> is the sweep at maximum thickness line</p>	(2.53)
Fuselage	$FF_F = 1 + \frac{60}{(l_F / d_F)^3} + \frac{(l_F / d_F)}{400},$ <p>where <math>l_F</math> and <math>d_F</math> are the fuselage length, respectively fuselage diameter</p>	(2.54)
Engine nacelle	$FF_N = 1 + \frac{0.35}{(l_N / d_N)},$ <p>where <math>l_N</math> and <math>d_N</math> are the nacelle length, respectively nacelle diameter</p>	(2.55)

**Interference Factors,**

are given in Table 2.11 (**Scholz 1999**). For OPerA, in the case of wing-nacelle interference, an equation was built in order to express the interference effect as a function of the distance between engine and wing,  $z_P$

$$Q_N = 1.5 - 0.5 \cdot (z_P / D_N) \quad . \quad (2.56)$$

This distance becomes a parameter for optimization. Having  $z_P$  as optimization variable allows testing and answering current industry questions, as it is, for example, the Boeing 737 Max development case. Boeing chose a higher by-pass ratio engine to be replaced on new generation B737; due to the increased engine diameter, the nose landing gear length needed to be increased by 20 cm (**Ostrower 2011**). The change in landing gear could not be avoided, as the distance between engine and wing was too small. An increased distance produces a better interference drag (see Equation. (2.56)). Optimization results obtained with OPerA will show that an increased distance between engine and wing is preferred (see Section 9).

**Table 2.11** Interference factors for each component that contributes to zero-lift drag

Component	Value of Q	Comments
Wing	1.00	Wing is low, middle or high, <i>with</i> Wing-Fuselage fairing
	1.10 ... 1.40	Wing is low, without Wing-Fuselage fairing
Fuselage	1.00	--
Horizontal and Vertical Tail	1.04	Conventional
	1.08	H Tail
	1.03	V Tail
Engine	1.5 $Q_N = 1.5 - 0.5 \cdot (z_P / D_N)$	Engine directly on Wing or Fuselage There is a distance, $z_P$ between engine and Wing / Fuselage

**Wetted Areas,**

are given in Table 2.12 for each component (**Torenbeek 1986** for fuselage, wing and empennage and **Herrmann 2010** for engine). For the wetted area of the pylon a geometrical approximation was used, based on typical pylons. The purpose was to express this wetted area as a function of the distance between engine and nacelle,  $z_P$  (see Equation (2.60)).

For engine wetted area **Herrmann 2010** was chosen instead of **Torenbeek 1986** due to its dependency on by-pass ratio.

**Table 2.12** Wetted areas for each component that contributes to zero-lift drag

Component	Wetted area $S_{wet}$	Equation Number
Fuselage	$S_{wet,F} = \pi \cdot d_F \cdot l_F \cdot \left(1 - \frac{2}{\lambda_F}\right)^{2/3} \left(1 + \frac{1}{\lambda_F^2}\right)$ , where $\lambda_F = l_F / d_F$	(2.57)
Wing Horizontal Tail Vertical Tail	$S_{wet,W} = 2 \cdot S_{exp} \cdot \left(1 + 0.25 \cdot (t/c) \cdot \frac{1 + \tau \cdot \lambda}{1 + \lambda}\right)$ , where $\lambda$ is the taper ratio and $\tau$ is the ratio between thickness ratio at tip and thickness ratio at root	(2.58)
Nacelle	$S_{wet,N} = 0.9 \cdot \pi \cdot (D_N \cdot L_N)$	(2.59)
Pylon	$S_{wet,P} = 3 \cdot l_P \cdot z_{P,min} \cdot k_{P,3} + 2 \cdot w_P \cdot z_{P,min}$ with $l_P = k_{P,1} \cdot L_N$ , $w_P = k_{P,2} \cdot D_N$ where $l_P$ is pylon length; $w_P$ is pylon width; $z_{P,min}$ is the minimum distance between engine pylon and wing; $k_{P,1}$ , $k_{P,2}$ , $k_{P,3}$ are statistical factors: $k_{P,1} = 1.25$ $k_{P,2} = 0.19$ $k_{P,3} = 1.7$	(2.60)

The  $C_{D,0}$  determined with the component build-up method represents only a part of the non-lift-dependent drag. Equation (2.49) may include in fact additional terms, such as  $C_{D,misc}$ , for miscellaneous components, as landing gear drag;  $C_{D,L+P}$  for cabin pressure leakage, doors and antennas, or  $C_{D,wave}$  accounting for flight at high speed. In this work, included is only  $C_{D,wave}$ .

$$C_{D,0} = \sum_{c=1}^n C_{f,c} \cdot FF_c \cdot Q_c \cdot \frac{S_{wet,c}}{S_{ref}} + C_{D,wave} \quad (2.61)$$

The wave drag can be calculated with Lock's empirically-derived shape of the drag rise (**Mason 2006**):

$$C_{D,wave} = 20(M - M_{crit})^4, \quad (2.62)$$

where  $M_{crit}$  calculated from the drag divergence Mach number,  $M_{DD}$  is:

$$M_{crit} = M_{DD} - \Delta M_{crit}, \quad (2.63)$$

with  $\Delta M_{crit} = 0.1$  (**Mason 2006**).

In OPerA the interference factors and the zero-lift drag are corrected through a factor determined based on a reference aircraft, for which accurate data was available. These corrections account also for the neglected additional drag terms, mentioned before. They are described in more detail in Section 4.

## 2.2.4 Estimating Maximum Lift-to-Drag Ratio

Now that a method for estimating the Oswald efficiency factor and zero-lift drag coefficient are available, the maximum lift-to-drag ratio can be more accurately expressed and can incorporate the influence of key design parameters.

The two equations available to estimate the maximum lift-to drag ratio are (2.12) and (2.13). Here they are again:

$$E_{max} = \frac{1}{2} \sqrt{\frac{\pi \cdot A \cdot e}{C_{D,0}}} \quad (2.64)$$

$$E_{max} = k_E \sqrt{\frac{A}{S_{wet} / S_W}} \quad (2.65)$$

$$k_E = \frac{1}{2} \sqrt{\frac{\pi \cdot e}{c_f}}$$

The calculated wetted areas (Table 2.11) allow an accurate estimation of the  $S_{wet} / S_W$  ratio. For A320 aircraft this ratio was calculated as 6.30. The Oswald efficiency factor is 0.78, for a cruise Mach number of 0.76. The zero-lift drag was calculated as 0.0189. These deliver a maximum Lift-to-Drag ratio of 17.59.



In OPerA the user has the possibility *to choose the degree of accuracy* in estimating  $E_{max}$  and thus understand the design space more easily. Section 7 presents this in more detail.

### 2.2.5 Discussion on Natural Laminar Flow

Laminar flow, natural or induced, is cited in many international research projects, such as the European research program Clean Sky (**Clean Sky 2011**), as a promising improvement of wing efficiency. Other research institutions that recently approached this topic are German Aerospace Center (**Hepperle 2008**), NASA (**Bradley 2010**), Virginia Tech (**MAD 2011**).

The topic is not new. Natural laminar flow has been addressed since the beginning of aeronautics and still didn't cease to challenge researchers. Today, the development of modern optimization algorithms (e.g. in **Driver 2006**, or **Seyfert 2012**) allows a more accurate prediction of the laminar-turbulent transition and hence, more accurate shape optimizations. Also, the development of construction techniques that enable the production of smoother aerodynamic surfaces, reduce the friction coefficients, and hence enable laminar flow on greater surfaces as before (**Dodbele 1986**).

Table 2.13 lists the potential extension of NLF on each aircraft component and the anticipated drag reduction, in the vision of **Holmes 1986**.

**Table 2.13** Potential percentage of NLF and total drag reduction calculated at  $M = 0.7$  for a business jet (**Holmes 1986**)

Component	% of body length NLF	% of drag reduction
Wing	50	12
Horizontal Tail	30	2
Vertical Tail	30	1
Fuselage	30	7
Nacelles	30	2
Total		24

The transition from laminar to turbulent has drastic effects on drag. The point where the flow is likely to become turbulent is after the profile crest (**Kroo 2006**). Flow separation due to increased pressure drag can be delayed by shaping the airfoils so that their thickest point is more aft and less thick (laminar profiles). In this way, the laminar flow pushes the transition of the boundary layer further aft. The transition from laminar to turbulent is influenced by the profile shape (through velocity and pressure distribution on the profile), sweep angle (through leading edge sweep) and Reynolds number.

There are two dominant types of instabilities that enable the transition from laminar to turbulent. One is the two-dimensional Tollmien-Schlichting (T-S) instability (triggered for example by a sound disturbance), and the other one is the three-dimensional crossflow

instability (caused by the wing sweep, as the air tends to move along the leading edge instead of over the wing). At lower Reynolds numbers it is easier to maintain laminar flow. However, transport aircraft fly at higher speeds and sweep is required. For swept wings, damping T-S growth is made by achieving favorable pressure gradients. In the same time, to reduce the growth of the crossflow vortices, less favorable gradients are imposed (The growth rate of crossflow vortices is high in the region of rapidly falling pressure near the leading edge). Interaction can occur between the crossflow vortices and T-S waves to the detriment of laminar stability. The technical challenge is to meet both of these conflicting pressure gradient requirements and to avoid catastrophic growth of either the two- or three-dimensional instabilities (**Holmes 1986**).

The position on chord where transition from (natural) laminar to turbulent flow takes place is represented by a Reynolds number called transition Reynolds number,  $Re_T$ . This local Reynolds number is expressed by:

$$Re_T = Re \frac{x_T}{c} , \quad (2.66)$$

where  $x_T$  represents the chordwise position of the transition.  $x_T / c$  represents exactly the proportion of laminarity,  $k_{laminar}$ .

In order to address, and asses during preliminary design stage, with OPerA, the effect of NLF on aircraft designs and to improve the optimization process, a simple equation was necessary that could account for the effect of sweep and Reynolds number on laminarity.

**Hepperle 2008** gives an overview of the experimental aircraft on which laminar flow was tested in the last decades. The author represents the NLF achievements in a diagram as a function of leading edge sweep and Reynolds number (see Figure 2.12). From this empirical diagram (more precisely the dashline representing the boundary between NLF and HLF) an equation can be extracted, that can be easily implemented in the preliminary design paradigm to estimate the percentage of laminarity,  $k_{laminar}$ , when estimating the zero-lift drag coefficient:

$$Re_T / 10^6 = -0.0112\varphi_{LE}^2 - 0.1107\varphi_{LE} + 22.167 \quad . \quad (2.67)$$

Leading edge sweep can be expressed from the 25 % sweep with:

$$\tan \varphi_m = \tan \varphi_n - \frac{4}{A} \left[ \frac{n-m}{100} \cdot \frac{1-\lambda}{1+\lambda} \right] , \quad (2.68)$$

where  $n = 0^\circ$  and  $m = 25^\circ$ ,  $A$  = aspect ratio and  $\lambda$  = taper ratio.

In Figure 2.12, FSW and BSW stand for forward and, respectively backward swept wings. TS stands for Tollmien-Schlichting, which, as stated before, is a normal, two-dimensional instability. TS and CF (crossflow instability) occur at common sweeps, ranging between 10° and 30°, while at very high swept supersonic aircraft, CF dominates.

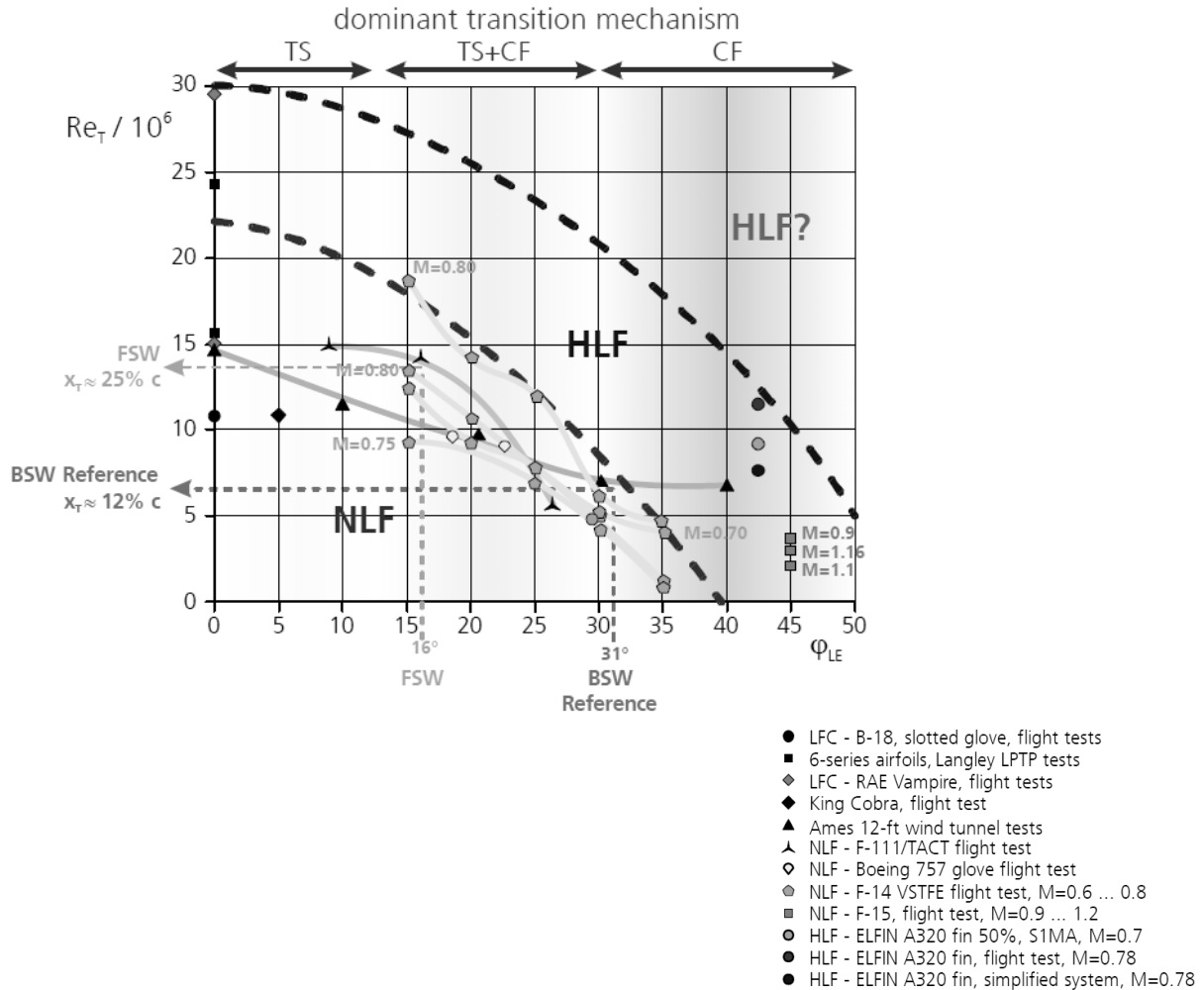

**Fig. 2.12** Laminar flow limits for swept wings (Hepperle 2008)

An advantageous configuration for natural laminar flow is the strut braced wing, which favors lower sweeps, and hence enables increased areas of with NLF, compared to cantilever wings.

## 2.2.6 Discussion on Strut Braced Wings

Conventional aircraft designs use cantilever wings. A braced wing configuration represents an alternative to larger changes in the current design practice that promises some advantages compared to the cantilever wing:

- Possibility of *reducing wing mass* (as strut force reduces wing bending);
- Possibility of *increasing aspect ratio*, hence *reducing induced drag*;
- Possibility of *reducing thickness ratio*, hence *reducing wave drag*;
- Possibility of *reducing sweep*, hence increasing areas for NLF, hence *reducing zero-lift drag*.

The need of reducing induced drag (which is about 40 % from the total drag in cruise according to **Kroo 2001**), lead to the idea of increasing aspect ratio. Aspect ratio is limited by structural considerations as well as airport limitation. With a strut-braced wing (SBW) aspect ratio can be increased, and hence induced drag reduced, without a mass penalty: the strut force reduces wing bending, and the wing can be lighter. A lower wing thickness becomes possible, which translates into a reduced wave drag. If wave drag is reduced, sweep can be smaller. A small sweep and a high aspect ratio enable increased surface for natural laminar flow (NLF). Such a wing, with increased performance (increased lift-to-drag ratio) would require a smaller engine, which translates into reduced fuel consumption and cost. Drawbacks are: increased interference drag, wetted areas and friction coefficients, so a slight increase of the zero-lift drag is expected. This should be, however, acceptable under the consideration of the more important aerodynamic gaining named before. Another challenge would be the buckling problem that may occur at high aspect ratio wings. Buckling could be prevented by properly designing the strut – at the cost of additional mass, or by introducing an innovative mechanism that would prevent the buckling problem without adding mass.

The above are ideas were debated already in the early 50's. Research has been performed on and off since then. Most of the studies provide solutions to arising problems, so that ultimately the advantages dominate and the concept remains a promising one. This is the reason why this configuration is discussed, implemented and tested in this work. This paragraph provides a summary of the literature findings in light of the Preliminary Aircraft Design methodology. It also describes the implementation of braced wing technology into the methodology and the afferent software, OPerA.

### Literature

Often quoted as pioneer defender of the concept, is Werner Pfenninger (**Pfenninger 1958**). Detailed studies have been performed by NASA in the 80s. The concept seemed to have been forgotten, until the topic was readdressed from 1998 until present by the MAD Center Virginia Tech in the frame of university and industry cooperation. Later, European

universities and industry also investigated the topic<sup>1</sup>. Table 2.14 attempts to summarize the most important findings of the last three decades. It lists the most important studies of the MAD Center, as well as other literature sources, and the main conclusions of the authors.

**Table 2.14a** Authors researching the strut-braced wing configuration and their main conclusions

Period	Author & Reference	Title and Topic	Main conclusions
1958-1981	<b>Kulfan 1978</b>	<i>“Wing Planform Geometry Effects on Large Subsonic Military Transport Airplanes”</i>  Preliminary design study of large turbulent flow military transport aircraft with cantilever and braced wing, addressing the following fields: geometry, cruise speed, performance and structure.	The best cantilever wing planform for minimum takeoff gross weight, and minimum fuel requirements, as determined using statistical weight evaluations, has a high aspect ratio, low sweep, low thickness/chord ratio, and a cruise Mach number of 0.76.
	<b>Park 1978</b>	<i>“The Effect of Block Fuel Consumption of a Strutted vs. Cantilever Wing for a Short-Haul Transport Including Aeroelastic Considerations”</i>  Comparison of the block fuel consumption of cantilever and strut-braced wing.	Struts save wing mass. Increase in strut thickness for coping with buckling at -1g condition increase strut drag and fuel consumption compared to cantilever wing design.
	<b>Jobe 1979</b>	<i>“Wing Planforms for Large Military Transports”</i>	Document not available.
	<b>Turriziani 1980</b>	<i>“Preliminary Design Characteristics of a Subsonic Business Jet Concept Employing an Aspect Ratio 25 Strut-Braced Wing”</i>  Study for determining the fuel efficiency advantages of replacing the conventional wing of a transatlantic-range business jet with a larger, strut-braced, aspect ratio 25 wing.  Aerodynamic improvements of lifting struts were considered.	The strut-braced wing airplane: cruises at higher altitudes and lower speeds than the conventional wing configuration, so it's less productive; has a much lower wing loading than the conventional wing airplane; reduces the total mass for a given wing planform; has improved aerodynamic performance; saves fuel, yet it is more expensive to build.
	<b>Smith 1981</b>	<i>“A Study of High-Altitude Manned Research Aircraft Employing Strut-Braced Wings of High Aspect Ratio”</i>  Research of the effect of increased aspect ratio on structural mass, system mass, maximum range and altitude for configurations with and without strut bracing.	Higher aspect ratios improve range. If additionally the wing is braced, the improvement is 12 % higher, due to wing mass reduction and aerodynamic gain provided by lifting struts.

<sup>1</sup> The first CPACS (Common Parametric Aircraft Configuration Schema) / RCE Symposium, *Cooperation in Aircraft Design*, that took place in Hamburg on 15, 16 of March 2012 showed that industry as well as the scientific aircraft design community recognized the potential of the braced wing configuration.

**Table 2.14b** Authors researching the strut-braced wing configuration (continuation)

Period	Author & Reference	Title and Topic	Main conclusions
1998-present	<b>Grasmeyer 1998a</b> <b>Grasmeyer 1998b</b>	<p><i>"Multidisciplinary Design Optimization of a Strut-Braced Wing Aircraft with Tip-Mounted Engines"</i> (Report)</p> <p><i>"Multidisciplinary Design Optimization of a Strut-Braced Wing Aircraft"</i> (Master Thesis)</p> <p>Investigation of the use of truss-braced wing concepts for improving performance of transonic transport aircraft. Setting up MDO analysis code, assessment of basic configurations, evaluation of NLF utilization and engine position on wing.</p>	<p>The study delivers the percentual improvements that could be brought by a braced wing concept. The result is a higher aspect ratio, lower thickness-to-chord ratio, lower sweep wing, obtained with a single, fully laminar strut design. The buckling of the strut under the -1g load condition proved to be the critical structural challenge in the single-strut configuration. Interference drag predicted to be negligible.</p>
	<b>Naghshineh -Pour 1998</b>	<p><i>"Structural Optimization and Design of a Strut-Braced Wing Aircraft"</i> (Master Thesis)</p> <p>Completes the results of Grasmeyer with a wing bending material weight calculation procedure that accounts for the strut. For selected critical load conditions, buckling is identified as a problem and addressed by using an innovative mechanism for the struts.</p>	<p>More wing weight reduction is obtained by optimizing the strut force, a strut offset length, and the wing-strut junction location. Proves potential of the use of active load alleviation control to reduce the wing bending material weight. Underlines the need of aeroelastic and structural dynamic analysis.</p>
	<b>Tétrault 2000</b>	<p><i>"Numerical Prediction of the Interference Drag of a Streamlined Strut Intersecting a Surface in Transonic Flow"</i> (Doctoral Thesis)</p> <p>Provides relationships to estimate the interference drag of wing-strut, wing-pylon, and wing-body arrangements, by curve fitting CFD calculation results.</p>	<p>Rapid increase of the interference drag as the angle of the strut deviates from a position perpendicular to the wall. When the (<i>tlc</i>) ratio of the strut is reduced, the flowfield is disturbed only locally at the intersection of the strut with the wall.</p>
	<b>Ko 2000a</b> <b>Ko 2000b</b>	<p><i>"The Role of Constraints and Vehicle Concepts in Transport Design: A Comparison of Cantilever and Strut-Braced Wing Airplane Concepts"</i> (Master Thesis and AIAA Paper)</p> <p>Analysis of four different cantilever and strut-braced wing configurations from a MDO perspective. Refinements of the existing analysis codes, comparison of two alternatives to calculate mass equations (FLOPS and LMAS). Investigation of the effect of design constraints on each configuration. Analysis of a double-deck configuration.</p>	<p>The two alternatives to calculate mass yielded similar results. The aircraft range proved to be the most crucial constraint in the design of all selected configurations. SBW configurations are less sensitive. A double-deck configuration delivers a small improvement in takeoff mass and fuel mass over the single-deck fuselage SBW, due to reduced interference drag at the resulting greater wing/strut intersection angle.</p>

**Table 2.14c** Authors researching the strut-braced wing configuration (continuation)

Period	Author & Reference	Title and Topic	Main conclusions
1998-present	<b>Gundlach 2000</b> <b>Gundlach 1999</b>	<p><i>"Multidisciplinary Design Optimization of a Strut-Braced Wing Transonic Transport"</i> (Paper)</p> <p><i>"Multidisciplinary Design Optimization and Industry Review of a 2010 Strut-Braced Wing Transonic Transport"</i> (Report)</p> <p>Comparison of the strut-braced wing (SBW) to the cantilever wing from an MDO perspective. Research is performed with the Virginia Tech MDO code. The paper presents general results based on a refined, evaluation of previous studies.</p>	<p>Significant reductions in take-off gross weight. Improved fuel consumption and smaller engine size, hence less costs and pollution, including noise pollution. SBW enables laminar flow, transonic wave drag reduction and other aerodynamic gains. Is likely to have a more favorable reaction from the public and crew than other unconventional competing configurations.</p>
	<b>Gern 2000a</b>	<p><i>"Passive Load Alleviation in the Design of a Strut-Braced Wing Transonic Transport Aircraft"</i> (Paper)</p> <p>The same MDO topic as above, but considering aeroelastic deformations of the wing and passive load alleviation. Analysis of three different SBW configurations with an additional module of the MAD code. Investigations with both rigid and flexible wing sizing.</p>	<p>The use of a strut enables the use of thin airfoils. Using thin airfoils without a strut would increase wing mass by 40 %. Strut position affects spanload distributions and deformations. Flexible wing sizing has little effect on the overall mass optimization results and requires a higher amount of calculation time. The cantilever wing benefits more from the flexible load calculation than SBW wings. Strut twist moment provides substantial load alleviation and hence significant reductions in structural mass.</p>
	<b>Gern 2000b</b>	<p><i>"Flexible Wing Model for Structural Wing Sizing and Multidisciplinary Design Optimization of a Strut-Braced Wing"</i> (Paper)</p> <p>Description of a structural and aeroelastic model for wing sizing and mass calculation of a SBW. The aeroelastic model accounts for wing flexibility and spanload redistribution during in-flight maneuvers.</p>	<p>Significant influence of the strut on the bending material weight of the wing. The strut enables thin airfoils without weight penalty and influences wing spanload and deformations. Employment of the strut twist moment for further load alleviation leads to increased savings in structural mass.</p>

**Table 2.14d** Authors researching the strut-braced wing configuration (continuation)

Period	Author & Reference	Title and Topic	Main conclusions
1998-present	<b>Sulaeman 2001</b>	<p><i>“Effect of Compressive Force on Aeroelastic Stability of a Strut-Braced Wing”</i></p> <p>Investigation of the effect of compressive force on aeroelastic stability of the SBW. Developing of a procedure to generate wing stiffness distribution for detailed and simplified wing models and to include the compressive force effect in the SBW aeroelastic analysis. Sensitivity studies performed to generate RS equations for the wing flutter speed as functions of several design variables, providing in the end a tool and trend data to study SBW.</p>	For the selected fuselage-mounted engine, SBW configuration, the author concludes that the detrimental effect of the compressive force to the wing buckling and flutter speed is significant if the wing-strut junction is placed near the wing tip.
	<b>Moen 2010</b>	<p><i>“Truss-Braced Wing Topology Optimization Studies”</i></p> <p>Investigation of long wing-span (of a high AR SBW aircraft) with respect to structural issues and optimum shape. Utilization of recent topology optimization algorithms to find maximum stiffness topologies that could be employed in the MDO research of SBW. The minimum-compliance approach to topology optimization is used to produce stiffened SBW configurations, with varying levels of geometric complexity, for given boundary conditions.</p>	Decreasing design complexity resulted in increased wing tip deflections as structural material was shifted towards the wing cantilever root. A frame structural analysis of a continuum topology with three diagonal wing supports demonstrated preliminarily that improved performance, i.e. increased stiffness and reduced weight, can be achieved if the wing supports are connected with an integral moment connection at the top and bottom truss chords.
	<b>Gern 2005</b>	<p><i>“Transport Weight Reduction through MDO: The Strut-Braced Wing Transonic Transport”</i></p> <p>Summation of the results gathered in a five-year research period on braced wings. Optimization of braced wing configurations using the MDO code. Analysis of four configurations: cantilever wing, SBW with fuselage mounted engines, wing engines and wingtip mounted engines.</p>	Significant mass reduction compared to existing transonic transport concepts. Aerodynamics and structures are coupled. The concept scales to all sizes of transonic airplanes. The results were reviewed and validated by other design teams.
	<b>Greatwood 2006</b>	<p><i>“Strut Braced Wing Aircraft - Preliminary Engineering Definition Report”</i></p> <p>The topic is addressed, in the frame of an industry-university project for students with the purpose to optimize a short-range design as A320 for a low cost airline. Spreadsheet calculations are employed.</p>	Strut braced wing (with telescopic strut, high aspect ratio and further out, wing mounted engines) is selected as winning configuration, despite the risks. Further conclusions and results were TBD and unavailable.



After Pfenninger, studies on braced wing were performed by NASA, Boeing and Lockheed in the 80s, as it is shown in Table 2.14. In the late 90s up to 2000 a more intense research is initiated by NASA together with the MAD Center of Virginia Tech. The initial framework for studying SBW at MAD Center was set by Grasmeyer with his Master Thesis and AIAA Paper. He sets the basic infrastructure, i.e. the basic version of the MDO code used to perform the investigations. He also confirms some of the known benefits and identifies the major challenges. Naghshineh-Pour performs a bending material weight analysis. Tétrault, and later A. Ko, address interference drag. Further refinements and substantiation of the work are presented in the papers of Gundlach. Structural issues are addressed by Gern (passive load), Sulaeman (Flutter) and later Moen (topology optimization). In Europe research on SBW was limited, and here, the concept seemed to have been forgotten. In 2006 Airbus investigates the configuration in the frame of a student project together with the University of Bristol. The SBW configuration is selected as winner among other four configurations, despite the assessed risks. Nevertheless, no larger considerations of the concept were followed by industry.

To summarize, braced wings allow an increase in aerodynamic efficiency and reduction in mass, which also reflects on propulsion: smaller, less expensive engines would be required. This occurs at a small penalty in zero-lift drag: wetted area increases, as well as interference drag between strut and wing, respectively strut and fuselage.

### Implementation in OPerA

To support also design of innovative configurations, such as SBW, the study of this concept was made possible in the tool developed, OPerA. The user has the alternative to select between a cantilever and a strut-braced wing configuration. At the level of detail in OPerA the reduction in mass promised by the braced wing is accounted for through a wing mass correction factor from **Torenbeek 1992**. Based on the equation from **Torenbeek 1986**, the following correlation can be written:

$$\frac{m_{W,ST}}{m_W} = \left(\frac{b_{ST}}{b}\right)^{1.35} \cdot \frac{1 + \sqrt{\frac{b_{ref}}{b_{ST}}}}{1 + \sqrt{\frac{b_{ref}}{b}}} \cdot 0.7, \quad (2.69)$$

where  $b_{ref}=1.905$  m;  $ST$  stands for strut.

In Equation (2.69), the correction factor of 0.7 is proposed by **Torenbeek 1986**. When calculating with Howe's assumptions (**Howe 2000**), a value of 0.78 results. In OPerA this factor has a default value of 0.7, but it can be changed by the user.

The zero-lift drag and interference drag are amended by calculating the strut's friction coefficient, form factor, wetted and interference factor. The following assumptions are used:

$$\begin{aligned}
c_{MAC,ST} &= 0.5 \cdot c_{MAC} \\
(t/c)_{av} &= 0.1 \\
x_m &= 0.5 \\
\varphi_{25} &= 0^\circ; \quad \varphi_m = 0^\circ \\
(b/2)_{ST} &= 0.4 \cdot (b/2)_W \\
L_{ST} &= \sqrt{(b/2)_{ST}^2 + d_F^2} \\
A_{ST} &= \frac{L_{ST}}{c_{MAC,ST}} \\
\lambda_{ST} &= 1 \\
Q_{ST} &= 1.04
\end{aligned} \tag{2.70}$$

The wing-strut interference drag,  $Q_{ST}$  was predicted to be almost negligible by **Tétrault 2000**, **Grasmeyer 1998a**. A value of 1.04 was chosen.

### 2.2.7 Estimating Thrust Specific Fuel Consumption

The thrust specific fuel consumption (TSFC) is required for calculating the Breguet factor used to estimate the fuel fractions for cruise and loiter and it greatly reflects on the aircraft maximum take-off mass. A 10 % reduction in TSFC reduces the maximum take-off mass by 5.7 % (according to the possible / available estimations during Preliminary Sizing and Conceptual Design).

One of the main parameters that can have a positive influence on specific fuel consumption (SFC) is the engine By-Pass Ratio (BPR). For increasing fuel efficiency, the tendency is to see next generation engines with increased BPR. In a simple Preliminary Sizing process BPR is given, as a constant value. In OPerA a Thrust Specific Fuel Consumption (TSFC) model was sought, able to cover also higher by-pass ratios.

A literature survey was made and all available models were tested. Among the researched authors, are: **Howe 2000**, **Scholz 1999**, **Herrmann 2010**, **Mattingly 1996**, **Svoboda 2000**, **Sforza 2011**, **Stanford 2011**.

The equations were tested on engines that are currently found on medium range aircraft, of the class of A320 aircraft. For these engines the TSFC values were known from literature, so a comparison was possible. In Table 2.15, their TSCF is given in kg/N/s:

**Table 2.15** Engines found on medium range aircraft and their TSFC values used as reference for comparing the approaches of different authors for estimating TSFC (**Roux 2002**)

Engine	CFM56 5A1	CFM56 5B4	V2500 A1	V2527 E-A5
TSFC [kg/N/s]	$1.69 \cdot 10^{-5}$	$1.54 \cdot 10^{-5}$	$1.65 \cdot 10^{-5}$	$1.54 \cdot 10^{-5}$

During the methods evaluation, the following observation was taken into account: when performing methods evaluations, technology improvements play an important role; any engine comparison should account for the year in which the engine was built. For example, the newer CFM56 5B4 has better TSFC even if the BPR is smaller (see Table 2.15). This is due to other engine improvements that have reduced the TSFC, as the B4 engine is more modern. Thus, a comparison based on BPR should be made only for engines *from the same development time*, that use the same technology level, i.e.: CFM 56 A1 with V2500 A1 and CFM 56 B4 with V2527 A5.

The selection criteria for the most adequate method were:

- minimum deviation from the TSFC values in Table 2.15,
- dependency of the equation on BPR,
- validity of the equation on a large domain of definition.

Minimum deviations from real engines would ensure that the method works. Dependency on BPR would give a measure of quantification of the impact of this important parameter during an optimization process. A large domain of definition would cover the case when an optimization process would deliver a design with very high BPR – for which the method would still need to be valid.

Table 2.16 presents the behaviour of the tested methods with respect to the above criteria. The one with rank 1 is selected for implementation in OPerA. Table 2.17 presents the values of the deviations for the best ranked models.

**Table 2.16** Evaluation of methods for estimating TSFC. Selection of the best method.

Author Reference	Criteria	Deviation from values in Table 2.15	Dependency on By-Pass Ratio	Size of domain of definition	Ranking
<b>Mattingly 1996</b>		+++	No	+++	6
<b>Sforza 2011</b>		-	No	+	7
<b>Howe 2000</b>		+++	Yes	+	2
<b>Isikveeren 2002</b>		+	Yes	-	5
<b>Svoboda 2000</b>		+	Yes	+	4
<b>Herrmann 2010</b>		+++	Yes	+++	1
ESDU 73019 in <b>Roux 2002</b>		++	Yes	+	3
<b>Roux 2002</b>		++	Yes	+	3

**Table 2.17** Comparison of TSFC models

	TSFC		TSFC		TSFC		TSFC		Observations
	[Kg/N/s]	$\Delta$	[Kg/N/s]	$\Delta$	[Kg/N/s]	$\Delta$	[Kg/N/s]	$\Delta$	
A320-200	CFM56 5A1	[%]	CFM56 5B4	[%]	V2500 A1	[%]	V2527 E-A5	[%]	
Year	1988		1996		1989		1995		
Reference TSFC	$1.69 \cdot 10^{-5}$		$1.54 \cdot 10^{-5}$		$1.65 \cdot 10^{-5}$		$1.54 \cdot 10^{-5}$		
Authors	<b>Mattingly 1996</b>	-	$1.58 \cdot 10^{-5}$	2.6	-	-	$1.58 \cdot 10^{-5}$	2.6	$f(M)$
	<b>Svoboda 2000</b>	$1.83 \cdot 10^{-5}$	8.64	$1.82 \cdot 10^{-5}$	18.1	$1.84 \cdot 10^{-5}$	10.5	$1.82 \cdot 10^{-5}$	$f(T_{To})$
	<b>Sforza 2011</b>	$1.98 \cdot 10^{-5}$	17.3	$1.98 \cdot 10^{-5}$	28.7	$1.98 \cdot 10^{-5}$	20.4	$1.98 \cdot 10^{-5}$	$f(T_{CR})$
	<b>Howe 2000</b>	$1.59 \cdot 10^{-5}$	5.44	$1.60 \cdot 10^{-5}$	3.95	$1.60 \cdot 10^{-5}$	2.54	$1.61 \cdot 10^{-5}$	$f(BPR, M)$
	<b>Herrmann 2010</b>	$1.62 \cdot 10^{-5}$	3.7	$1.63 \cdot 10^{-5}$	6.16	$1.67 \cdot 10^{-5}$	1.75	$1.72 \cdot 10^{-5}$	$f(BPR, M...)$

The method best fulfilling the criteria was the one proposed by **Herrmann 2010**. Herrmann’s model is based on a model from **Torenbeek 1986** that was updated and improved. The necessary input parameters for conducting the calculations are:

- By-Pass Ratio (*BPR*)
- Overall Pressure Ratio (*OAPR*)
- Turbine Entry Temperature (*TET*)
- Inlet pressure loss ratio ( $\Delta p/p$ )
- Engine component efficiencies: ventilator, compressor, turbine, nozzle

The author provides equations for all necessary inputs, based on data from engine manufacturers (Rolls Royce). Figure 2.13 explains the author’s model.

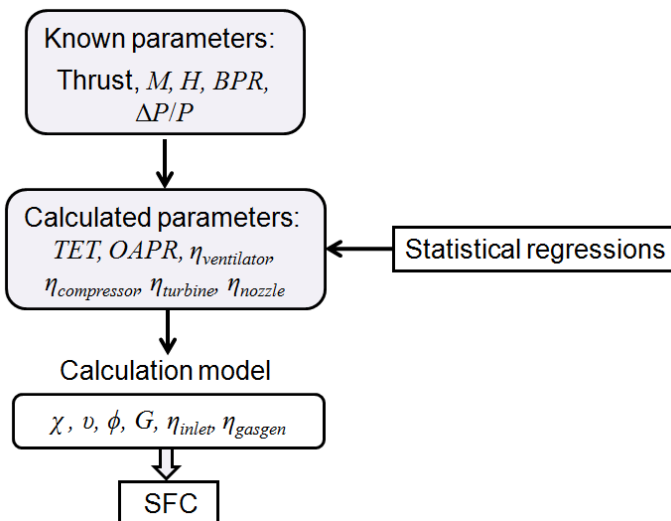

**Fig. 2.13** TSFC model based on **Torenbeek 1986** and **Herrmann 2010**

The TSFC model is given by Equation (2.72). For the calculation, the gas generator function,  $G$ , in Equation (2.73), needs to be determined, for which the set of Equations (2.74) is required. The equations are the result of updated statistical regressions. The Turbine Entry Temperature (TET) equation was not published by the author, due to confidentiality reasons. The missing term (1520 K) was found based on own research and reasoning.

$$SFC = \frac{0.697 \cdot \sqrt{\frac{T(H)}{T_0}} \cdot \left(\phi - \vartheta - \frac{\chi}{\eta_{compressor}}\right)}{\sqrt{5 \cdot \eta_{nozzle} \cdot (1 + \eta_{fan} \cdot \eta_{turbine} \cdot BPR) \cdot (G + 0.2 \cdot M^2 \cdot BPR) \cdot \frac{\eta_{compressor}}{\eta_{fan} \cdot \eta_{turbine}}} - M \cdot (1 + BPR)} \quad (2.71)$$

$$G = \left(\phi - \frac{\chi}{\eta_{compressor}}\right) \cdot \left[1 - \frac{1.01}{\eta_{gasgen}^{\frac{\gamma-1}{\gamma}} \cdot (\chi + \vartheta) \cdot \left(1 - \frac{\chi}{\phi \cdot \eta_{compressor} \cdot \eta_{turbine}}\right)}\right];$$

$$\vartheta = 1 + \frac{\gamma-1}{2} \cdot M^2; \quad \phi = TET/T(H); \quad \chi = \vartheta \cdot \left(OAPR^{\frac{\gamma-1}{\gamma}} - 1\right); \quad \eta_{gasgen} = 1 - \frac{0.7M^2(1-\eta_{inlet})}{1+0.2M^2} \quad (2.72)$$

$$TET = \frac{-8000 \text{ K} \cdot \text{kN}}{T_{TO}} + 1520 \text{ K}$$

$$OAPR = 2.66785 \cdot 10^{-5} \text{ 1/kN} \cdot T_{TO} + 3.5168 \cdot BPR + 0.0556628$$

$$\eta_{compressor} = \frac{-2}{2 + T_{TO}} - \frac{0.1171127}{0.1171127 + BPR} - M \cdot 0.0541 + 0.9407245$$

$$\eta_{turbine} = \frac{-3.403}{3.403 + T_{TO}} + 1.04826 - M \cdot 0.15533$$

$$\eta_{inlet} = 1 - (1.3 + 0.25 \text{ BPR}) \cdot \frac{\Delta p}{p} \quad (2.73)$$

$$\eta_{fan} = \frac{-5.978}{5.978 + T_{TO}} - M \cdot 0.1479 - \frac{0.133498}{0.133498 + BPR} + 1.05489$$

$$\eta_{nozzle} = \frac{-2.0319}{2.0319 + T_{TO}} + 1.00764 - M \cdot 0.009868$$

$T(H)$  is the temperature at altitude,  $T_0 = 288 \text{ K}$ ,  $T_{TO}$  is the take-off thrust of one engine and  $\Delta p/p \approx 0.02$  is the inlet pressure loss. Efficiencies are only valid for  $T_{TO} > 80 \text{ kN}$ .

When implementing this model for the selected engines, the deviations from reference are good. Although this model was built on a large engine database, it seems that it fits better for older engines. A summary of the evaluation of Herrmann's method is given in Table 2.18.

**Table 2.18** Evaluation of the Herrmann model

Engine	$SFC_{CR}$ [kg/N/s]	delta	OAPR	TET	$\eta_{inlet}$	$\eta_{fan}$	$\eta_{compressor}$	$\eta_{turbine}$	$\eta_{nozzle}$
<b>CFM 56 5A1</b>	1.62E-05	<b>-3.73%</b>	24.1	1519.9	0.944	0.869	0.862	0.900	0.982
<b>CFM 56 5B4</b>	1.63E-05	<b>6.16%</b>	23.3	1519.9	0.945	0.872	0.863	0.902	0.983
<b>V2500 A1</b>	1.67E-05	<b>1.75%</b>	22.0	1519.9	0.947	0.867	0.860	0.900	0.982
<b>V2527 A5</b>	1.71E-05	<b>11.68%</b>	20.1	1519.9	0.947	0.868	0.859	0.902	0.983
Engine			$T(H)$	$\phi$	$\gamma$	$\nu$	$\chi$	$\eta_{gasgen}$	$G$
<b>CFM 56 5A1</b>			216.65	7.016	1.4	1.115	1.65	0.979	2.41
<b>CFM 56 5B4</b>			216.65	7.016	1.4	1.115	1.63	0.980	2.42
<b>V2500 A1</b>			216.65	7.016	1.4	1.115	1.58	0.980	2.43
<b>V2527 A5</b>			216.65	7.016	1.4	1.115	1.51	0.980	2.44

Figure 2.14 shows the behavior of the SFC with BPR, based on Herrmann's model. The plot is obtained in OPerA for the A320 aircraft. For this aircraft, there is an optimal BPR, for which the SFC is minimum.

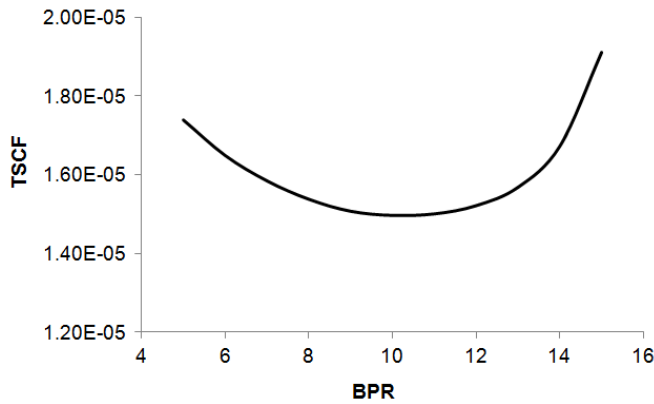

**Fig. 2.14** TSFC as a function of BPR for the A320 aircraft obtained with Herrmann's model in OPerA

## 2.2.8 Estimating Landing Gear Parameters and Mass

### Main and Nose Landing Gear Lengths

Already in the Preliminary Design, the landing gear geometry must ensure:

- 1.) Tail strike prevention,
- 2.) Engine ground clearance,
- 3.) Wing tip ground clearance.

The estimation of main and nose landing gear lengths can be performed based on the aircraft geometry. Geometrical parameters can be defined as in Figure 2.15 ( $b_{KB}$  is the keel beam span).

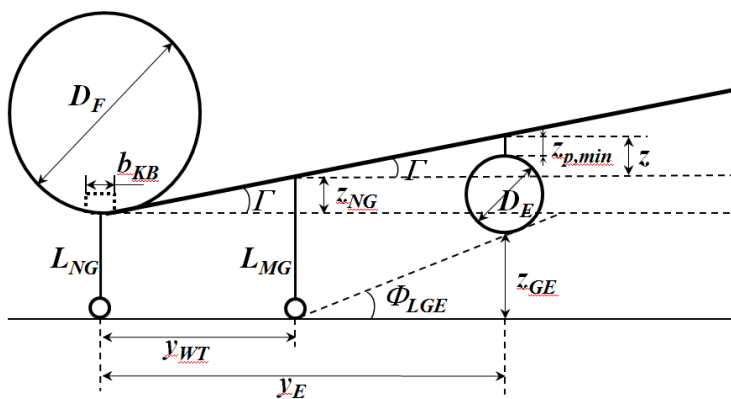

**Fig. 2.15** Parameters for estimating landing gear lengths

According to Figure 2.15, the following set of relations can be written:

$$\begin{aligned}
(1) \quad & L_{MG} = z_{GE} + D_E + z_{P,\min} - z \\
(2) \quad & z_{GE} = \tan(\Phi_{LGE}) \cdot (y_E - y_{WT}); \quad z_{GE} \geq 17'' \\
(3) \quad & z = \tan \Gamma \cdot (y_E - y_{WT}) \\
(4) \quad & L_{MG} = y_{WT} - b_{KB}/2 \\
(5) \quad & L_{NG} = L_{MG} - z_{NG} \\
(6) \quad & z_{NG} = \tan \Gamma \cdot y_{WT}
\end{aligned}
\tag{2.74}$$

$y_E$ , i.e. the position of the engine on the wing, can be, at this stage, statistically determined. For aircraft with two engines (one on each wing) the value  $y_E = 0.33$  can be taken; for aircraft with four engines (two on each wing), the first engine is statistically at  $y_{E,1} = 0.39$  and the second engine at  $y_{E,2} = 0.67$  (statistic was performed on 25 twin engines commercial aircraft and on 12 four engines commercial aircraft).

From relations (1) and (4) in (2.74) the key parameter  $y_{WT}$  (WT stands for Wheel Track) can be determined, with which all the rest of the parameters in (2.74) can be calculated:

$$y_{WT} = \frac{y_E (\tan \Gamma - \tan \Phi_{LGE}) - \frac{b_{KB}}{2} - D_E - z_{P,\min}}{\tan \Gamma - \tan \Phi_{LGE} - 1}
\tag{2.75}$$

The resulting lengths have to be iterated until all the above three conditions are met.

1.) *Tail strike prevention.* Tail strike can occur in two points, either point *A* or point *B*, depending on the landing gear length (and the tail form), as shown in Figure 2.16.

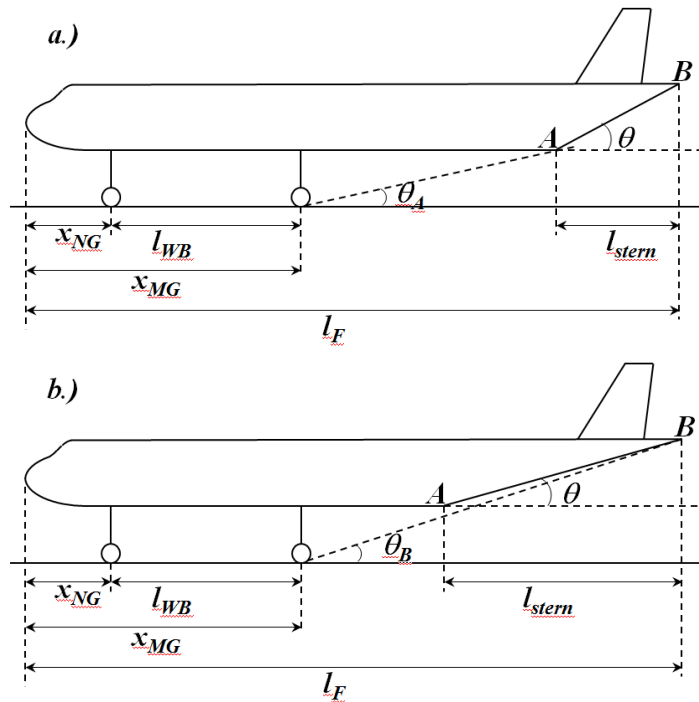

**Fig. 2.16** Tail strike may occur in two points: either in point *A* – Figure a.) or in point *B* – Figure b.)

Depending on the point in which the tail strike may occur, the condition to be met is:

$$\tan \theta_A = \frac{L_{MG,short}}{l_F - l_{stern} - x_{MG}}$$

or

$$\tan \theta_B = \frac{L_{MG,long} + d_F}{l_F - x_{MG}} \quad (2.76)$$

No consideration is given here to the compression of the landing gear. The  $x_{MG}$  can be calculated as the sum between  $x_{NG}$  and  $l_{WB}$ , which is the length of the wheel base:

$$x_{MG} = x_{NG} + l_{WB} \quad (2.77)$$

Both  $x_{NG}$  and  $l_{WB}$  can be statistically determined:

$$x_{NG} = (l_F - l_{stern}) \frac{x_{NG}}{l_F - l_{stern}}$$

$$x_{WB} = \frac{(l_F - l_{stern})}{\left( \frac{l_F - l_{stern}}{x_{WB}} \right)}$$

with statistical factors having the values:  $\frac{x_{NG}}{l_F - l_{stern}} = 0.19$  and  $\frac{l_F - l_{stern}}{x_{WB}} = 2.10$ . Fuselage and stern lengths are determined in the Section 3.

The minimum angle among  $\theta_A$  and  $\theta_B$  needs to be greater than the incidence angle,  $\alpha$ . If this condition is not fulfilled, then the landing gear lengths need to be recalculated with the equation corresponding to the smaller angle between  $\theta_A$  and  $\theta_B$ .

- 2.) *Engine ground clearance.* In Figure 2.15 the engine ground clearance is the distance  $z_{GE}$  between engine nacelle and ground. Industry practice sets this distance to a value of at least 17 inches (0.43 meters),  $z_{GE} \geq 17"$  (**Airbus 2011, Ostrower 2011**). Both Boeing and Airbus have initiated a modernization program for the B737 and A320 families that include modern engine replacements. While the engine diameter increased, (for achieving higher BPR and hence less SFC), the landing gear length needed to be long enough to ensure sufficient ground clearance.
- 3.) *Wing tip ground clearance.* To prevent lateral tip, the bank angle should be between  $6^\circ$  and  $8^\circ$ ,  $\Phi_{LGE} = 6 \dots 8^\circ$ . According to industry practice (Airbus), the minimum bank angle is  $7^\circ$  (**Trahmer 2008**).

For ensuring the fulfilling of all three conditions, in OPerA, the calculation of the main and nose landing gear lengths are iterative. *Iteration 1* is calculating  $L_{MG}$  and  $L_{NG}$  from (2.74), more precisely relations (4) and (5), with the aid of (2.75). If the engine ground clearance



condition is not met, i.e. if  $z_{GE} < 17''$ , then  $L_{MG}$  and  $L_{NG}$  are recalculated with  $z_{GE} = 17''$ . This is *Iteration 2*. Further, to ensure tail strike prevention, the terms required in (2.76) are calculated. The smallest between the two  $\theta_A$  and  $\theta_B$  angles, called  $\theta_{critical}$ , is compared to the incidence angle,  $\alpha$ . If  $\theta_{critical} > \alpha$ , then an *Iteration 3* would be necessary.

In OPerA a last, additional check is performed, i.e. whether the nose landing gear fits in the fuselage bay or not. For that, the statistical parameter  $x_{NG} / L_{NG} = 3.10$  is used. If the nose landing gear does not fit, then all input parameters should be revised and calculation should restart from *Iteration 1*.

### Main and Nose Landing Gear Mass

An important criterion for selecting an adequate mass estimation of the landing gear, was the *dependency of the mass on landing gear lengths*. The landing gear length is, for example, sensible at BPR modification. In case the optimization, striving towards higher fuel efficiency, delivers a high BPR engine, with a correspondingly higher engine diameter, then, following the relations in (2.74), a higher landing gear length is required. The landing gear mass should be correspondingly higher. Since the intention was to build a tool able to generate Aircraft Design statements and results based on the relations between main aircraft parameters, during preliminary design, other equations, which required more detailed input data for calculating landing gear masses, were ruled out. Hence, another criterion was the *dependency of the mass on general landing gear parameters*, determinable during landing gear conceptual design. Or, in other words, a limited amount of input data should be required for estimating the landing gear mass.

Table 2.19 underlines some of the details of the overviewed equations.

**Table 2.19** Evaluation of available landing gear mass estimation methods

Author and reference	Criteria	Required amount of input data (- high, + low)	Dependency on landing gear length	Ranking
<b>Raymer 1999</b>		+	Yes	1
<b>Torenbeek 1986</b>		+++	No	3
<b>Roskam 1989</b>		+++	No	3
<b>Markwardt 1998</b>		+++	No	3
<b>LTH 2008</b>		+	Yes	1
<b>Chai 1996</b>		---	No	5
Boeing in <b>Fernandez 2001</b>		++	No	4
<b>Schulz 2004a, Schulz 2004b</b>		--	Yes	2

**Raymer 1999** and **LTH 2008** had similar approaches and both fulfilled the criteria in the same way. To rule out one of them, an additional criterion was taken into account – *the accuracy* of each of the two methods. According to **Fernandez 2001**, Raymer’s equation is quite inaccurate for A320, A330 and A340 aircraft (with deviations up to 52 %). LTH’s

method is more accurate, with deviations of about 10 %. The **LTH 2008** equation is hence selected for implementation in OPerA:

$$\begin{aligned} m_{LG,main} &= 5.496 \cdot V_{FL}^{0.172} \cdot V_S^{0.317} \cdot m_{ML}^{0.942} \cdot L_{MG}^{0.152} \cdot I_{WB}^{0.234} \cdot I_{SPRING,main}^{0.101} \cdot p_T^{-0.068} \\ m_{LG,nose} &= 5.538 \cdot V_{FL}^{0.179} \cdot V_S^{0.128} \cdot m_{ML}^{0.779} \cdot L_{NG}^{0.276} \cdot I_{SPRING,nose}^{-0.1} \cdot p_T^{-0.161} \end{aligned} \quad (2.78)$$

where:

$V_{FL}$	Approach speed for flapless landing
$V_S$	Safe landing rate of sink
$m_{ML}$	Maximum landing mass
$I_{SPRING}$	Spring deflection
$p_T$	tire pressure

The equation is a non-linear regression, resulted from tested aircraft (in **LTH 2008**).

An estimation of the approach speed for flapless landing is required. This can be approximated as such:

$$\begin{aligned} V_{FL} &= V_{APP} \cdot \sqrt{\frac{C_{L,APP}}{C_{L,FL}}} \quad \text{with} \\ C_{L,APP} &= \frac{C_{L,max,L,swept}}{1.3^2} \\ C_{L,FL} &= \frac{C_{L,max,L,swept} - \Delta C_L \cos \varphi_{25}}{1.3^2} \end{aligned} \quad (2.79)$$

The term  $\Delta C_L$  can take a value of 1.4.

## 2.2.9 Estimating other Aircraft Parameters

Other parameters necessary for Conceptual Design were given attention either by performing new statistics, or by generating new approaches.

### Dihedral Angle Estimation

For using the set of relations (2.74) given in the previous section, the dihedral angle is required. For roll stability and maneuverability each aircraft needs a certain dihedral. During Preliminary Design stage, the dihedral can be either set as a constant value, or, if a more accurate approach is preferred, a suitable estimation method should be employed.

Based on a statistical analysis performed on a number of 41 different aircraft, a method for initial estimation of the dihedral is proposed:

$$\Gamma = \frac{\partial \Gamma}{\partial k_{Z,W}} \cdot k_{Z,W} + \frac{\partial \Gamma}{\partial \varphi_{25}} \cdot \varphi_{25} + \Gamma_0 \quad (2.80)$$

The  $k_{Z,W}$  accounts for the wing position (this convention was used also in **Goldberg 2011**):

$k_{Z,W} = 0.0$ , for low wing aircraft

$k_{Z,W} = 0.5$ , for mid-wing aircraft

$k_{Z,W} = 1.0$  for high-wing aircraft

Table 2.20 presents the results of the statistical analysis: values of the factors in (2.80) that show the variation of the dihedral with the position of the wing and with the sweep angle are given in the left column. For comparison purposes, Raymer's values are given in the right column (**Raymer 1999**).

	Own	Raymer
$\frac{\partial \Gamma}{\partial k_{Z,W}}$	- 7.46°	- 7°
$\frac{\partial \Gamma}{\partial \varphi_{25}}$	- 0.115	- 0.1
$\Gamma_0$	6.91°	6°

Resulting statements of this research are:

- Moving the wing position from High to Low, produces the effect of 7.5° of dihedral.
- 8.7° of sweep produce the effect of 1° of dihedral.
- For a low and unswept wing, the value of 6.9° of dihedral should be used.

The 41 aircraft included in the statistic have values of dihedral within the following ranges:

**Table 2.21** Gamma ranges for swept and unswept wing aircraft from own statistic

Own estimation of $\Gamma$ ranges	$k_{Z,W}$		
	0	0.5	1
Unswept wing	3°...7°	-	- 2°...2°
Swept wing	2.5°...6.5°	- 5°...0°	- 7°...0°

For comparison, **Raymer 1999** found:

**Table 2.22** Gamma ranges for swept and unswept wing aircraft from **Raymer 1999**

Raymer estimation of $\Gamma$ ranges	$k_{Z,W}$		
	0	0.5	1
Unswept wing	5°...7°	-	- 2°...2°
Swept wing	3°...7°	-	- 5°...- 2°

To conclude:

- The variations in dihedral are a little higher than reported by **Raymer 1999**.
- This more detailed study has generally confirmed the rule of thumb extracted from literature.

### Changes in Load Factor due to Gusts

The way aircraft respond to changes in load factor due to gusts, reflects on passenger comfort. The measure of passenger comfort becomes of interest later in this work (more precisely in Sections 8 and 9), when Aircraft Design Optimization will be performed also by taking into account the effect of certain parameters that may bring an Added Value to the design / airline. Since this section deals with the theoretical improvements or contributions brought to the field, it was found adequate to speak already here of the way the effect of gusts may be quantified at Preliminary Design level.

For CS 23 aircraft a method is given by the certification authorities for quantifying these changes, noted with  $\Delta n$  (CS 23.335, CS 23.341 in **CS 23**). For aircraft from CS 25 a similar approach is used, but a higher degree of accuracy is required by the authorities. This degree of accuracy in calculations can only be achieved during detail design. For Preliminary Design the method for CS23 aircraft is suitable also for CS25 aircraft. Below, the results from adapting this method for CS 25 aircraft are given:

$$\Delta n = \frac{\rho K U_{DE} V_{CR} C_{L,\alpha}}{2(m_{MTOG} / S_W)} , \quad (2.81)$$

with:

$$K = \frac{0.88\mu}{5.3 + \mu} \quad (2.82)$$

$$\mu = \frac{2(m_{MTOG} / S_W)}{\rho c_{MAC} C_{L,\alpha} g}$$



$$\begin{aligned} -1200\text{ft/s} \cdot U_{DE} + 80000\text{ft} &= H \\ -1200\text{m/s} \cdot U_{DE} + 24384\text{m} &= H , \end{aligned} \quad (2.83)$$

$$U_{DE} = \frac{24384\text{m} - H}{1200\text{m/s}}$$

and:

$$C_{L,\alpha} = \frac{2\pi A}{2 + \sqrt{A^2 \cdot (1 + \tan^2 \varphi_{50} - M^2)} + 4} \quad (2.84)$$

In Equation (2.82)  $K$  is called gust alleviation factor, and  $\mu$  is a mass ratio used to calculate it. In Equation (2.83)  $U_{DE}$  is the gust velocity, and in Equation (2.84)  $C_{L,\alpha}$  is the lift curve slope (from **Hoak 1978**).

### Thickness Ratio and Wave Drag

In OPerA an equation was required also for estimating the thickness ratio. It was found that the equation with the best potential in matching statistical data was given by **Scholz 2005**. In this paper the authors investigate a number of 12 equations for calculating the average thickness ratio and test them on a number of 29 selected aircraft. The authors conclude that the best equation is a nonlinear regression, obtained by adapting free parameters to the aircraft database. Since the authors ruled out most of the existing methods for estimating the thickness ratio<sup>1</sup>, it was decided to implement and test their proposal. After a better understanding and analysis of their results (available at hand), it was decided to eliminate those free parameters that didn't deliver a logical behavior and correct accordingly their non-linear regression. The result is relation (2.85):

$$t/c = k_t \cdot M_{DD,eff}^t \cdot k_M \quad (2.85)$$

Equation (2.85) yielded very good data matching. Statistical data was matched through the factors:

$k_t$	0.100
$t$	- 0.389
$k_M$	1.057 for supercritical airfoils
	1.004 for peaky airfoils
	1.000 for conventional airfoils

In Equation (2.86) the effective drag divergence Mach number is used, which can be approximated with:

$$M_{DD,eff} = M_{DD} \sqrt{\cos \varphi_{25}} \quad (2.86)$$

Although Equation (2.85) proved to be very accurate, when implemented in OPerA, the optimization delivered a quite small sweep angle. Since the sweep effect given by (2.85) was not enough to ensure the balance between parameters and their repercussions, an equation was sought that included a higher sweep effect.

**Mason 2006** gives an equation for thickness ratio based on D. Korn that matches quite well in practice:

$$M_{DD} = \frac{\kappa_A}{\cos \varphi_{25}} - \frac{(t/c)}{\cos^2 \varphi_{25}} - \frac{C_L}{10 \cos^3 \varphi_{25}} \quad (2.87)$$

---

<sup>1</sup> **Torenbeek 1986** offered the second best solution; the advantage of his approach is that it is based on aerodynamic considerations and not on pure mathematical approach.

In (2.87)  $M_{DD}$  is the drag divergence Mach number and  $\kappa_A$  is an airfoil technology factor. For NACA 6 series profiles  $\kappa_A = 0.87$ , while for supercritical airfoils the value is  $\kappa_A = 0.95$ .

In OPerA, this equation has a better sweep effect, and even though its accuracy was less than the corrected Scholz model (Scholz 2005), which with this respect keeps its superiority, it yielded better results in the tool frame, contributing to a balanced compendium of equations.

### Other Statistical Factors

For calculating a collection of basic parameters, further to be used for the Conceptual Design and Optimization of an aircraft in OPerA, many statistical factors were introduced. Hence, many up-to-date statistics are incorporated in OPerA in the form of “ $k$ ” factors, some of which are listed in Table 2.23.

**Table 2.23** Selected statistical factors and equations determined for integration in OPerA

Factor	Usage	Value	Equation
$k_{M_{DD}H,V}$	Factor for determining the drag divergence Mach number of the horizontal, respectively vertical tail, $M_{DD,H}$ and $M_{DD,V}$ having the $M_{DD}$ for wing	0.05	$M_{DD,H,V} = k_{M_{DD}H,V} + M_{DD}$
$k_{A,H}$	Factor for determining the aspect ratio of the horizontal, respectively vertical tail from the wing aspect ratio	0.50	$A_H = A \cdot (1 - k_{A,H})$
$k_{A,V}$	Factor for determining the aspect ratio of the horizontal, respectively vertical tail from the wing aspect ratio	0.81	$A_V = A \cdot (1 - k_{A,V})$
$\frac{z_H}{b_V}$	Factor indicating the position of the vertical tail:		$A_V = -0.8029 \cdot \frac{z_H}{b_V} + 1.6576$
	Conventional	0	
	T-Tail	1	
	Cruciform	0.56	
$k_{\phi,H}$	Factor for determining the sweep angle of the horizontal tail, respectively vertical tail from the wing sweep angle	5°	$\phi_{25,H} = \phi_{25} + k_{\phi,H}$
$k_{\phi,V}$	Factor for determining the sweep angle of the horizontal tail, respectively vertical tail from the wing sweep angle	0.44	$\phi_{25,V} = \phi_{25} \cdot (1 + k_{\phi,V})$
$k_{(t/c)H}$	Factor for determining the horizontal tail thickness ratio from the wing thickness ratio	0.10	$(t/c)_H = (t/c) \cdot (1 - k_{(t/c)H})$
$k_{\lambda,H}$	Factor for determining the horizontal tail, respectively vertical tail taper ratio from the wing taper ratio	0.32	$\lambda_H = \lambda \cdot (1 + k_{\lambda,H})$
$k_{\lambda,V}$	Factor for determining the horizontal tail, respectively vertical tail taper ratio from the wing taper ratio	0.38	$\lambda_V = \lambda \cdot (1 + k_{\lambda,V})$
$k_{l,H,V}$	Factor for determining the lever arm of the horizontal, respectively vertical tail from fuselage length	0.50	$l_{H,V} = l_F \cdot k_{l,H,V}$
$k_{D,N}$	Factors for determining the nacelle diameter, respectively length from engine diameter, respectively length	0.20	$D_N = D_E + k_{D,N}$
$k_{l,N}$	Factors for determining the nacelle diameter, respectively length from engine diameter, respectively length	0.82	$l_N = l_E + k_{l,N}$
$\tau$	Statistical values for relative thickness ratio of the wing:		$\tau = \frac{(t/c)_t}{(t/c)_r}$
	Conventional	0.888	
	Peaky	0.816	
	Supercritical	0.774	

## 2.3 Identifying Key Design Variables for Optimization

Preliminary Sizing and Conceptual Design parameters that are set free during the optimization are key parameters that crucially influence the design. Initial design space exploration and optimization is performed by varying *design parameters*. Ultimately also *requirements* are set free. Table 2.24 lists all Preliminary Sizing and Conceptual Design optimization variables (additional cabin parameters, that are also varied, are mentioned in Section 3.3).

**Table 2.24** Key Preliminary Sizing variable for optimization

Parameter		Type
Maximum lift coefficient, landing, for 0° sweep angle	$C_{LmaxL,unswept}$	design variable
Maximum lift coefficient, take-off, for 0° sweep angle	$C_{LmaxTO,unswept}$	design variable
Sweep angle	$\varphi_{25}$	design variable
Taper ratio	$\lambda$	design variable
Relative distance between engine and wing	$z_P / D_N$	design variable
By-Pass ratio	$BPR$	design variable
Maximum landing mass to maximum take-off mass ratio	$m_{ML} / m_{MTO}$	design variable
Number of engines	$n_E$	design variable
Aspect ratio	$A$	design variable, but limited to airport requirements
Landing field length	$S_{LFL}$	requirement
Take-off field length	$S_{TOFL}$	requirement
Cruise Mach number	$M_{CR}$	requirement

# 3 Methodology for Cabin and Fuselage Preliminary Sizing and Conceptual Design

## 3.1 Sizing from Requirements and Statistics

The Conceptual Design of the fuselage is bounded by a wide set of requirements coming either from the manufacturer, from the operator, from the airport or from the regulator (EASA for Europe or FAA for USA). *An airline* is interested to carry as much payload as possible, while ensuring enough passenger comfort. Other requirements are reduced maintenance costs or enough operational flexibility. *An airport* would require an aircraft with feasible ground operation. In this context, *the manufacturer* aims to build a flexible, cost efficient, performance based aircraft, while accounting for all the rest of requirements.

However, from the point of view of Preliminary Sizing and Conceptual Design, the basic requirement is the *payload*, given by number of passengers and baggage and cargo mass. Based on these design requirements, once a configuration is selected, several other estimations can be launched (a more detailed description of Preliminary Design of cabin can be found in **Scholz 1999** or **Niță 2010**):

- Estimation of an optimal number of seats abreast as a function of the number of passengers;
- Estimation of the cabin width (based on seat width, number of aisles and aisle width);
- Estimation of the cabin length (by considering the average seat pitch, the required cabin floor area, or by considering a preliminary cabin layout);
- Estimation of the fuselage length (by using a value for the slenderness parameter or by summing the cockpit length, the tail length and the cabin length);
- Verification of the preliminary fuselage geometry ensuring sufficient cargo volume to accommodate check-in baggage and cargo.

The traditional approach to perform the above estimations is using statistics. This classic methodology was refined, either by using updated statistical data, or by implementing new approaches.



## 3.2 Refinement of the Cabin Sizing and Conceptual Design Methodology

### 3.2.1 Estimating Basic Parameters

#### Inner and Outer Fuselage Diameter

The inner fuselage diameter can be obtained as the sum of major parameters describing the upper fuselage cross-section: seat width, armrest width, aisle width, sidewall clearance:

$$d_{F,i} = n_{SA} \cdot w_{seat} + (n_{SA} + n_{aisle} + 1) \cdot w_{armrest} + n_{aisle} w_{aisle} + 2s_{clearance} \quad (3.1)$$

The outer diameter can be calculated from the inner diameter and the values of skin thickness, stringer height, frame height, insulation and lining panel thickness. It is

$$\begin{aligned} d_{F,o} &= d_{F,i} + w_t \\ d_{F,o} &= d_{F,i} + t_{skin} + h_{frame} + h_{stringer} + t_{isolation} + t_{liningpanel} \end{aligned} \quad (3.2)$$

where  $w_t$  represents the wall thickness. However, in practice it might be difficult to obtain these values. As a first information, Table 3.1 provides data from Airbus.

Another approach used by **Markwardt 1998** is to calculate the difference between the inner and outer diameter from a statistical analysis, from which an empirical equation can be derived:

$$d_{F,o} = 1.045d_{F,i} + 0.084 \text{ m} \quad (3.3)$$

#### Number of Seats Abreast

$n_{SA}$  is a parameter that greatly reflects on the degree of passenger comfort. **Raymer 1999** gives the relation:

$$n_{SA} = 0.45\sqrt{n_{PAX}} \quad (3.4)$$

The coefficient in Equation (3.4) has the significance of  $\sqrt{n_{SA}/n_r}$ . The background of this factor is simple:  $n_{PAX} = n_{SA} \cdot n_r = n_{SA}^2 \cdot \frac{n_r}{n_{SA}} \Rightarrow n_{SA} = \sqrt{\frac{n_{SA}}{n_r}} \cdot \sqrt{n_{PAX}}$ . Own statistic delivered the value 0.469 for this coefficient, which confirms Raymer's value in (3.4).

Figure 3.1 presents a statistical diagram showing the relation between the number of passengers and the slenderness ratio, for different aircraft with number of seats abreast

ranging from 3 to 9. For a given number of passengers, the number of seats abreast can be chosen from the diagram so that a suitable slenderness ratio results<sup>1</sup>.

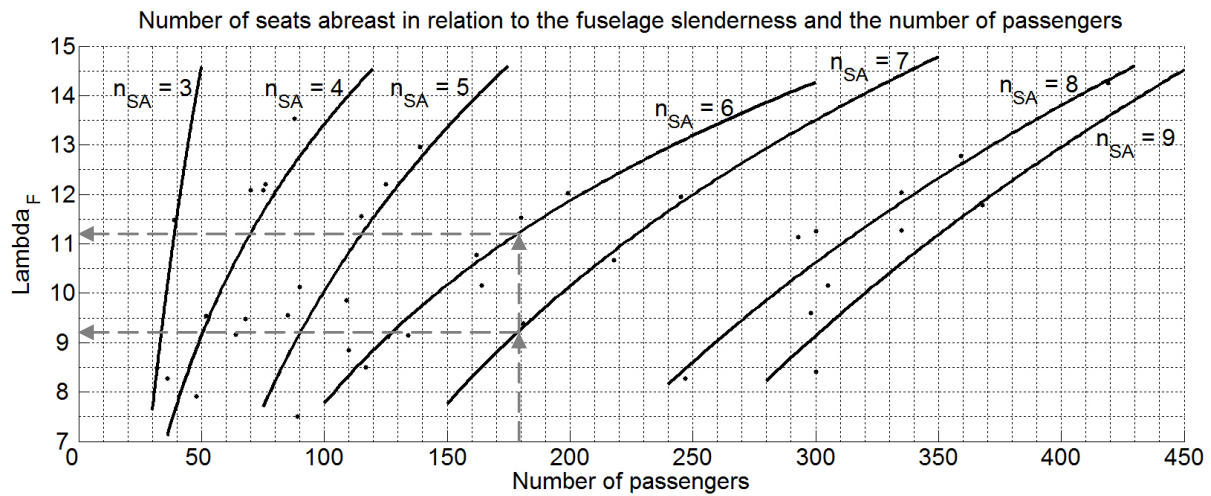

**Fig. 3.1** Diagram showing, for selected aircraft, the relation between the number of passengers and fuselage slenderness,  $\lambda_F$ , with number of seats abreast as parameter (Niță 2010)

### Aisle Width

Aisles have to be wide enough to allow safe evacuation. Minimum aisle width is given in CS 25.815(CS 25).

**Table 3.1** A list of cabin parameters and their typical values (Scholz 2008)

Parameter	Value
Sidewall clearance	0.02 m (at shoulder)
Floor beam height	80-250 mm
Floor panel	10 mm
Seat rail height	5-65 mm
Cargo hold ceiling	10 mm
<b>Floor thickness</b>	<b>100-300 mm</b>
Skin thickness	2-4 mm
Stringer height	30-40 mm
Frame height	50-100 mm
Isolation	25-35 mm
Lining panel	5-10 mm
<b>Outer contour to cabin lining</b>	<b>100-200 mm</b>
Seat width (double)	44 in – Economy 54 in – Business 58 in – First
Seat width (cushion)	19 in
Armrest width	2 in

### Cabin Length

A first and simple approximation of the cabin length is:

$$l_{cabin} = n_r \cdot k_{cabin} = \frac{n_{pax}}{n_{SA}} \cdot k_{cabin} \quad (3.5)$$

<sup>1</sup> It's important to keep in mind that for a number of seats abreast larger than six the certification regulations require an additional aisle (according to CS 25.815 in CS 25).

where  $k_{cabin}$  has the significance of an average seat pitch taking into account the surface of additional cabin items (such as galley, lavatories, ...) and  $n_r$  is the number of rows. The value of  $k_{cabin}$  lies between 1.0 m and 1.1 m, according to **Scholz 1999**. A statistic performed on 23 selected aircraft shows that wide bodies have an average  $k_{cabin}$  of 1.17 m while single aisle aircraft have an average  $k_{cabin}$  of 1.08 m. For a high density layout, (typical for low-cost carriers) for which the seat pitch is smaller, the factor is smaller than the averages mentioned above (about 0.9 m for 180 passengers).

At a later stage of the cabin definition, the cabin length can be determined from all items in the cabin: seats, lavatories, galleys, crew rest and stowage compartments. The required number of cabin items and their floor area depends on cabin comfort standards (details on comfort standards can be found in references **Schmitt 1988**, **Scholz 1999**, **AFPO 2006**).

In OPerA cabin length is determined from a generic cabin layout, as a sum the lengths given by seats, cross-aisles, lavatories, galleys and additional space (for instance near emergency exits):

$$\begin{aligned}
 L_{seats} &= L_{SP} \cdot n_r \\
 + \\
 L_{cross\ aisles} &= L_{cross\ aisle} \cdot n_{cross\ aisle} \\
 + \\
 L_{lavatories} &= S_{lavatory,tot} / w_{tot} \\
 + \\
 L_{galleys} &= S_{galley,tot} / w_{tot} \\
 + \\
 L_{addition} & \\
 \hline
 &= L_{cabin, generic}
 \end{aligned} \tag{3.6}$$

where:

$$\begin{aligned}
 S_{galley,tot} &= n_{galley} \cdot S_{galley} = n_{trolley} \cdot S_{trolley,average} \\
 S_{trolley,average} &= S_{galley}(n_{trolley}) / n_{trolley} \\
 S_{lavatory,tot} &= n_{lavatory} \cdot S_{lavatory} \\
 w_{tot} &= w_{cabin} - n_{aisle} \cdot w_{aisle}
 \end{aligned} \tag{3.7}$$

*SP* stands for Seat Pitch, *L* stands for Length and *n* stands for number (e.g.  $n_r$  is the number of seat rows).

**Seat Pitch** comes from airline requirements. The length of the **cross aisles** depends on the number of emergency exits, as it is given by the total width of the door plus additional space (see relations (3.6)). More about this can be read in CS 25.807 (**CS 25**). Number of **lavatories and galleys** depends on the number of passengers. According to industry practice (**AFPO 2006**) 1 lavatory is required for every 75 passengers. An average of 1.075 m<sup>2</sup> for a typical lavatory surface is calculated based on typical lavatory layouts.

Galleys are composed of **trolleys**. A typical galley unit contains four trolleys. Each trolley contains on average 28 trays (**AFPO 2006**). Based on references **Markwardt 1998**, **AFPO 2006** and **Schmitt 1988**, values were set for **number of trays per passengers**, depending on the range of the aircraft (results in Table 3.2).

**Table 3.2** Proposal of number of trays per passenger, based on data from references **Markwardt 1998**, **AFPO 2006** and **Schmitt 1988**

Region	No. of trays per passenger
South Atlantic, Fareast, South Africa	2.5
North Atlantic, Nearest	2
Europe	1.5
Germany and neighbors of Germany	1

These assumptions help building a generic galley surface as a function of number of passengers and cabin parameters. This is of importance when optimization is performed, as the effect of cabin parameters needs to be accounted for.

### Fuselage Length

For estimating the fuselage length, for the initial design stage, statistical values can be used. A typical cockpit length is 4 m; the tail can be approximated with  $1.6 \cdot d_{F,equiv}$  (**Schmitt 1988**). The fuselage length becomes:

$$l_F = l_{cabin} + l_{cockpit} + l_{tail} = l_{cabin} + 4 \text{ m} + 1.6 \cdot d_{F,equiv} \quad (3.8)$$

A possible estimation of the relative fuselage nose length (which contains the cockpit) is as a function of maximum operating Mach number,  $M_{MO}$ , as given by Equation (3.9), which was build from data given in **Scholz 2008**. The faster the aircraft flies, the slimmer the nose:

$$\begin{aligned} l_{nose} / d_{F,equiv} &= 44.4048 \cdot M_{MO} - 71.6250 \cdot M_{MO} + 30.4407 \\ M_{MO} &= M_{CR} + 0.04 \end{aligned} \quad (3.9)$$

### 3.2.2 Estimating Baggage and Cargo Volume

The Aircraft Cabin Design method uses simple approximations to generate preliminary results. Nevertheless, these results need to be checked. For the fuselage it is required that the volume of the cargo compartment is able to accommodate all the cargo plus all the baggage that does not fit in the cabin. **Scholz 1999** provides an inequality for this statement:

$$V_{CC} \geq V_C + (V_B - V_{OS}) \quad (3.10)$$

where:

$V_{CC}$  volume of the cargo compartment,

$V_C$  volume of cargo,  
 $V_B$  volume of baggage,  
 $V_{OS}$  volume of overhead stowage.

$$V_{CC} = l_F \cdot k_{CC} \cdot S_{CC} \quad , \quad (3.11)$$

where:

$k_{CC}$  proportion of the fuselage length used for cargo ranging from 0.35 to 0.55,  
 $S_{CC}$  cross-section of the cargo compartment.

Each term can be determined as follows (see Table 3.3 and references **Stefanik 2006**, **Stefanik 2007**):

$$\begin{aligned}
 V_B &= m_B / \rho_B \\
 V_C &= m_C / \rho_C \\
 V_{OS} &= S_{OS,tot} \cdot l_{OS} \quad , \\
 S_{OS,tot} &= n_{OS,lat} \cdot S_{OS,lat} + n_{OS,ce} \cdot S_{OS,ce} \\
 l_{OS} &= k_{OS} \cdot l_{cabin}
 \end{aligned} \quad (3.12)$$

where:

$m_B$  mass of baggage,  
 $m_C$  mass of cargo,  
 $\rho_B$  density of baggage,  
 $\rho_C$  density of cargo,  
 $S_{OS,tot}$  total cross-section of the overhead stowages calculated as a sum of the cross-sections of lateral stowages,  $S_{OS,lat}$ , and central stowages,  $S_{OS,ce}$ ,  
 $n_{OS,lat}$  number of lateral rows of overhead stowages,  
 $n_{OS,ce}$  number of central rows of overhead stowages:  $n_{OS,ce} = n_{aisles} - 1$ ,  
 $l_{OS}$  total length of the overhead stowages (lateral and central),  
 $k_{OS}$  proportion of the cabin length occupied by the overhead stowages.

The baggage must not exceed the maximum load of the overhead stowage, hence density:

$\rho_B < 180 \text{ kg/m}^3$  for single aisle aircraft,  
 $\rho_B < 185 \text{ kg/m}^3$  for twin aisle aircraft.

Assuming that the overhead stowage is not completely loaded (baggage of different types and sizes) the density values supplied by **Torenbeek 1986** can be used for Preliminary Cabin Design:

- Baggage:  $170 \text{ kg/m}^3$ ,
- Cargo:  $160 \text{ kg/m}^3$ .

**Table 3.3** Values for the  $S_{OS,lat}$ ,  $S_{OS,ce}$  and  $k_{OS}$  for selected aircraft with 1 or 2 aisles

$n_{OS}$	Selected Aircraft	$k_{OS}$	$S_{OS,lat}$	$S_{OS,ce}$	$\rho_B$
Number of aisles :1 $n_{OS,lat} = 2$ $n_{OS,ce} = 0$	Single Aisle				
	A 318	0.738	0.208		175.95
	A 319	0.760	0.208		176.32
	A 320	0.771	0.208		175.92
	A 321	0.786	0.208		176.54
	B 737-600	0.687	0.187		192.23
	B 737-600 BB <sup>1</sup>	0.687	0.209		172.32
	B 737-700	0.744	0.187	-	192.00
	B 737-700 BB	0.744	0.209		171.83
	B 737-800	0.697	0.187		192.51
	B 737-800 BB	0.697	0.209		172.24
	B 737-900	-	0.187		192.04
	B 737-900 BB	-	0.209		171.85
	<b>Average</b>	<b>0.723</b>	<b>0.201</b>	-	<b>180.13</b>
Number of aisles :2 $n_{OS,lat} = 2$ $n_{OS,ce} = 1$	Wide Body				
	A 330-200	0.789	0.153	0.230	226.02
	A 330-300	0.808	0.153	0.230	226.11
	A 340-300	0.808	0.153	0.230	226.11
	A 340-500	0.811	0.147	0.230	229.44
	A 340-600	0.804	0.147	0.230	229.56
	A350-800-F <sup>2</sup>	-	0.195	0.320	159.93
	A350-800-P <sup>3</sup>	-	0.195	0.269	182.03
	A350-900-F	-	0.196	0.320	159.40
	A350-900-P	-	0.196	0.269	181.77
	A 380 UD-F <sup>4</sup>	0.744	0.144	0.253	201.15
	A 380 UD-P	0.709	0.108	0.247	233.91
	A 380 MD-F	0.705	0.255	0.253	159.51
	A 380 MD-P	0.672	0.251	0.247	170.43
	B 777-200 ER	0.736	0.227	0.199	161.69
	B 777-300 ER	0.753	0.227	0.199	161.68
	B 787-8	0.749	0.324	0.252	148.60
	B 787-9	0.77	0.324	0.252	148.46
	B 747-400 MD	-	0.262	0.168	174.32
	B 747-8	0.673	0.274	0.210	158.38
	<b>Average</b>	<b>0.751</b>	<b>0.208</b>	<b>0.241</b>	<b>185.01</b>
<b>Overall average</b>	<b>0.737</b>	<b>0.213</b>	-	<b>182.57</b>	

<sup>1</sup> Additionally the BB (i.e. Big Bins) versions of the four B737 aircraft were considered

<sup>2</sup> F stands for Fixed stowages

<sup>3</sup> P stands for Pivoting stowages

<sup>4</sup> Both main deck (MD) and upper deck (UD) were considered

### 3.2.3 Estimating Cargo Compartment Height

In OPerA two methods are at the user's choice to express cargo compartment height,  $h_{cargo}$  as a function of fuselage diameter. Cargo compartment height is necessary for the geometrical description of the lower cross-section. This geometrical description allows (in OPerA) an automatic assessment of which cargo container type (if at all) fits within the cargo compartment. Whether the lower cross-section is able or not to include containers, is of great importance for the airline revenue. This too, is automatically evaluated in OPerA.

The first method is to simply express the cargo compartment height as a function of the fuselage (outer) diameter via a statistical factor, adapted for every class of aircraft (see Table 3.4):

$$h_{cargo} = k_{cargo,height} \cdot d_F \quad . \quad (3.13)$$

**Table 3.4** Statistical factor for cargo compartment height evaluation

Aircraft	$k_{cargo,height}$
Short range	0.200
Medium range	0.290
Long range	0.281

The second method, more accurate, is to express  $h_{cargo}$  as a function of the fuselage radius,  $d_F / 2$ , floor lowering (distance from center of the cross-section to the floor),  $y_{floor,lowering}$ , floor thickness,  $t_{floor}$ , and distance from bottom of the fuselage up to the floor of the cargo compartment,  $y_{bottom}$ :

$$h_{cargo} = d_F / 2 - y_{floor,lowering} - t_{floor} - y_{bottom} \quad . \quad (3.14)$$

Values for these factors can be expressed also relative to  $d_F$  (see Table 3.5). An analysis was performed, on scaled drawings of a set of representative aircraft. It was concluded that for single aisle absolute values give more accurate results, and relative values are more suitable for wide bodies. When looking at many wide body cross-sections, it can be concluded that wide bodies are driven by fuselage width. From a large width, height results more than sufficient. Since the armrest is usually positioned at the maximum fuselage width, then cargo compartments of wide bodies gain more space. For single aisle a trade-off is performed between cargo height and not shifting the armrest more upwards (which is unnecessary for wide bodies).

Both methods are suitable for larger aircraft, while for smaller aircraft a more accurate method, such as the second method is recommended. In OPerA, the user can select one of them, and calculations are automatically performed.

Regarding the width available for containers, it is sufficient to express it as a function of fuselage diameter, via a statistical factor (0.64 for medium range aircraft).

**Table 3.5** Parameters for estimating cargo compartment height

Parameter	Single Aisle	Wide Body	
$y_{floor,lowering}$	0.511	0.316	[m]
$t_{floor}$	0.179	0.232	[m]
$y_{bottom}$	0.225	0.588	[m]
$y_{floor,lowering} / d_F$	0.131	0.054	[-]
$t_{floor} / d_F$	0.045	0.040	[-]
$y_{bottom} / d_F$	0.056	0.101	[-]

### 3.2.4 Estimating the Cargo Hold Accessibility Factor from Sill Height

Sill height and cargo door height are an important measure for working conditions for ground operation. The sill height,  $h_{SH,cargo}$  can be calculated from the nose landing gear length (calculated in Section 2), plus a distance  $k_{SH,cargo}$  in meters (0.26 m for A320-200 aircraft). For assessing the impact of the design on working conditions, it's not the sill height of interest, but an *accessibility factor*,  $k_{SH}$ , which expresses how easy it is for a worker to load and unload baggage. This factor is assessed and described via an empirical diagram in **Brink 1973**. Figure 3.2 shows a diagram as the one in **Brink 1973**, but with slightly different values, concluded upon after discussing with a ground operation worker (**Ottermann 2011**).

The equation describing the diagram is Equation (3.15), which calculates the accessibility factor,  $k_{SH}$  as a function of sill height,  $h_{SH,cargo}$ :

$$\begin{aligned}
 k_{SH} &= \frac{1}{6.9381} \ln \frac{h_{SH,cargo}}{0.001358}, \text{ for } h_{SH,cargo} > 1.4 \text{ m} \\
 k_{SH} &= \frac{1}{12.831} \ln \frac{h_{SH,cargo}}{335924}, \text{ for } h_{SH,cargo} > 0.9 \text{ m} \\
 k_{SH} &= 1, \text{ for } 0.9 < h_{SH,cargo} < 1.4
 \end{aligned}
 \tag{3.15}$$

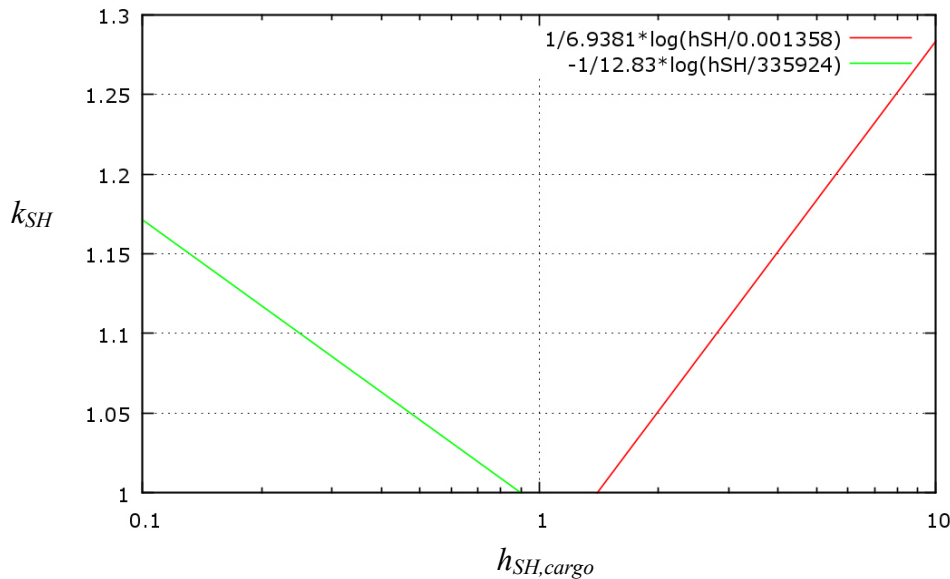

**Fig. 3.2** Accessibility factor as a function of sill height (inspired by **Brink 1973**)

The optimal accessibility factor is 1. On the horizontal axis (see Figure 3.2), this corresponds to a certain range of sill height, precisely between [0.9, 1.4] m. If the distance to ground is lower than 0.9 m or higher than 1.4 m, the working conditions become difficult, and the worker needs either additional assistance, or he needs to sit in a very uncomfortable position. The values 0.9 and 1.4 are slightly different than the values given in **Brink 1973**. The new values were rationally set after interviewing a ground operations worker.

With the constructed Equation (3.15), the accessibility factor can be assessed and accounted for during the optimization process.



### 3.3 Identifying Key Design Variables for Optimization

Cabin parameters determine the fuselage size. As a consequence, they have a major influence on aircraft mass and drag and hence on fuel burn and costs. In addition cabin parameters can also influence boarding time, de-boarding time and even passenger health (**Transport 2010**).

An important role is played by the number of seats abreast,  $n_{SA}$ , which greatly influences the cabin width and length. A secondary role is played by other cabin parameters, that have an impact on comfort standards, rather than the entire aircraft design (such as  $n_{SA}$ ):

- Accessibility factor for cargo working conditions,  $k_{SH}$
- Cargo compartment height,  $h_{cargo}$
- Number of “excuse-me” seats<sup>1</sup>
- Sidewall clearance at armrest
- Overhead bin-volume per passenger
- Aisle height and aisle width
- Armrest width and seat width
- Seat pitch

All these parameters are included in the optimization process, as it will be later shown.

---

<sup>1</sup> "Excuse-me" seats are those seats that require the permission of two passengers to get to the aisle. Window seats are not considered "excuse-me" seats.

## 4 Methodology Calibration and Testing

### 4.1 Iterations in Aircraft Design Methodology

Aircraft Design is characterized by iterations. Implementing the methodology described in Sections 2 and 3 into an *automatic* calculation environment – OPerA, which was designed in Microsoft Excel – requires, implicitly, solving the problem of iterations and ensuring their *convergence*: Whenever an equation refers back to its own cell, directly or indirectly, it creates, in MS Excel, a *circular reference* (or an *iteration loop*).

To solve the circular reference, MS Excel recalculates a worksheet until a specific numeric condition is met: The user can set the maximum number of iterations, or the acceptable amount of change between calculation results. The higher the number of iterations, or the smaller the difference between calculations, the higher the computation time is.

An example of a loop, solved via iterative calculations in Excel is given below:

$C_{D,0}$  is required to calculate  $C_{L,md}$  (lift coefficient at  $E_{max}$ ), based on which  $C_L$  for cruise is calculated, which in turn depends on the value of  $V/V_{md}$  ratio, which moves the cruise line in the matching chart, hence influences the design point. The design point is used to calculate the wing area and take-off thrust, which have a great influence on the entire design, via geometrical parameters or SFC. All these influence the zero-lift drag, and a loop is closed:

$$\boxed{C_{D,0}} \rightarrow C_{L,m} = \sqrt{C_{D,0} \cdot \pi \cdot A \cdot e} \rightarrow C_L / C_{L,md} = 1 / (V / V_{md})^2 \rightarrow DP \rightarrow S_W, T_{TO} \rightarrow S_{wet}, SFC, \text{ etc} \rightarrow \boxed{C_{D,0}}.$$

Other simpler examples that may be found in OPerA (as Aircraft Design model), are:

- The *SFC* calculation model requires take-off thrust as an input; take-off thrust is a result that uses *SFC* values.
- Estimation of fuselage weight requires the input of dive speed,  $V_D$  that depends on speed of sound, which is a function of the cruise altitude. Cruise altitude represents an output of cruise calculation.

OPerA contains at least 15 iteration loops among the 15 calculation sheets. This is a difficult task for MS Excel. Failing to solve the iterations leads to stability problems. Caution measures are in this case required.

## 4.2 Handling Un-convergence and Ensuring Tool Stability

*Convergence* of the iterations and the *stability* of the tool are closely linked to one another: an equation that does not converge, automatically leads to instability of the tool and failure of the calculation, as will be explained in short.

Certain parameter combinations (extreme ones), tested within the optimization process, may generate a delay or a crash in one of the loops. When an error appears in one cell, MS Excel displays a message, indicating the error type (e.g. “#Name”). Since all the equations in OPerA are interrelated, if that cell is required in a different loop, it will in turn, generate new errors (equations need to be fed with numbers, and will not understand error messages). Another reason for malfunction is the *MS Solver*, which is used within the macro that automatically matches the cruise line in the matching chart. Sometimes the *Solver* is unable to find the right solution, or it finds a solution that reaches the boundaries of the  $V / V_{md}$  ratio. This again, leads to a calculation crash.

To ensure convergence (and hence stability), before each calculation, certain key cells, having a major influence on the rest of the parameter chain, are re-initialized with *start values*. Without a re-initialization, the chain of errors is unsolvable and leads to a calculation crash. This re-initialization is performed via 2 programmed macros, called *stability macros* in the tool. The first macro re-initializes the key cells with constant start values. The second macro inserts the corresponding formulas back into the key cells. This gives *MS Excel* a safe starting point before every calculation.

The start values depend on the type of aircraft that is designed. Currently, default start values in OPerA are suitable for medium-sized aircraft. Table 4.1 gives the start values of the key cells that ensure the convergence of the iterations and the stability of the tool.

**Table 4.1** Start values of key-parameters for the iteration loops

Parameter	Symbol	Start value
Maximum take-off mass	$m_{MTO}$	73500 kg
Take-off thrust	$T_{TO}$	222400 N
Maximum zero-fuel mass	$m_{MZF}$	60500 kg
Zero-lift drag coefficient	$C_{D,0}$	0.0189

The macros can be called manually, when the user performs manual optimization. For an automatic optimization the user of OPerA has two alternatives available, which will later be explained in more detail: optimization with built-in algorithms, or optimization via connection with the software platform *Optimus*®. Both these alternatives are able to account for the stability macros: the built-in algorithms call these macros automatically, before each calculation. If an error appears, the respective experiment is neglected, while the next calculation is not affected. *Optimus*® is also able to work with macros. *Optimus*® interprets MS Excel errors as zeros. If the objective is to minimize a function, a zero value of this

function makes Optimus® believe that it is looking for the optimum in the right direction. Especially when applying Evolutionary Algorithms, this leads to wrong solutions. Additional constraints were set in Optimus® to ignore those experiments for which errors appear.

### 4.3 Design Space

The methodology implemented in OPerA requires about 230 input parameters, many of which are statistical factors (like the ones in Table 2.17) or experience values. This represents about 23 % of all parameters calculated in OPerA (i.e. about 1000). Among these, about 150 are used for calculating the geometry of the aircraft, especially the geometry of the cabin and cargo compartments. 20 of them are optimization variables.

The almost 1000 parameters describing the aircraft are grouped depending on their utilization. The pie chart in Figure 4.1 gives the reader a hint about the extension of OPerA.

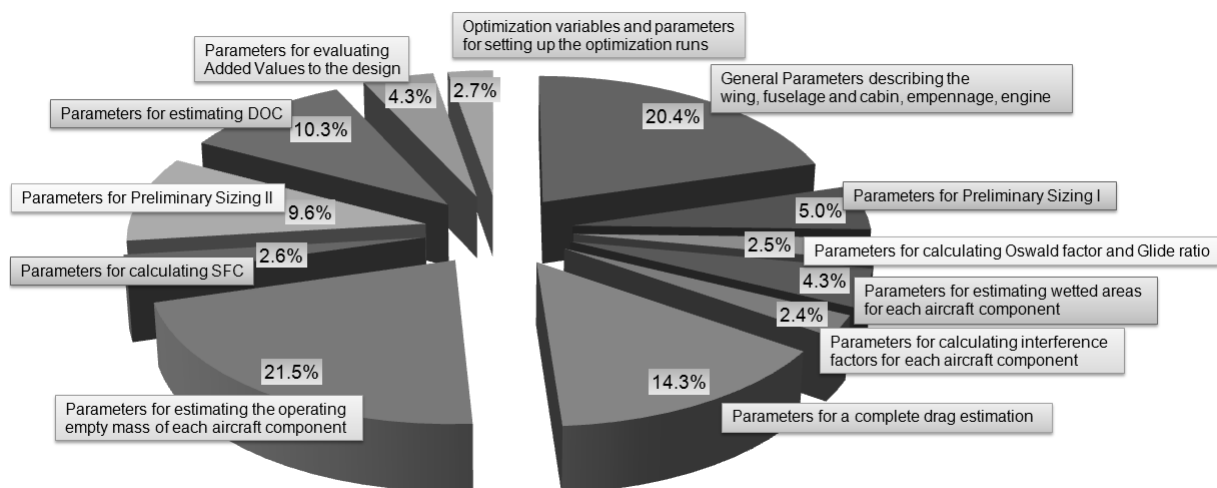

**Fig. 4.1** Parameter and parameter groups in OPerA

Optimal designs are searched in the design space given by the number of optimization variables – 20 in OPerA, and their boundaries (see Table 4.2). The size of this design space is quite high, compared to the attempts of Aircraft Design Optimization performed at Conceptual Design level in literature. Raymer, for instance, uses 7 variables for his optimizations in his doctoral thesis (**Raymer 2002**). The number of 20 variables is enough to ensure the optimization of all key aspects of the Aircraft Design at initial stage. It is also enough to ensure the right compromise between computation time and robustness. The maximum amount of variables considered in literature to be the limit of an accurate optimization, with today’s available algorithms, is 40 (**Verstraete 2008**). As such, the level of detail in OPerA is sufficient to analyze a great number of feasible concepts, and freeze a limited number of them for detailed, later, more expensive research.

**Table 4.2** Optimization variables in OPerA

Parameter	
Landing field length [m]	$S_{LFL}$
Take-off field length [m]	$S_{TOFL}$
Max. lift coefficient, landing for unswept wing	$C_{L,max,L,unswept}$
Max. lift coefficient, take-off for unswept wing	$C_{L,max,TO,unswept}$
Mass ratio, max landing to max take-off	$m_{ML} / m_{MTO}$
Aspect ratio	$A$
Number of engines	$n_E$
Number of passengers	$n_{PAX}$
Number of seats abreast	$n_{SA}$
Wing sweep at 25 % chord [°]	$\varphi_{25}$
Taper ratio	$\lambda$
Position of the vertical tail in case of cruciform configuration	$z_H/b_V$
Minimum distance from engine to wing over nacelle diameter	$z_{P,min}/D_N$
By-Pass ratio	$BPR$
Mach number, cruise	$M_{CR}$
Seat pitch [m]	$SP$
Aisle width [m]	$w_{aisle}$
Seat width [m]	$w_{seat}$
Armrest width [m]	$w_{armrest}$
Sidewall Clearance (at armrest) [m]	$S_{clearance}$

## 4.4 Calibration Test and Correction Factors

Based on the reference aircraft, for which detailed information was available, a number of parameters can be adjusted by multiplying them with a correction factor. For this study, the Airbus A320-200 was used as a reference aircraft. The A320 aircraft is a twin engine short to medium range aircraft built by the European company Airbus.

This reference aircraft was redesigned with OPerA. Having more detailed information available, correction factors were applied to certain parameters, so that the redesign resembled as much as possible with the original aircraft. The values of the main parameters, as resulted from the redesign, are given in Table 4.3. This redesign case of A320 performed to obtain the correction factors represented the calibration test of the tool. These correction factors are relative and hence applicable to any transport aircraft, from short to long range. Through them, tool generality is ensured. Table 4.4 lists the correction factors used during the calculations and optimization runs.

**Table 4.3** Parameters of the A320 aircraft, as resulted from the redesign with OPerA

Parameter	Symbol	Redesign Value	Original Value
Landing field length [m]	$S_{LFL}$	1447.8	1447.8
Take-off field length [m]	$S_{TOFL}$	1767.8	1767.8
Max. lift coefficient, landing for unswept wing	$C_{L,max,L,unswept}$	3.39	-
Max. lift coefficient, take-off for unswept wing	$C_{L,max,TO,unswept}$	2.95	-
Mass ratio, max landing to max take-off	$m_{ML} / m_{MTO}$	0.88	0.88
Aspect ratio	$A$	9.5	9.5
Number of engines	$n_E$	2	2
By-Pass ratio	$BPR$	6	6
Cruise Mach number (from payload-range diagram)	$M_{CR}$	0.76	0.76
Wing sweep at 25 % chord [°]	$\varphi_{25}$	25	25
Geometrical span [m]	$b_{geo}$	34.1	34.1
Taper ratio	$\lambda$	0.213	0.213
Number of passengers	$n_{PAX}$	180	180
Number of seats abreast	$n_{SA}$	6	6
Fuselage slenderness	$\lambda_F$	8.98	9.29
Maximum take-off mass	$m_{MTO}$	73500	73500
Fuel mass	$m_F$	13000	13000
Operating empty mass	$m_{OE}$	41244	41244
Specific fuel consumption [kg/N/s]	$SFC$	$1.65 \cdot 10^{-5}$	-
Cruise altitude [m]	$h_{CR}$	11861.2	-
Thickness ratio	$t/c$	0.12	-
Lift-to-drag ratio	$E$	17.5	-

**Table 4.4** Correction factors in OPerA as set for the calculations in this work based on the A320 as reference aircraft

Corrected parameter	Correction factor
$S_{wet}$	$S_{wet} / S_{W,ref} = 1.0864$
$C_{D,0}$	$C_{D,0} / C_{D,0,ref} = 1.163$
$m_{OE}$	$m_{OE} / m_{OE,ref} = 1.153$

The estimated *wetted area* was corrected via a factor of approximately 8 % to account for additional surfaces that are not included into the component-based approach (see Section 2.2). Another reason is that the equations used to calculate the surface area of the components represent an approximation of the real surface area, thus a certain degree of inaccuracy is involved.

The  $C_{D,0}$ , obtained with the component-based method, is in turn corrected with the correction factor  $C_{D,0} / C_{D,0,ref}$ . This factor accounts for unpredictable additional drag components, such as landing gear drag, or for cabin pressure leakage, doors and antennas. It also accounts for inaccuracies in the estimation method.

The operating empty mass,  $m_{OE}$ , is calculated for each component: wing, fuselage, horizontal and vertical tail, engine, nacelle, nose and main landing gear, systems and, additionally, the

operator's items. This estimation gets to be corrected with the factor  $m_{OE} / m_{OE,ref}$ , to account for the inaccuracy of the methods and for items that are not included into the decomposition.

## 4.5 Constraints

Besides the constraints imposed by requirements via the matching chart, as explained in Section 2, three additional constraints are built in OPerA. These constraints reject those experiments that do not comply. The selected optimization algorithm (as will be shown in the next section) will remember which parameter combination leads towards failed experiments and will not evolve towards that direction anymore. Thus, failed experiments appear especially in the beginning of the iterative process. The three mentioned constraints account for:

- 1.) Capacity to take the required fuel reserves on board (depending on mass ratio landing-to-take off)
- 2.) Capacity to respect airport wing span limitations (depending on airport category)
- 3.) Capacity to accommodate all required fuel (depending on wing geometry)

Concerning 1.), the landing mass ratio needs to respect the following relation:

$$m_{ML} > m_{MZF} + m_{F,res} \quad (4.3)$$

Concerning 2.), a *geometrical wing span* limitation is chosen by the user, depending on which airport category he wants to design the aircraft for (see Table 2.6). However, the optimizer allows a further increase in *effective wing span*, by automatically allowing *winglets*. The size of winglets,  $h_{WL}$ , is limited. The limit value can be set as required. In this study it was set to 2.4 m. Here, careful attention was given in deciding which parameters need to be calculated with effective values, and which with geometrical values. For example, drag and lift-to-drag ratio are calculated with effective values of the resulting aspect ratio.

Concerning 3.), the capacity to accommodate the *necessary fuel* for the flight mission is calculated from mission fuel fractions together with taxi fuel fraction (usually a design point in the payload-range diagram corresponding to the maximum payload should be chosen). Then, the *available fuel volume* is calculated from wing geometry with an equation from **Torenbeek 1986**. A check whether the fuel fits in the wing is performed. It is quite unlikely to have this constraint violated. If the optimal design states that the wing is not enough to accommodate fuel, additional center tanks (ACT) or tail tanks (ATT) may be embedded. Thus, this constraint does not reject experiments (designs that do not conform), but gives the hint to the user that some design change for creating additional fuel volume may be required.

## 4.6 Tool Particularities and Limitations

This section underlines and, where it is the case, calls into question some of the tool particularities in order to have the certainty that the right methodological approach was used.

### The Matching Chart

The *inner optimization* (represented by the Matching Chart) embedded into the formal optimization (represented by the Optimization Module) in OPerA, is a tool particularity that contributes to solution transparency and delivers the design point. As explained in Section 2, the design point is found automatically for each parameter combination that the Optimization Module generates with the algorithm for finding the optimum aircraft design. Yet, the question arises: does this approach always leads to the right design point, and finally to the optimum aircraft design?

Tested was also a different inner optimization approach: i.e. an “un-automatically” matching of the requirements for finding the design point. Instead of forcing the cruise line to go through the design point, it was let free, to see if it still goes through the design point. As a consequence, the ratio  $V / V_{md}$  became an optimization variable for the formal optimization process.

It was found that, in most of the optimization cases, the solution is very close to the one where  $V / V_{md}$  is automatically adjusted and that the design point lies fairly at the intersection of all lines. This means that, even a completely free parameter environment, with no constraint (such as the supposition that the cruise line must be part of the design point) tends to a solution that unifies all the requirements, including cruise, in a single intersection point: the design point. Performing this test ensured the author that the *automatic* inner optimization procedure is a good and plausible approach. Figure 4.2 stands as proof.

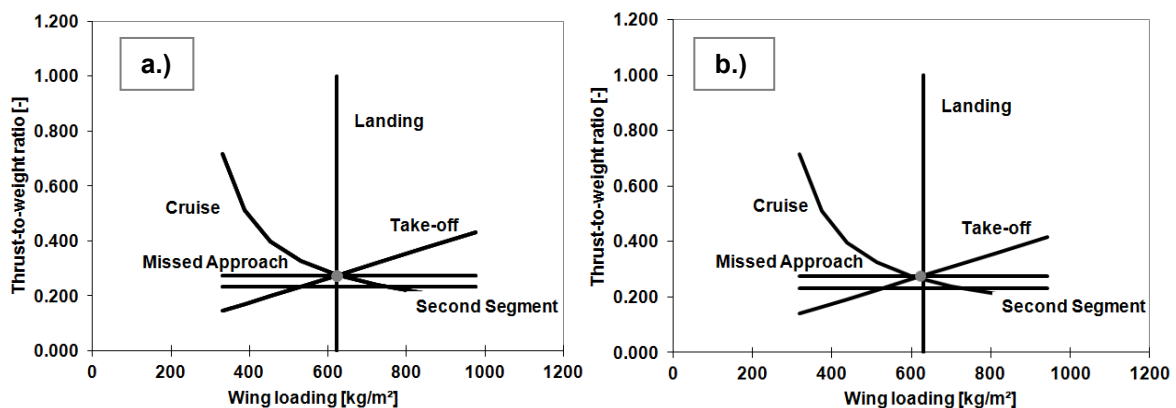

**Fig. 4.2** Matching chart for a 10 parameters optimization scenario. In case a.)  $V / V_{md}$  is automatically found by forcing the cruise line to match the design point (grey). In case b.)  $V / V_{md}$  is an optimization variable. Here, the cruise line freely results to be very close to the design point.



### Implementation of the Span Limitation

In Section 2.2 a discussion is made on winglets. It is specified that in OPerA winglets are automatically added in the case the airport span limitation is exceeded. In this way a higher aspect ratio is possible. As such, if the optimizer increases the aspect ratio that much that the span becomes greater than the airport limitations (listed in Table 2.6), then winglets are added, up to the (user modifiable) size of 2.4 m.

The optimizer varies the effective aspect ratio, and not the geometrical one. The relationship between them is:

$$\frac{A_{geo}}{A_{eff}} = \frac{1}{\left(1 + \frac{2}{k_{WL}} \cdot \frac{h}{b}\right)^2} . \quad (4.4)$$

The maximum aspect ratio achievable, depending on the span limitation, is then  $(A_{geo} / A_{eff})_{lim}$ :

$$\left(\frac{A_{geo}}{A_{eff}}\right)_{lim} = \frac{1}{\left(1 + \frac{2}{k_{WL}} \cdot \frac{h_{WL,lim}}{b_{geo,lim}}\right)^2} , \quad (4.5)$$

where  $h_{WL,lim} = 2.4$  m and  $b_{geo,lim}$  is the airport span limitation (for A320 aircraft,  $b_{geo,lim} = 36$  m).  $k_{WL}$  is the factor from Section 2.2.2.

The effective span depends on the effective aspect ratio (which is a variable for the Optimization Module) and on wing area (which is a result of the optimization process). In the calculation, the geometrical span used for further calculations (such as empennage parameters or landing gear mass) is:

$$b_{geo} = \begin{cases} b_{eff} , & \text{if } b_{geo} \leq b_{geo,lim} \\ b_{geo,lim} , & \text{if otherwise} \end{cases} . \quad (4.6)$$

Following (4.6), the geometrical aspect ratio is:  $A_{geo} = b_{geo} / S_w$ .

To see whether or not winglets are required, the following check is made:

$$\begin{aligned} & \text{if } b_{eff} \leq b_{geo,lim} , \text{ then no winglets are required} \\ & \text{else, winglets are required} \end{aligned} \quad (4.7)$$

The required size of the winglets is calculated with:

$$\frac{h_{WL}}{b} = \frac{k_{WL}}{2} \left( \sqrt{\frac{1}{A_{geo}/A_{eff}}} - 1 \right) \Leftrightarrow \frac{h_{WL}}{b} = \frac{k_{WL}}{2} \left( \frac{b_{eff}}{b} - 1 \right), \quad (4.8)$$

with  $A_{geo}/A_{eff} = \begin{cases} 1, & \text{if no winglets are required} \\ A_{geo,lim}/A_{eff}, & \text{if winglets are required} \end{cases}$

### Limitations of OPerA

OPerA was developed for CS 25 / FAR Part 25 *jet* aircraft<sup>1</sup>. It can incorporate short, medium and long range aircraft. It is limited to conventional configurations, but is able to analyze innovative configurations, derived from conventional ones<sup>2</sup>. It can also support cruciform tail configurations or aft mounted engines.

Mass and drag predictions are based on carefully selected or improved empirical or semi-empirical equations. No attempt was made to incorporate methods that work with real loads, calculate the stress in the material and do a preliminary structural sizing of the components.

OPerA does not calculate CG and only provides an approximative value for lever arm to size the tail surface. As such, no attempt has been made to provide data for 3-view-drawing. For example, the tool can predict if there is enough space under the cabin floor for cargo containers, can say which type fits, but it does not deliver a visualization of the cross-section. A 2D representation can be done however with *PreSto*, which is the next tool in line in the tool chain OPerA is part of (See Section 1).

These limitations are subordinated to the purpose of the tool. A higher degree of detail would alter the required degree of simplicity, necessary at this preliminary design stage.

## 4.7 Case Study: Redesign of Future A320 NEO Aircraft

NEO stands for New Engine Option and is the improved version of the A320 aircraft that is going to enter service in 2016. With two new engine options, namely Leap-1A (from CFM - the joint company of Snecma and General Electric), and PW GTF from Pratt & Whitney; with winglets called “sharklets” and other improvements, Airbus claims to have reached 15 % fuel savings, and 6.9 % cash operating costs (COC) savings (Press 2011). Table 4.5 summarizes all changes found in literature (mainly press releases) (Press 2011). These changes were implemented in OPerA, in order to see if improvements in the same range are to be obtained. Table 4.6 shows how these improvements were implemented in OPerA.

<sup>1</sup> A version is under development at Hamburg University of Applied Sciences for turboprop aircraft, PrOPerA

<sup>2</sup> One example is the braced wing aircraft, which is a promising concept, almost forgotten by the aircraft design community (as the results in Section 9 will show)

**Table 4.5** Improvements of NEO compared to original A320 aircraft

Improvements	Values of NEO	Values of A320
By-Pass ratio, BPR	10	6
Overall Pressure Ratio, OAPR	40	-
New shaped engine pylon	-	-
Increased fan diameter	1.980 m	1.734 m
Redesigned upper-belly fairing	-	-
Winglets called "Sharklets"	2.4 m	-
New galley concept	-	-
5 % of the airframe is lighter	-	-
Overall:	leading to:	
15 % fuel savings	extra 2 t of payload	
6.9 % COC savings	or extra 510 km of range	

The overall effect of the changes applied to NEO, according to the press releases, is a fuel economy of about 15 % that may be exploited by increasing range with 510 km or by increasing payload with 2000 kg. If 3.5 % fuel savings are kept, than an increase in range of about 185 km (100 NM) or extra 500 kg of payload would be possible (**Press 2011**).

In order to see if the same fuel savings are obtained with OPerA, all the improvements were implemented, as indicated in Table 4.6.

The improved engine pylon shape was accounted for by reducing the wetted area of the pylon by 20 %. The nacelle interference drag factor was correspondingly reduced: it was set to 1.3, instead of 1.42. A 5 % reduction of the fuselage wetted area was assumed plausible after the new design of the upper-belly fairing. The 2.4 m winglets allowed a new effective aspect ratio of 11.65 (compared to 9.5), and overall an increase in lift-to-drag ratio up to 19.4. The increase in fan diameter of the new engine was incorporated without the need to modify the lengths of the nose and main landing gear. As such these lengths were kept constant in OPerA, too.

**Table 4.6** Implementation of NEO improvements in OPerA

Improvements	Values implemented in OPerA	Effect
BPR	10	Improved specific fuel consumption: $SFC = 1.4 \cdot 10^{-5}$ kg/N/s
OAPR	40	
New shaped engine pylon	20 % wetted area reduction	Improved interference drag: $Q_N = 1.3$ Improved lift-to-drag ratio: $E = 19.4$
Redesigned upper-belly fairing	5 % fuselage wetted area reduction	
Sharklets	2.4 m	New effective aspect ratio: $A = 11.65$
Increased fan diameter	1.98 m	Constant landing gear lengths
New galley concept	Correction factor for $m_{OE}$	Constant $m_{OE}$
5 % of the airframe is lighter		

While replacing the values in Table 4.6, other parameters were kept constant, such as wing area. The lighter airframe was accounted for via a correction factor on the operating empty mass, but the maximum take-off mass of the aircraft was assumed to be the same as the original aircraft.

When keeping the same range and payload as for the A320 aircraft, the cumulative fuel saving, after manually implementing the changes in OPerA, is 14.4 %. The DOC savings are less: about 2.5 %. The 14.4 % reduction in fuel translates into 1867 kg of payload. Or, in other words, the fuel mass dropped from 13000 kg to 11133 kg, making room for additional payload.

These measures taken with NEO make out of the original A320 a more productive one. The main areas where the manufacturers made changes were the propulsion – through increased BPR engine, and the aerodynamic – through winglets as a solution to an already built wing. The quite substantial 15 % fuel reduction was hence obtained without much design freedom. This reduction was obtained also with OPerA, after manually redesigning the NEO aircraft. Even much higher improvements may be obtained from the same conventional configuration if more design freedom is allowed. OPerA is able to make such assessments and to document them, not only for conventional configurations but also for innovative ones, as it will be shown in the results section of the work.



# 5 Brief Theoretical Background on Optimization and Algorithms Selection

## 5.1 Introduction

Due to the achieved maturity in mathematical and computational tools, optimization algorithms have known a large development (Verstraete 2008). Yet, implementing formal optimization as early as in preliminary design stage (Preliminary Sizing and Conceptual Design) is a difficult task. Isikveeren 2002 explains:

*[...] the conceptual design process is not strictly a logical and sequential series of events, thus coming into conflict against the rigid structure dictated by computer programming.*

Where computer programming has been used, the difficulty laid in

*the feeling the software is “designing” the aircraft as opposed to the designer because the perception is the tool requires minimum input from the human in the loop and the final vehicular design is deemed immediately invalid. This phenomenon is sometimes ignominiously referred to as the “black-box” solution (Isikveeren 2002).*

These are reasons why an automated, computer aided design at the initial stage is not yet an established procedure and still needs to be explored. However, the quotes above are a critique of software tools. As long as the “black-box” solutions are avoided, optimization algorithms could still be addressed as “black-boxes”, created by the specialized scientific community. For example, the same author (Isikveeren 2002) applied Genetic Algorithms in his tool QCARD by using the Matlab® Optimization Toolbox, which is a collection of predefined algorithms. In the end, the most important thing is the *transparency of the solution*. The designer can use the simpler “black-box” algorithm as long as it is incorporated into a tool delivering a *traceable* solution.

Nevertheless, finding this solution requires setting specific *criteria* for eventually *selecting* the right optimization strategy – the right “black box”.

In this work two optimization approaches have been employed: First, algorithms as a “black-box” have been used by connecting the created tool, OPerA, to a commercial optimization platform, Optimus®. Optimus® delivers a large database of algorithms for different classes of problems. Second, an algorithm was selected and programmed in OPerA, first of all to achieve independency from a commercial tool like Optimus®. In this second case, the algorithm was carefully selected from the large database of algorithms in Optimus®, and programmed in Visual Basic for Applications; for the user of OPerA, it is still perceived as a black box, called by pressing a button.

In both cases, the most important criteria for selecting the right optimization approach, in the view of the topics addressed by this work, were:

- 1.) The ability of the algorithm to converge, despite abnormalities (robustness).
- 2.) The ability of the algorithm to handle very large and disjoint design spaces.
- 3.) The ability of the algorithm to deliver the solution in an acceptable amount of time.
- 4.) The simplicity of the algorithm (in concept, and hence programming).

The first two criteria were considered of primary importance during the selection process.

The following subsections give a brief overview of the theory of optimization algorithms with the purpose of, eventually, selecting the right *class* of optimization algorithms – the right shelf of “boxes” – that satisfies the criteria and promises to aid delivering the answers to research Questions 1 and 2. All important representatives of the respective class are to be tested in OPerA with Optimus®, and finally the algorithm best meeting the criteria is to be selected.

## 5.2 Gradient and Non Gradient Based Categories of Optimization Algorithms

The most common classification of optimization algorithms divides them into two categories, depending whether the objective function is derivable or not: gradient-based and non-gradient-based algorithms.

*Gradient based algorithms* search the direction towards extremum, with the help of the partial *derivatives* of the objective function. *Non-gradient-based algorithms*, or zero order methods, use the values of the *function* in the search for the optimum. First and second order methods use first, respectively second order derivatives of the objective function in their search.

Table 5.1 summarizes the main properties of each of the two categories. These properties were selected after investigating the opinions of several authors: **Verstraete 2008**, **Giannakoglou 2008a**, **Rai 2008**, **Gonzales 2008**, **Vanderplaats 1984**, **Box 1965**, **Schwefel 1981**.

The disadvantage of non-gradient methods is that they require a higher number of function evaluations (**Giannakoglou 2008a**, **Rai 2008**, **Gonzales 2008**). However, they can address design spaces with disjoint feasible regions and can use parallel computing resources, hence increasing execution speed (**Rai 2008**).

**Table 5.1** Summary of properties for gradient and non-gradient based algorithms

Gradient-Based Methods	Non-Gradient-Based Methods
Require gradient information about the objective function; The gradient is calculated at considerable computational cost; Objective function must be continuous, derivable and uni-modal; Show weak performance for noisy functions; Risk to get trapped in local minimum; Multi-objective optimization is only possible through translation to single-objective optimization, through a weighted sum of the objectives.	Require a large number of function evaluations, including for a reduced number of variables; Allow direct implementation of constraints, Are more effective, and work in noisy environments; Suitable for global optima (yet not guaranteed); Allow multiple objectives.

The conditional property of an objective function, for a gradient-based method to work, is, as already stated, its derivability and continuity. The objective functions in OPerA (detailed discussion in Section 8) are the result of many complex parameter correlations, following the implementation of the Preliminary Sizing and Conceptual Design methodology (presented in Sections 2 and 3). Some parameters are discrete, such as number of engines, or number of seats abreast. Unless these parameters are user defined and excluded from the objective function, gradient based methods would not work. As such, a gradient based approach would not be able to cover the most general case, where all parameters are set free, including the discrete parameters. *Consequently, it has been decided to select an algorithm from the category of zero-order methods* in order to ensure general validity, independent from which parameters the user turns on and off during the optimization process. From this category of algorithms – non-gradient based, or zero order, a class of methods will be eventually selected.

### 5.3 Non-Gradient Based Category of Optimization Algorithms

There are several techniques employed by non-gradient (zero-order) methods. The most widely spread, are briefly presented in this section. Depending on these techniques, several *classes of methods* were differentiated by the scientific community. Mentioned in the introduction was the class of Evolutionary Methods. There are other methods as well. See Figure 5.1 for a visual summary. The scheme can be, of course, further completed.

Figure 5.1 also visualizes the streamline of the selection process: the category of gradient-based algorithms has been already ruled out. The next step is selecting the right class, and finally the right algorithm.



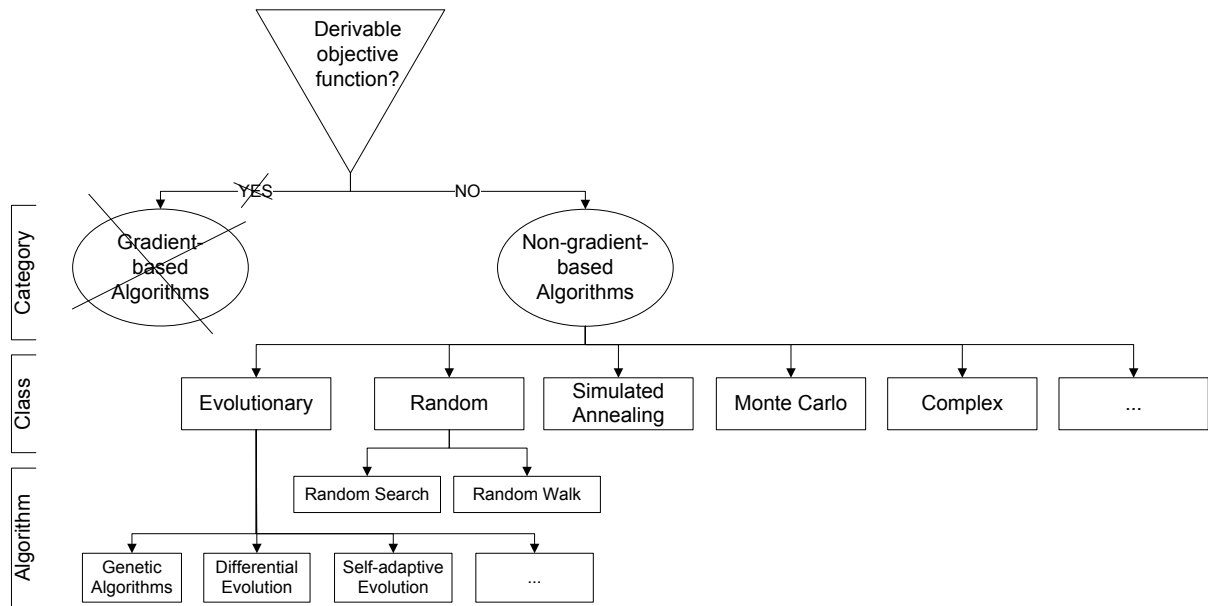

**Fig. 5.1** Decomposition of the two main categories of optimization approaches into classes and eventually optimization algorithms

*Random Search* is the simplest zero order approach for minimizing an objective function (**Verstraete 2008**). A large number of candidate vectors (assuming, of course, a multi-variable function) are randomly selected; the one satisfying all constraints, in the best way, is the optimum. This method is not accurate enough, especially for higher number of parameters, and requires many function evaluations. An improved version is *Random Walk*. The improvement consists in the fact that the new design, is based on a perturbation applied to the previous design  $\vec{X}_{i+1} = \vec{X}_i + \alpha_i \cdot \vec{S}_i$ , where  $\vec{S}_i$  represents a normalized randomly generated vector and  $\alpha_i$  is a constant. The new design,  $\vec{X}_{i+1}$ , replaces the current design,  $\vec{X}_i$ , if it is better (**Verstraete 2008**, **Vanderplaats 1984**).

*Simulated Annealing* is based on the analogy of the simulation of the annealing of solids **Laarhoven 1987**. A random perturbation is performed on an existing design, similar to Random Walk; if the new design is worse, it is not necessarily rejected. The replacement decision is based on a virtual temperature and energy. The energy reflects the difference in performance between the two designs. Temperature decreases with iteration step and reduces the probability of accepting a worse design as a temporary design. This is beneficial for the global optimization as it moves away from the current design, to find a better one (**Verstraete 2008**). In Material Science, recombination of molecules to form the solid, after they were heated to a maximum temperature, is based on the difference in energy level of the two molecules and the temperature of the bath. The convergence is increased, compared to Random Walk, but still a high number of function evaluations is required (**Verstraete 2008**). There are several simulated annealing techniques. Where they differ is in the number of variables that are perturbed, the criteria to reduce temperature, and the way to compute the probability to accept a worse design (**Verstraete 2008**).

In analogy to the *Simplex* procedure conceived by Nelder and Mead (**Nelder 1965**) for unconstrained problems (not to be confused with the Simplex Algorithm of linear programming), the *Complex* algorithm was developed by **Box 1965** in particular for constrained problems. Complex stands for constrained simplex. Complex algorithm uses more points during the search process (**Amadori 2008**). Both algorithms use geometric shapes to decide the search direction. For an  $n$  variables optimization problem, the Complex algorithm uses a set of  $m$  points such that  $m \geq n + 1$ . The objective function is evaluated for each point; the worst point is replaced by reflecting it through the geometrical center of the  $m - 1$  remaining points.

The class of *Evolutionary Algorithms* is the most widely used population-based, gradient-free, stochastic optimization approach (**Giannakoglou 2008a**). Algorithms in evolutionary class are numerous. As such, some of them are presented in a (next) separate section.

## 5.4 The Class of Evolutionary Algorithms

The idea of using Darwinist evolution as an optimization technique started in the late 50', early 60' (**Gonzales 2008**). A population of candidates evolves towards an optimum, using operators inspired by natural selection.

There are many types of Evolutionary Algorithms, some better than the other, since a continuous, dynamic process of improvement is undergoing in the scientific community specialized in this area. In the last decade researchers studying Evolutionary Methods have unified evolutionary approaches, such as Genetic Algorithms (GA), Evolution Strategies (ES), Evolutionary Programming (EP), Mimetic Algorithms (ME), Differential Evolution (DE) and others, under the single name of *Evolutionary Algorithms* (EA) (**Gonzales 2008**). **Deb 2002** presents numerous evolutionary algorithms. This section describes the most common ones.

All Evolutionary Algorithms share the following *elements*:

- *Individuals* – single solution of the simulated numerical problem; can be binary-coded (like GA) or real-coded (like DE) (**Gonzales 2008**),
- *Population* – sum of possible solutions,
- *Generation* (also called *Iteration*) – parallel examined possible solutions,

and the following *operators*:

- *Evaluation* – quality assessment of an investigated solution,
- *Selection* – individuals are selected, based on pre-defined criteria, for reproduction or survival to the next generation, in order to get to a desired evolutionary response,
- *Recombination* (also called *Cross-over*) – two or more “parents” (individuals) combine, using different strategies, to generate a third,

- *Mutation* – intervention to increase diversity and to expand search into areas not represented by current population.

*Genetic Algorithms (GA)* are the most popular among evolution strategies. Details about this type of algorithms are presented by many authors (**Gonzales 2008**, **Verstraete 2008** etc.). Here listed are those aspects that make GAs *different* from usual numerical optimization tools (and these aspects also contribute to their robustness) (**Gonzales 2008**):

- GAs are indifferent to problem specifics (example: the value of drag in airfoil shape optimization, which represents the fitness function)
- GAs are using codes of decision variables by adapting chromosomes (binary strings representing parameters), rather than parameters themselves. The possible solution is then a finite-length string.
- Populations are processed via evolutive generations, in contrast to point by point conventional methods, that risk to get trapped in local minimums.
- GAs use randomized operators instead of deterministic rules.

Most of the above mentioned differences are valid also for other evolutionary methods.

In the last 15 years a promising evolutionary method, called *Differential Evolution (DE)* has been developed (**Price 1997**). In contrast to GAs, it does not require the transformation of variables into binary strings (**Verstraete 2008**). An author who further developed this type of algorithm is M. Rai (**Rai 2008**). The main advantage of this algorithm is its simplicity correlated with a high efficiency. From a population of members – possible designs, three members  $\vec{A}_k$ ,  $\vec{B}_k$  and  $\vec{C}_k$  are randomly picked. A new trial member is calculated as  $\vec{Y}_k = \vec{A}_k + F \cdot (\vec{B}_k - \vec{C}_k)$ , where  $F$  is a user defined proportion,  $F \in (0,1)$ , that serves as a control parameter. This trial member is selected as a candidate to a better solution, that survives the next generation (or iteration), if a uniformly distributed random value, belonging to the interval (0,1) is smaller than a user defined constant, also between (0,1) that serves, as  $F$ , as control parameter. This test is called *recombination* – a common operation to all evolutionary methods, as stated above. This simple approach ensures a straightforward “evolution” of the better candidates towards the solution.

Another evolutionary scheme is *Self Adaptive Evolution (SAE)* (**Schwefel 1981**). This Evolution Strategy is explained in the theoretical background of the optimization software Optimus® (**Noesis 2008**). Here, during the recombination process, multiple parents are selected to generate one new individual. This is what is called multi-recombinant scheme. However, it has more user control parameters than *Differential Evolution (DE)*, and during the tests with OPerA, showed a poorer behavior.

## Evolutionary Algorithms Improvements

The attempts to reduce the high number of function evaluations, which is the main inconvenient of the evolutionary methods, have lead to several types of improvements that were associated to conventional EA methods. **Verstraete 2008** presents a brief summary:

- *Distributed EA*: the entire population is subdivided into islands that evolve in isolation; then promising individuals are exchanged between islands.
- *Hierarchical EA*: is a combination of conventional EA with a low-fidelity model; promising individuals resulted from the easier, low-fidelity model, are then re-evaluated by the high-fidelity model. Usually this is applied together with Distributed EA.
- *Metamodel assisted EA*: an even lower-fidelity model is applied, not anymore based on a physical model, as before, but on an interpolation of already analyzed individuals with a high-fidelity model.

## Number of Evaluations versus Robustness

As listed in Table 5.1, each category of algorithms is better either for its robustness, or for its computational savings. **Schwefel 1997** states:

*"[...] there cannot exist but one method that solves all problems effectively as well as efficiently. These goals are contradictory."*

Hence, there must be a trade-off between the optimum quality and the computational effort required. If robustness is important, EAs are a good choice (**Verstraete 2008**). Among acceleration techniques, the metamodel assisted techniques are more attractive (**Verstraete 2008**).

For this research, the more important criterion was robustness, even if, for a larger amount of variables, the computational expense increased.

## Number of Variables

A drastic impact on the design space and the number of required function evaluations has the number of variables. **Verstraete 2008** states that, nowadays 40 parameters are considered to be the maximum achievable. Above 40, optimization algorithms perform poorly. Daniel Raymer (**Raymer 2002**) (mentioned in the introductory section) performed his aircraft preliminary design optimization with 7 variables. This study includes 17 real variables and 3 integer variables, in total 20 Aircraft Design parameters.

## 5.5 Class and Algorithm Selection

The technique of nature imitation, used by the *class of Evolutionary Algorithms (EA)* was selected for application in this work for several reasons. First due to its extensive utilization in Aircraft Design problems (see Section 1.4.2). Second due to its large development and its high number of representatives, that ensured a large palette of algorithms from which to select. Third, due to its ability to fulfill all the important criteria mentioned before (especially the first two) in an (according to literature) at least satisfactory manner.

The *algorithm* selection for implementation in OPerA followed after performing tests with a specialized commercial tool, namely Optimus®, developed by Noesis Solutions, Belgium. This software platform, dedicated to optimization, includes all modern optimization algorithms, and offered the possibility to understand how each algorithm behaves to our design problem. Tests were made for both smaller and larger design spaces, given by 4 up to all 20 design variables.

Table 5.2 lists the main evolutionary algorithms that were tested with Optimus® and the conclusions of the tests, expressed through plus points.

**Table 5.2** Selection of the optimization algorithm

Criteria \ Algorithm	Differential Evolution	Self-Adaptive Evolution	Simulated Annealing	Random Search
Robustness	+++	++	++	++
Handling large and disjoint design spaces	+++	+++	++	++
Computation time	+++	++	+++	+++
Simplicity	+++	+	++	+++
Ranking	1	4	3	2

Following these results, selected was the *Differential Evolution Algorithm*, developed by Price and Storn (**Price 1997**).

For less complex optimizations, when only one variable is varied, a very simple and rapid procedure has been adopted and programmed in OPerA, additionally to Differential Evolution. It is called (in Optimus®) *DOE Diagonal* (DOE stands for Design of Experiments) and can be used for a fast exploration of the design space, by evaluating the objective function in equally distanced points of the domain of definition.

Both algorithms, as well as their implementation in OPerA, are described in greater detail in the (next) Section 6.

## 5.6 Optimization Software Optimus®

It was mentioned just before, that Optimus® was used for testing several promising algorithms in OPerA. It was found adequate to dedicate a subsection for briefly presenting the features of this commercial tool.

Optimus® by Noesis Solutions (Belgium) is a Process Integration and Design Optimization software. It works as a platform that identifies the best design candidates by managing a parametric simulation campaign while using the software tools of the user (in this case, MS Excel) (Noesis 2011).

Figure 5.2 shows the workflow window, where the simulation is set up. The objects with which a workflow is built are: input and output parameters, input and output files, constraints and action items (in our case, MS Excel). Through the action items Optimus® executes the simulation codes (in our case, MS Excel macros) without user intervention.

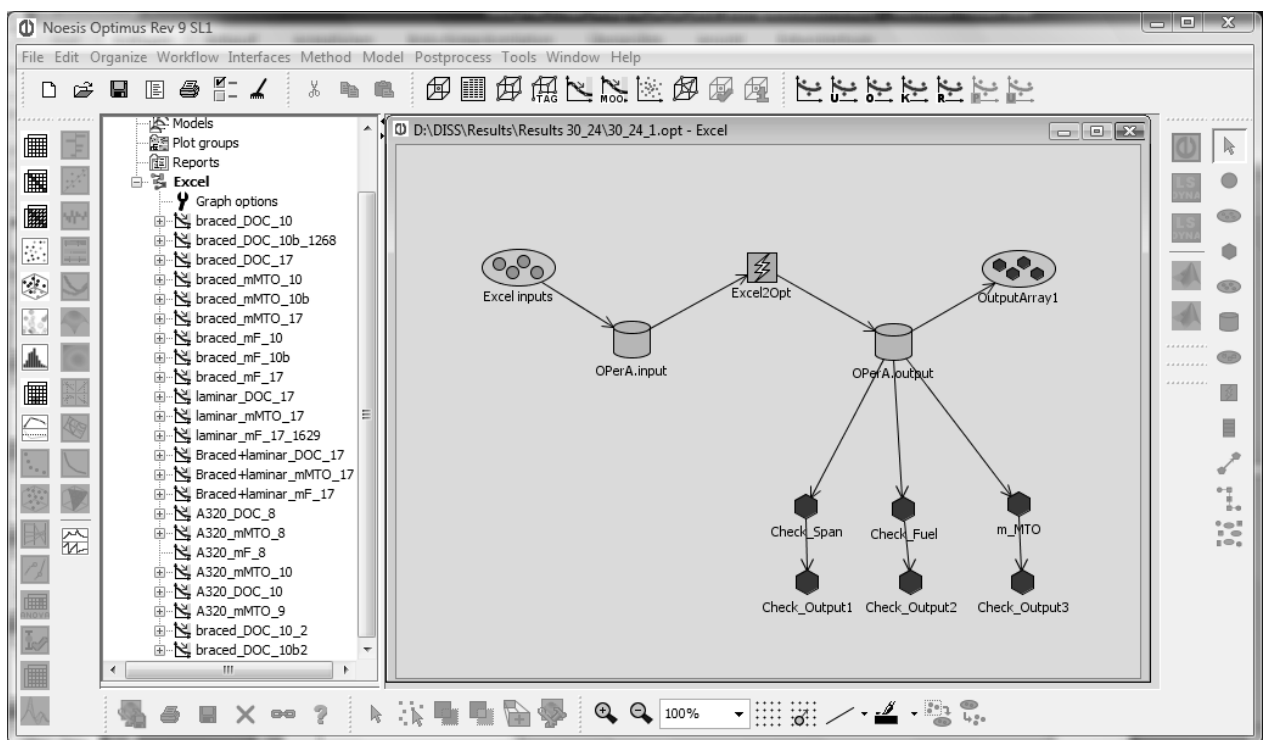

**Fig. 5.2** An example of an active workflow window in Optimus®

Optimus® helps visualizing and exploring the design space, by using a combination of gradient methods for a quick analysis – or Evolutionary Algorithms where multiple hills and valleys are anticipated in the response surface (Noesis 2011). The design optimization methods available in Optimus® allow the following (Noesis 2011):

- 1.) Design space exploration, such as Design of Experiments (DOE) and Response Surface Modeling (RSM);

- 2.) Numerical optimization, based on gradient-based local algorithms or evolutionary global algorithms, both for single or multiple objectives with continuous and/or discrete design variables;
- 3.) Robustness and reliability engineering, including methods to assess and optimize the variability of design outputs based on variable design inputs.

*For understanding the design space*, Design of Experiments (DOE) techniques are suitable. DOE is a mathematical methodology that defines an optimal set of experiments in the design space, in order to obtain the most relevant information possible with the highest accuracy, at the lowest cost. This scientific exploration of the design space is a fast way to acquire relevant information with minimum computational effort (**Noesis 2008**).

DOE methods included in Optimus® are classified into two categories: *orthogonal designs* and *random designs*. The orthogonality of a design means that the model parameters are statistically independent. It means that the factors in an experiment are uncorrelated and can be varied independently. A random design means that the model parameter values for the experiments are assigned on the basis of a random process. The most commonly used random DOE method is the so-called Latin Hypercube Design (LHD) (**Noesis 2008**).

For OPerA, two DOE methods were found interesting: *DOE Diagonal*, for single parameter variations (this was selected for inclusion in OPerA as a simpler alternative to Differential Evolution) and *Latin Hypercube*, for a design exploration with more variables (not necessary and too complicated for an independent inclusion in OPerA).

*For numerical optimization*, Optimus® contains three gradient based algorithms (Nonlinear Programming Quadratic Line search, Sequential Quadratic Programming and Generalized Reduced Gradient), another local optimization algorithm (Adaptive Region), four global algorithms (Differential Evolution, Self-Adaptive Evolution, Simulated Annealing and Efficient Global Optimization), one discrete algorithm (Mixed Integer Programming) and a Random Search algorithm.

*For multi-objective optimization*, Optimus® includes some methods for finding Pareto frontiers, among which Non-Dominated Sorting Differential Evolution, which is an evolutionary method derived from DE. Multi-objective optimization was not considered worthwhile at the level of detail that OPerA ensures; hence a more extended evaluation of the approaches was not performed.

# 6 Implementation of Selected Algorithms in OPerA

As stated before, in order to create an independent *Optimization Module* in OPerA, selected algorithms were computed in VBA (Table 6.1):

- *DOE Diagonal* for single objective, single parameter variation;
- *Differential Evolution* for single objective, single and multi-parameter variations.

**Table 6.1** Algorithms of the Optimization Module in OPerA

	Single Objective	Single Parameter	Multiple Parameters
DOE Diagonal	X	X	
Differential Evolution	X	X	X

## 6.1 Single Parameter Optimization with DOE Diagonal

For single input parameter variations, a very simple and very fast algorithm was implemented in OPerA. The algorithm is called (in Optimus®) *DOE Diagonal*, and, compared to *Differential Evolution*, it explores uniformly the design space, by calculating the objective function at equal intervals within the low and high boundaries, depending on a user-given *step-width factor* (or *fineness*) (see Figure 6.1). DOE stands for Design of Experiments.

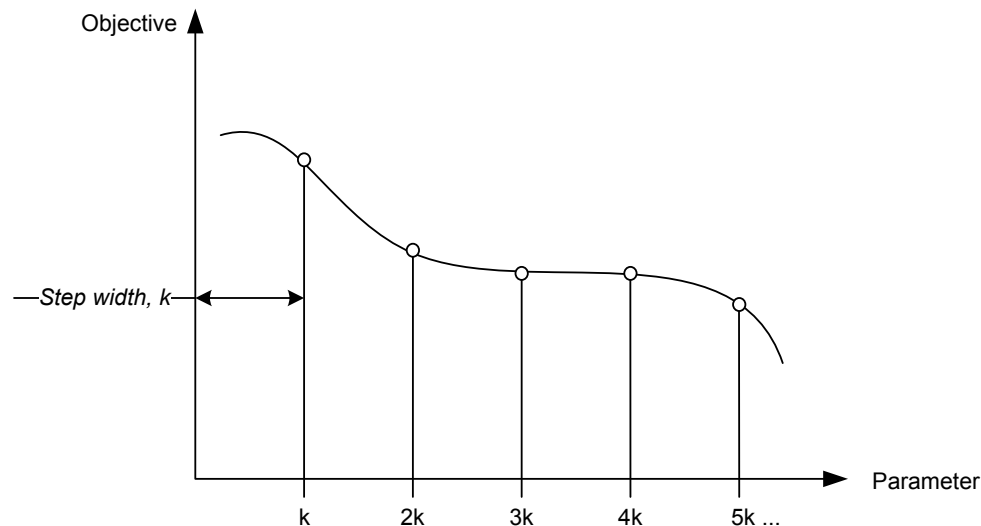

**Fig. 6.1** The DOE Diagonal algorithm explores the design space by evaluating the objective function in equally distributed points within the design space interval.



## 6.2 Single and Multiple Parameters Optimization with Differential Evolution

### 6.2.1 Description

Differential Evolution (DE) is an efficient population-based global optimization method that was originally developed by Price and Storn (**Price 1997**). It was later developed by Rai in (**Rai 2008**) to cover also multiple objective optimizations.

As the Genetic Algorithms (GA), it uses the same main concepts of *mutation*, *recombination* and *selection*. The mathematical description of the algorithm (**Rai 2008**, **Verstraete 2008**, **Noesis 2008**) for a single objective optimization is described below.

*Premise:*

$\vec{X}_k = (x_1, x_2 \dots x_n)$  is a population member, from generation (or iteration)  $k$ .

$\vec{A}_k \neq \vec{B}_k \neq \vec{C}_k$  are randomly picked members from the same generation, different from  $\vec{X}_k$ .

*Mutation:*

A trial vector  $\vec{Y}_k$  is obtained by calculating the *difference* between two randomly chosen population members,  $\vec{B}_k$  and  $\vec{C}_k$ , and adding a (user defined) proportion of it,  $F \in (0,1)$  to the third randomly chosen member,  $\vec{A}_k$ :

$$\begin{aligned} \vec{Y}_k &= \vec{A}_k + F \cdot (\vec{B}_k - \vec{C}_k) \\ y_i &= a_i + F \cdot (b_i - c_i), \quad i = \overline{1..n} \end{aligned} \quad (6.1)$$

*Recombination (or cross-over):*

The candidate vector  $\vec{Z}_k$  (to a better solution) is obtained as follows:

$$z_i = \begin{cases} y_i & \text{if } r_i \leq C \\ x_i & \text{if } r_i > C \end{cases} \quad (6.2)$$

where  $r_i \in [0,1)$  is a uniformly distributed random value and  $C \in (0,1)$  is a user defined constant.

*Selection:*

The candidate vector,  $\vec{Z}_k$  is compared to the original vector,  $\vec{X}_k$ . The fittest (in this case, the one that minimizes the objective function) survives to the next generation:

$$\vec{X}_{k+1} = \begin{cases} \vec{Z}_k & \text{if } f(\vec{Z}_k) \leq f(\vec{X}_k) \\ \vec{X}_k & \text{if } f(\vec{Z}_k) > f(\vec{X}_k) \end{cases} \quad (6.3)$$

There are some control parameters that the user needs to set:

- Population size* defines the number of designs (members) that are evaluated during each iteration (generation). To avoid an endless loop, the population size should be greater than 7. A good choice is more than 5 times the number of variables (genes) (**Noesis 2008**). A larger population increases the probability of global convergence at the cost of increased number of function evaluations and computation time.
- Weighting factor, F* Good values are between 0.5 and 1.0 (**Noesis 2008**). In contrast to higher values, lower values (e.g. 0.5) provide a higher convergence probability, but slow down the optimization process.
- Cross-over factor, C* This factor quantifies how many of the individuals are taken from previous generations without adjustment. Low values increase the risk of local optima, as good designs survive longer. **Noesis 2008** indicates that a good setting is between 0.7 and 0.85.
- Number of iterations* If this factor is too low, it may be that the optimum is not found. If it is too high, the number of function evaluations increases, and thus the computing time. A minimum of 10 iterations is recommended (**Noesis 2008**).

## 6.2.2 Implementation

Following the mathematical description, the algorithm was developed in VBA (Visual Basic for Applications) based on the steps in the diagram from Figure 6.2.

Within the code, additional stability macros are called before each evaluation (see Section 4). If an error occurs, it will not be considered as a candidate and will not influence the evolution process.

The interface in OPerA is simple: the user chooses which variable he wants to vary by selecting “Yes” from a “Yes/No” combo box, assigned to each variable. The same type of selection is performed for objective functions and for output variables. The user also needs to set the user-defined constants (default values are given in bold blue). Different warning messages appear in the case of faulty selections or assignments. In the same way the population size and the number of iterations need to be set.

Command buttons are created for each code (one for DOE Diagonal and one for DE). Once the user set-up is completed, the optimization starts “on the press of a button”.

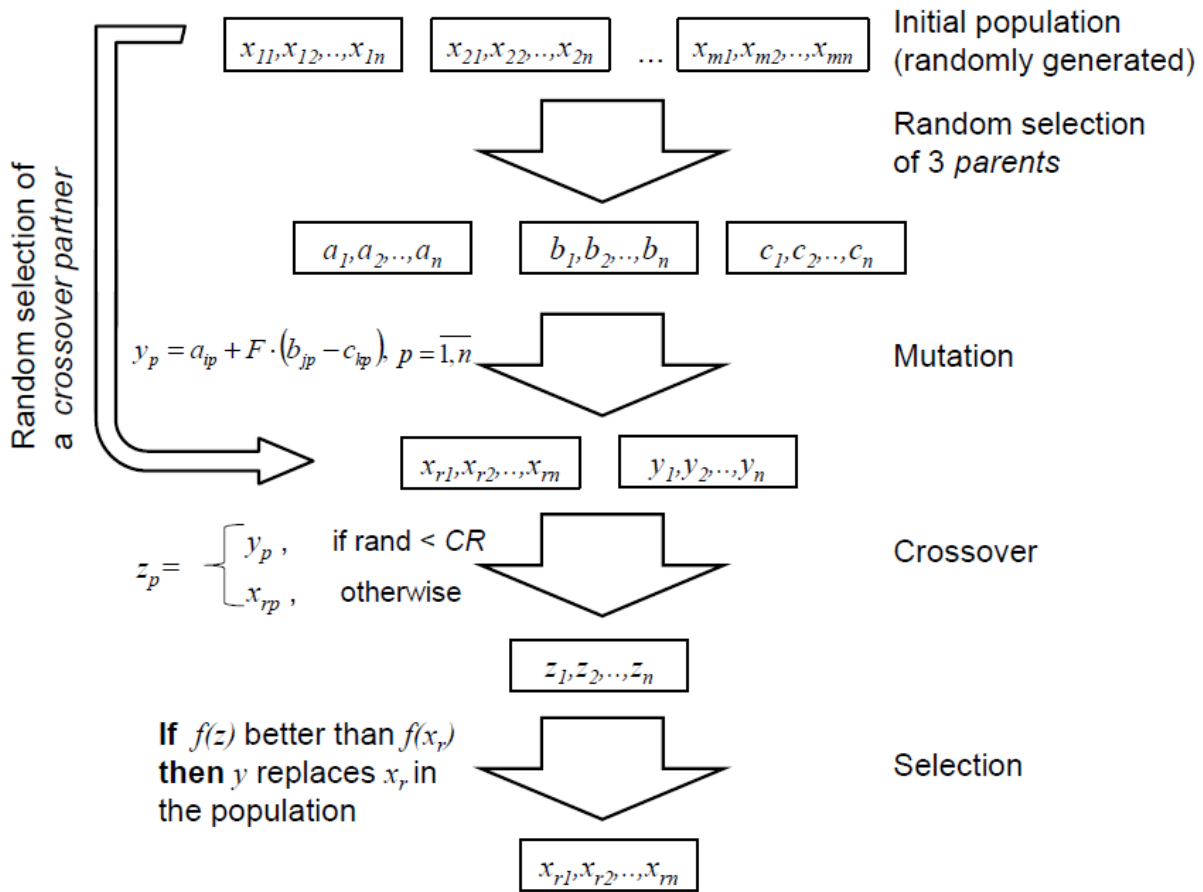

**Fig. 6.2** Standard Differential Evolution algorithm

The default values of the user-defined constants are those that delivered best convergence rate and number of better candidates during the tests performed on the medium range A320 aircraft (they are discussed below). Recommended values from literature are: 0.7 for weight factor,  $F$  and 0.85 for cross-over rate,  $C$ .

The results are displayed in a separate *Results* sheet (one for each algorithm) from where the user himself must plot the variations he wishes to visualize. Here only the initial population and the better candidates, obtained after each iteration, are displayed.

There is one minor difference between the algorithm implemented in OPerA and the one described in the Optimus® technical documentation. In the *Selection* process of the VBA algorithm the new fitter member ( $z$ ) replaces the old one ( $x$ ) in the population, while in Optimus® the fitter member is transmitted to a new generation. As a result, in the VBA algorithm the new fitter member can be involved in the creation of new members just one iteration after its appearance, while in Optimus® an entire new generation is created with combinations of members belonging only to the previous generation. The implication of this difference is a possible faster convergence of the VBA algorithm, but a slightly higher risk of convergence towards local optima.

Despite the fact that the VBA algorithm was very similar to the algorithm described in the Optimus® technical documentation, the optimizations done with the VBA algorithm showed a slightly poorer convergence compared to the Optimus® experiments<sup>1</sup>. In Figure 6.3 the minimum DOC obtained with Optimus® is 1.3598 US\$/NM/t of payload, while the VBA finds a value of 1.3623, after a double number of iterations, yet performed in the same amount of time. (The experiment used to test the VBA code and its convergence (Figures 6.3 to 6.5) is the experiment called (in the results section) A19a-DOC, in which all design parameters are free.)

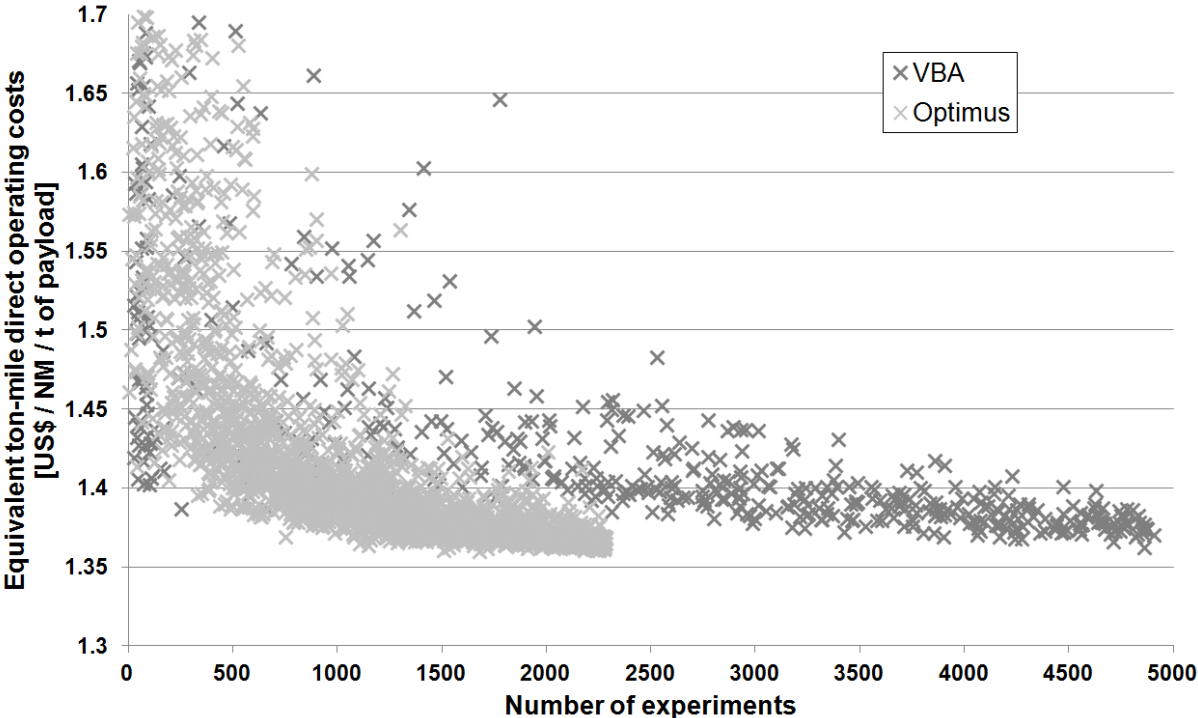

**Fig. 6.3** VBA and Optimus® results for Direct Operating Costs optimization

Results displayed in Figure 6.3 were produced in VBA with the standard value for the weight factor of 0.7. In Optimus® the default value for  $F$  is as well 0.7. Initial population generated in VBA is visible on the vertical axis. The rest of the points represent those new members that are better than their predecessors. The VBA algorithm didn't manage to reach the optimum calculated with Optimus® despite a higher number of iterations, although the two values are very close. (The time required by the two optimizations was similar). It is very likely that the actual algorithm implemented in Optimus® is much more complex than the one described in the technical documentation. That would explain its faster convergence and the higher amount of time required per iteration.

<sup>1</sup> It is understandable that a commercial tool would not want to publish its optimization techniques for protection reasons; this explains the rather low quality of the manual on theoretical background of the implemented algorithms in Optimus®

### 6.2.3 Convergence Improvement

The convergence of the optimization can be improved by using the best member of the population for generating each new member. The idea was adapted from **Shokhirev 2005**. This can be implemented by replacing Equation (6.1) with:

$$\begin{aligned} \vec{Y}_k &= \vec{A}_k + F \cdot (\vec{B}_k - \vec{C}_k) + KF \cdot (\vec{X}_{best_k} - \vec{A}_k) \\ y_i &= a_i + F \cdot (b_i - c_i) + KF \cdot (x_{best_k} - a_i), \quad i = 1 \dots n \end{aligned} \quad (6.4)$$

The impact of the best member of the population on the new members can be adjusted with a new control parameter, called  $KF$ , combination factor (not used by Optimus®). Its value has to be adapted to the characteristics of the objective function. Higher values of  $KF$  improve the convergence, but increase the risk of converging towards local optimal values.

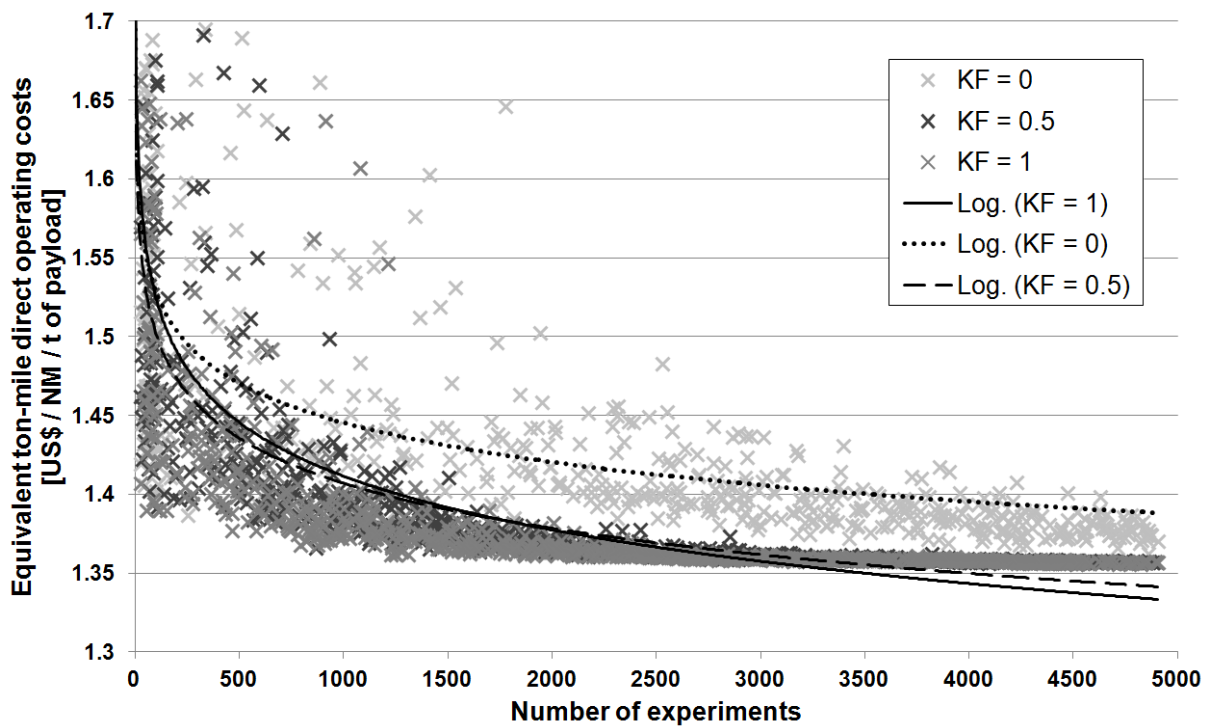

**Fig. 6.4** Impact of the combination factor  $KF$  on convergence

Figure 6.4 displays the results obtained in VBA for different  $KF$  factors, at the same weight factor of 0.7. Logarithmic trendlines are included for better visualization purposes. Values of the objective functions are given in Table 6.2.

$KF$	0	0.5	1
Best DOC	1.36237	1.35644	1.35569

A significant improvement in convergence and optimal value for the objective function was observed when increasing  $KF$  from 0 to 0.5 (see Table 6.2). As a downside, the calculation

time almost doubled due to the increased number of fitter members resulting from the crossover and the more frequent accessing of the computer memory. For example, the number of fitter members (or better candidates) obtained with  $KF = 0$  was 445, compared to 942 obtained for  $KF = 0.5$ . (The behavior of the algorithm with  $KF = 1$  is similar to  $KF = 0.5$ .)

The optimizations performed with DOC as objective function (for eleven variables<sup>1</sup>) indicated that it is very unlikely to converge towards local optimal values, so a more aggressive tuning of the algorithm parameters can be done. (This approach can be tested also for more sensible objective functions). If adapting not only the  $KF$ , but *also* the  $F$  control parameter as a next step, then, similar results are obtained (slightly even better) for half the number of iterations (and computation time) (see Table 6.3). In conclusion, the following table and chart indicate that *a well adapted choice of algorithm control parameters to the characteristics of the objective function can produce better results than the commercial software with its default algorithm control parameters.*

**Table 6.3** Impact of  $KF$  and  $F$  on the convergence

Algorithm	VBA		Optimus®
Parameter	KF=1 F=0.7	KF=1 F=0.25	KF=?? F=0.7
Number of function evaluations	4800	2400	2400
Best DOC	1.35569	1.35527	1.36237

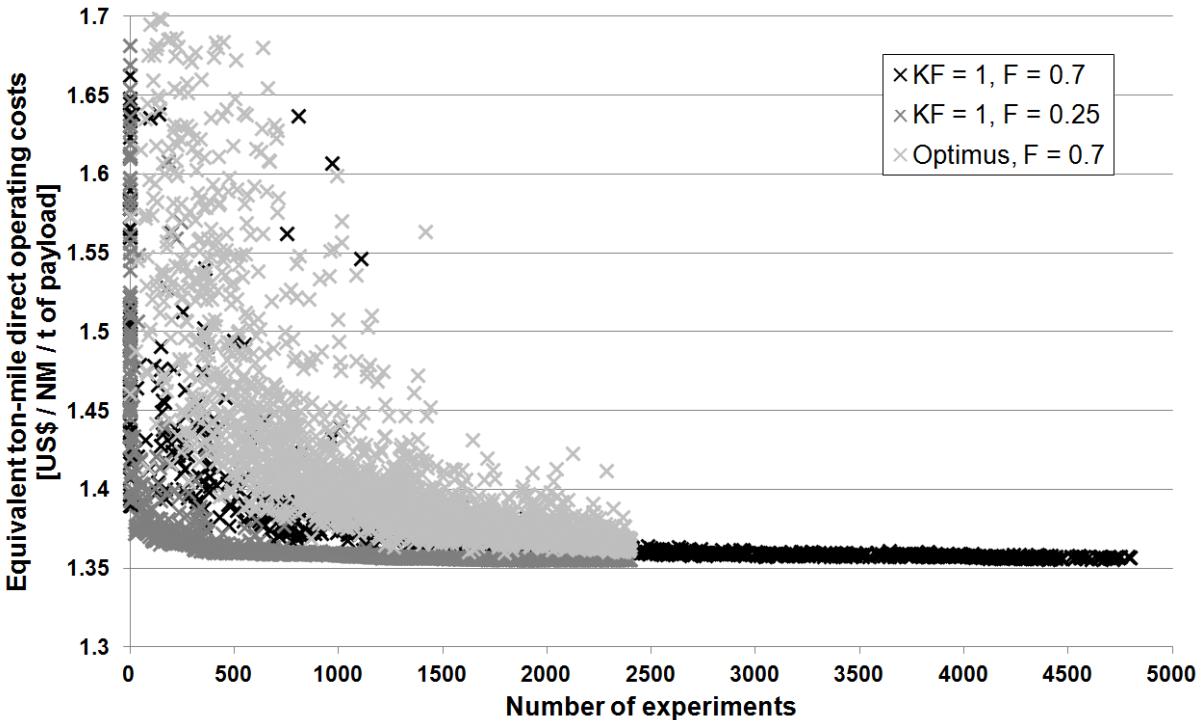

**Fig. 6.5** Impact of  $KF$  and  $F$  on the convergence

<sup>1</sup> The eleven variables are from case A19a-DOC, which is the most representative case that includes all aircraft design variables (see Section 9).



# 7 Description of OPerA: Tool for Preliminary Design and Optimization of Aircraft and Cabin Parameters

## 7.1 Spreadsheet Based Aircraft and Cabin Sizing

The tool developed to incorporate the discussed compendium of equations *from aircraft Preliminary Sizing to aircraft and cabin Preliminary Design and Optimization* is OPerA – *Optimization in Preliminary Aircraft Design*. The mission of OPerA is to allow a deep understanding of the design space and to support the aircraft designer to convert mission requirements into *optimized* aircraft parameters.

OPerA was also developed with the purpose to include cabin parameters into the optimization. The objective was to understand the contribution of cabin parameters to the optimal design. This objective is part of the pursuit of understanding to which extent the design philosophy “from inside out” would alter (or not) a design optimization based firstly on cost and secondly on performance. Currently the cabin represents the main criteria for an airline to differentiate itself among competitors. The cabin parameters can represent Added Values for the airline. An aircraft manufacturer should consider this already in the initial design phase<sup>1</sup>.

OPerA is part of an Aircraft Design *tool suite* that was developed at Hamburg University of Applied Sciences in *Microsoft Excel* (review Section 1.4.1): *SAS – Simple Aircraft Sizing*, allowing a manual analysis of basic Preliminary Sizing parameters; *OPerA – Optimization in Preliminary Aircraft Design*, allowing optimization of Conceptual Design parameters, and *PreSTo – Preliminary Sizing Tool*, allowing a modular, manual and more detailed approach of every Conceptual Design step.

Some of the reasons to select *Microsoft Excel* for building OPerA (and the tool suite it is part of) were its wide spread, its transparency, allowing the user to follow parameter interactions and to easily change equations. From the point of view of OPerA, additional reasons were the integration of *Visual Basic for Applications (VBA)* programming and especially the ability to interact with other software platforms, such as the high level optimization software *Optimus®*, created by Noesis Solutions, Belgium. Table 7.1 lists advantages and disadvantages of using Microsoft Excel.

---

<sup>1</sup> Sections 10 and 11 provide an in depth analysis of cabin related issues, from detailed cabin design up to the point when a cabin needs to be converted or upgraded. Section 11 shows a way to optimize cabin conversion processes.



**Table 7.1** Advantages and disadvantages of using MS Excel as a platform for developing OPerA  
Microsoft Excel as platform for developing OPerA

Advantages	Disadvantages
<ul style="list-style-type: none"> <li>• Programming of most of the calculations are possible and easier in a tabular form.</li> <li>• If more complicated algorithms are required, they can be built in a programming language, namely Visual Basic for Applications.</li> <li>• A tabular form allows many actions (the use of predefined functions, the selection of iterative calculations or the use of an equations solver).</li> <li>• Calculation and output are delivered efficiently in one step.</li> <li>• Parameters and their equations are easy to follow throughout the spreadsheet with an incorporated, automatic command.</li> <li>• The program can be connected to other useful software tools for Aircraft Design like CAD tools or optimization tools.</li> <li>• Includes other useful features like: <ul style="list-style-type: none"> <li>○ writing equations in an Equation Editor for an easier and faster understanding of the tabular variables;</li> <li>○ plotting of data in many available manners.</li> </ul> </li> <li>• MS Excel is available on almost all computers and known by most of the people.</li> <li>• The tool suite OPerA is part of is built in MS Excel, and this proved to be a successful choice (SAS has been used as a tool for students in the last 13 years).</li> <li>• Allows an easy intervention for changing or improving the tools like OPerA.</li> </ul>	<ul style="list-style-type: none"> <li>• It is slower for very difficult problems (not the case here).</li> <li>• There are limitations in performance and extendibility (e.g. maximum number of variables), which, nevertheless, have not been reached in OPerA.</li> </ul>

## 7.2 Description of OPerA – Optimization in Preliminary Aircraft Design

OPerA consists of:

- an Aircraft Design Model, according to the methodology explained in Sections 2, 3 and 4;
- an Optimization Module built in VBA, according to the selection performed in Section 4;
- an interface with a commercial optimization platform, Optimus®.

The tool was developed with the purpose to deliver pre-optimized Aircraft Design parameters for a later more detailed design (e.g. in PreSTo). It also offers the possibility of a complete, traceable design space investigation. This section presents the tool modules (tabs) and underlines certain particularities that were integrated for a streamlined and complete initial design generation and optimization. Figure 7.1 illustrates the structure of the tool.

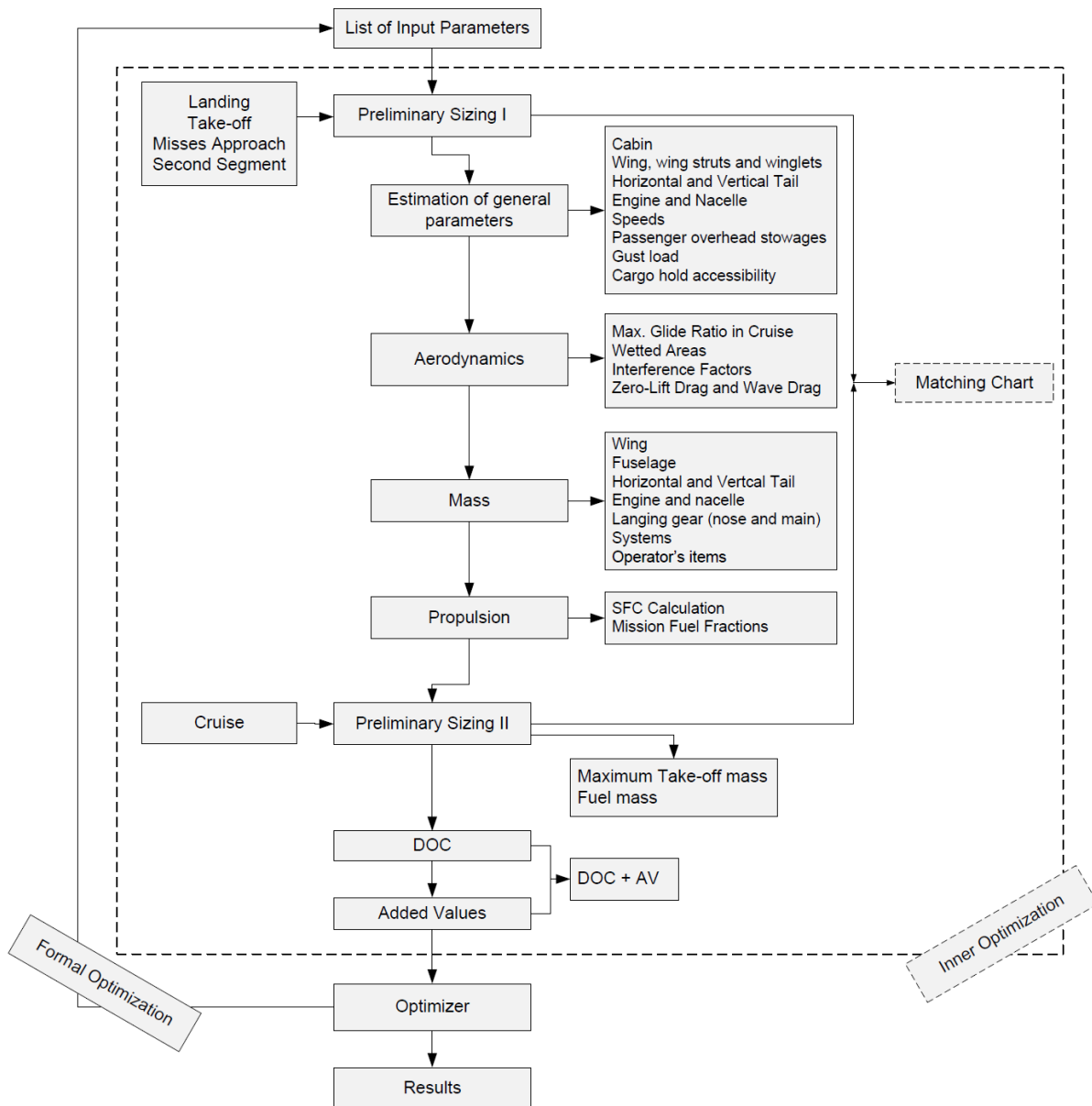

Fig. 7.1 Structure of OPerA

An *Input parameter page* gives an overview of the input parameters that are required as well as their type. There are either *user input* parameters (indicated with bold blue within the tool) and *experience-based* parameters (indicated with light blue). *All user input parameters become variables for optimization*. The experience based parameters represent rational inputs, most of the times based on own up-to-date statistics or expert knowledge. These values can be changed, but only if additional or different requirements are employed or if better references are found. Further on, OPerA contains the following modules:

- 1.) **Preliminary Sizing I** calculates, as in the SAS tool, the thrust-to-weight ratio,  $T/W$  and wing loading,  $m_{MTO}/S_W$  for Landing, Take-off, Missed Approach and Second Segment Climb requirements. Here main user inputs are landing field length,  $S_{LFL}$  and take-off field length,  $S_{TOFL}$ , lift coefficient in landing configuration,  $C_{LmaxL}$  and lift coefficient in take-off configuration,  $C_{LmaxTO}$ , aspect ratio,  $A$ , landing mass ratio,  $m_{ML} / m_{MTO}$ , number of

engines,  $n_E$ . These, along with other parameters are varied within the optimization process.

- 2.) **Estimation of General Parameters**, delivers most of the basic parameters that will be required for calculations in all the rest of the modules. Here all the main aircraft components are geometrically described. Additionally, some of the parameters bringing an Added Value to the airline are calculated for integration into a composed objective function (see Section 8). The described components are:
  - i. Cabin
  - ii. Wing
  - iii. Wing Struts (for the case of braced wing configuration)
  - iv. Winglets
  - v. Horizontal tail
  - vi. Vertical tail
  - vii. Engine and nacelle
  - viii. Speeds
  - ix. Passenger overhead stowage volume
  - x. Gust load
  - xi. Cargo hold accessibility
- 3.) **Max. Glide Ratio in Cruise**, delivers the Oswald factor and the maximum Lift-to-Drag ratio. It contains drag data, calculated within the module or taken from the Zero-Lift Drag Estimation module. Here the user has the possibility to set the level of accuracy and detail of drag estimation. For an easier understanding, it may be a good approach to firstly calculate aircraft drag simpler and as such with a less degree of parameters interrelation. Then, switching to more evolved drag estimation methods will help to understand the design space gradually. The different levels of drag estimation are explained in Table 7.2 at the end of this section.
- 4.) **Wetted Area Estimation**, performs a wetted area estimation that is later required to calculate zero lift drag, relative wetted area (total aircraft wetted area over wing area),  $S_{wet} / S_W$  and the interference drag. Wetted area estimation is also performed for a reference aircraft. In this module the relative wetted area  $S_{wet} / S_W$  is calculated and corrected according to the data of the reference aircraft (see Section 4.4).
- 5.) **Interference Factors**, delivers the interference drag coefficients for every aircraft component. For example, the nacelle interference factor is estimated for wing mounted engines, as a function of the distance between engine and wing. Other interference factors come from literature, as discussed in Section 2.2.
- 6.) **Zero-lift Drag Estimation**, contains the complete zero-lift drag estimation, based on friction coefficients, form factors, interference factors and wetted areas calculations. The

wave drag is not calculated but entered as a value taken from Aircraft Design experience. For a long range cruise Mach number, wave drag is accounted for with 10 counts. Additionally the proportion of Natural Laminar Flow that the wing may support is estimated. The total zero-lift drag is corrected based on the value from a reference aircraft (see Section 4.4). The calculated value for zero-lift drag from this module is handed back to module 3, where the user chooses the way maximum lift-to-drag ratio is calculated (see Table 7.2).

- 7.) **Mass Estimation**, contains the mass derivation for each of the main components and delivers the Operating Empty Mass of the aircraft design. Methods applied here are based on **Torenbeek 1986**, however, modifications were applied where considered necessary. Engine mass is calculated as a function of BPR from **Herrmann 2010**. Special attention was given to the landing gear mass estimation. The purpose was to include a model that delivered the mass as a function of the landing gear length. The only one found was from the German “Luftfahrttechnisches Handbuch“ (**LTH 2008**). The length of the nose landing gear and main landing gear is calculated such as to prevent tail strike or lateral tipping. The wing mass, calculated from **Torenbeek 1986**, contains a correction factor taking care of the general wing configuration. In this fashion also a braced wing configuration can be accounted for. The mass derivation also includes operator’s items, for which statistical data was taken from a document with Airbus-related parameters **AFPO 2006**.
- 8.) **SFC Calculation**, contains the specific fuel consumption (SFC) model from **Herrmann 2010** (see Section 2.2). Herrmann’s model was recently developed with the purpose to include higher by-pass ratios (BPR) engines. The model is based on **Torenbeek 1986** and was adapted to confidential data from Rolls Royce.
- 9.) **Preliminary Sizing II**, is similar to the ones in SAS or SAS Automated Matching. However, while for these tools the results were based on the simple calculation of relative Operating Empty Mass from **Loftin 1980**, here the relative Operating Empty Mass is taken from module 7, Mass Estimation. The check whether the resulting landing mass ratio is enough to accommodate fuel reserves becomes now a constraint for the optimization. An additional check is included: from the design point, the necessary fuel volume for the mission is calculated. From the wing geometry, the available fuel volume is estimated with **Torenbeek 1986** and corrected by two factors: one from CS 25.979(b) of 2 % and another one accounting for unusable fuel, of 3 %. This new check of assumptions is not a constraint; in the case that not enough fuel volume is available, the tool gives the user the hint to incorporate additional fuel tanks such as a center tank or a tank in the horizontal tail during later detailed design.

- 10.) **Matching Chart**, gives the 2D representation of the five requirements and the design point. This allows the visualization of the way requirements match. By automatically finding the design point in the matching chart, an *inner optimization* is performed.
- 11.) **DOC**, produces the results of the Direct Operating Costs (DOC) calculation, after the method of Association of European Airlines (**AEA 1989a**, **AEA 1989b**). DOCs are taken as an objective function on their own, or combined with Added Values from module 12. The module calculates absolute costs: depreciation, interest, insurance, fuel, maintenance, crew, fees, but also relative costs, among which the *equivalent-ton-mile-costs* are the most relevant for this study.
- 12.) **Added Values**, gathers those parameters that bring an Added Value for the airline. The Added Values are added to the weighted economics of the aircraft DOC expressed as equivalent-ton-mile-costs. The weights of the DOC and all Added Values are input parameters in OPerA and are the result of an expert questioning. The weights should only be changed if for better reasons other weights have been formally obtained. Low and high limits were set for each of the Added Values. These limits may be different for short, medium and long range aircraft. In between the limits, the source on each Added Value and the DOC is linearly assigned. A score is calculated for each set of input parameters and hence for each design iteration during optimization (more details in Section 8).
- 13.) **Optimization Set-up**, gives the user the possibility to perform optimizations, either with OPerA's own optimization algorithms or with Optimus® via an *Add-In* connection. Here the user needs to set low and high boundaries for each parameter that he chooses to vary. For the implemented algorithms in OPerA (*Differential Evolution* and *DOE Diagonal*), the user must select which parameters are included in the optimization from a *Yes / No* dropdown box for each variable. In the same way objectives are selected. Also, the user needs to establish certain control parameters, such as number of iterations, population size or cross-over rate (see Sections 5 and 6 for the theoretical background of the algorithms implemented in OPerA). Hints, aiding the user, are given in the form of comments. Once the set-up is complete, the algorithms are initiated via command buttons, which the user simply needs to press. For manual optimization additional command buttons are set for finding the design point and for parameter re-initialization (required for stability reasons, as explained in Section 4.4). This tab also displays the matching chart. While experiments run, the user can see the "live" movement of the lines for each requirement in the matching chart in search of the optimal design point.
- 14.) **Results DE**, automatically displays the results produced with the incorporated Differential Evolution algorithm, created for multiple parameter variations.
- 15.) **Results DOE Diagonal**, automatically displays the results produced with the incorporated DOE Diagonal algorithm, created for single parameter variations.

The tool contains two additional sheets: one for information purposes, that gathers statistical data or additional factor calculations, called **Other Sources** and another one used to automatically find the design point, with which the user, in general, should not interfere. The only place where the user might need to make adjustments (for stability reasons mostly), is in the cells where the lower and upper boundaries for the  $V / V_{md}$  ratio are set. This sheet is called **Choosing the Design Point**<sup>1</sup>.

As mentioned before, Table 7.2 illustrates the cases in which  $E_{max}$  can be calculated (either with Equation (7.1) or with Equation (7.2), depending on the case). This approach allows minimizing or maximizing the degree of accuracy during the calculations. A more accurate calculation involves more complex parameter relations and it may turn to be difficult to assess results. The user can select the case he wants to use for the calculations. The most accurate case is *D2*, while the least accurate is case *A1*.

$$E_{max} = \frac{1}{2} \sqrt{\frac{\pi \cdot A \cdot e}{C_{D,0}}} \quad \text{or} \quad C_{D,0} = \frac{\pi \cdot A \cdot e}{4 \cdot E_{max}^2} \quad (7.1)$$

$$E_{max} = k_E \sqrt{\frac{A}{S_{wet} / S_W}}; \quad k_E = \frac{1}{2} \sqrt{\frac{\pi \cdot e}{c_f}} \quad (7.2)$$

**Table 7.2** Possible combination cases for estimating  $E_{max}$  implemented in OPerA

Oswald factor, e	$S_{wet}/S_W$		$C_{D,0}$	
	Statistics	Calculated	Q correction	Full $C_{D,0}$ calculation
	Case A	Case B	Case C	Case D
Statistics - Case 1	Case A1	Case B1	Case C-A1	Case D1
			Case C-B1	
Calculated - Case 2	Case A2	Case B2	Case C-A2	Case D2
			Case C-B2	
Zero-Lift Drag coefficients used to calculated cases C and D				
Statistics - Case 1	$C_{D,0,prel}, A1$	$C_{D,0,prel}, B1$	$C_{D,0,interf}, A1$	$C_{D,0}, D1, D2$
			$C_{D,0,interf}, B1$	
Calculated - Case 2	$C_{D,0,prel}, A2$	$C_{D,0,prel}, B2$	$C_{D,0,interf}, A2$	
			$C_{D,0,interf}, B2$	

<sup>1</sup> The user should be aware that any change in the names of the tabs requires adjustments in the VBA code. Changing the names without adjusting the codes, leads to malfunctions.

## 7.3 Optimization with OPerA

The *Optimization Module* in OPerA makes two approaches available for the user:

- 1.) Utilization of command buttons, which call the OPerA built-in algorithms in VBA.
- 2.) Utilization of the interface with the commercial optimization platform, Optimus®.

By creating the Optimization Module in OPerA, which is founded on the traditional approach to Aircraft Design, the 2D optimization of the matching chart is embedded into the formal optimization (see Figure 7.2).

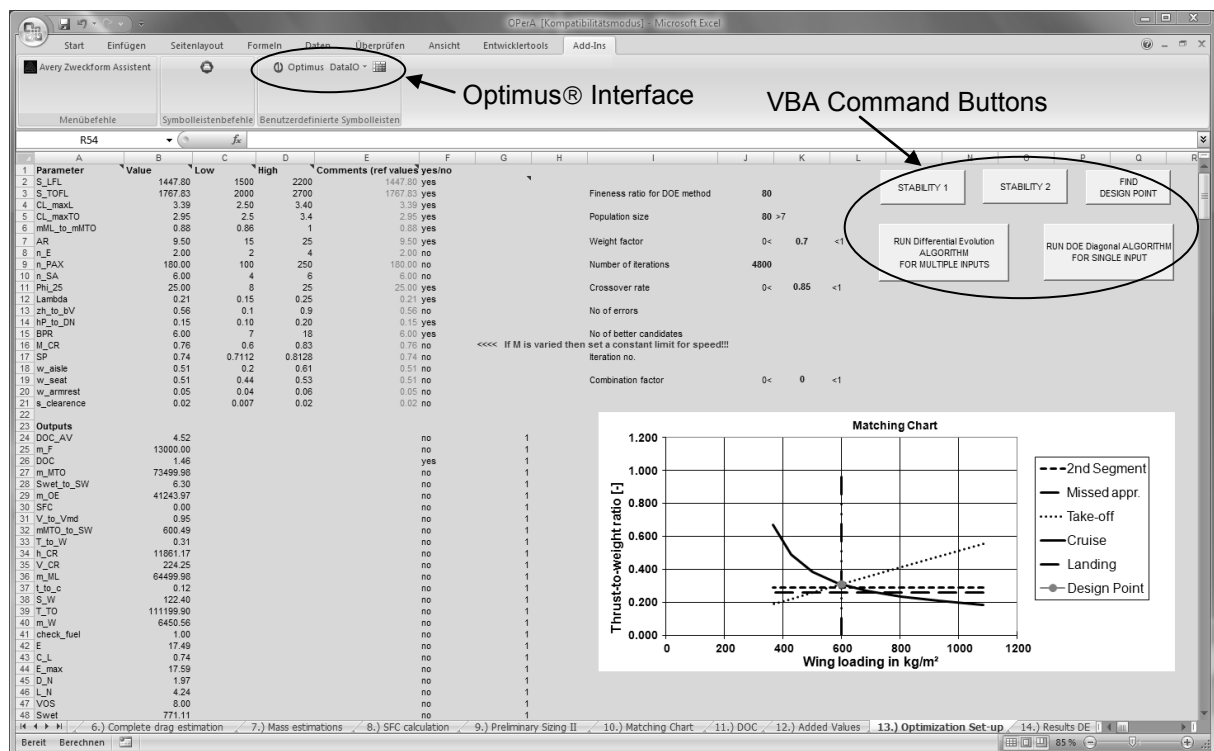

Fig. 7.2 “Optimization Set-up” module in OPerA with two optimization approaches

This approach allows the results to be *traceable*. It also allows *design exploration* and *parameter studies* that enable the overall understanding of the parameter behavior and, eventually, an overall optimization with all parameters subject to optimization delivering the ultimate optimum of the design.

So, the goal is to apply formal optimization of Aircraft Design parameters already in the initial stage of Preliminary Sizing and Conceptual Design and to offer it as a starting point for further interactive parameter changes in a more detailed design step.

### 7.3.1 The VBA Module

The first approach – utilization of built-in command buttons that call the programmed algorithms in VBA – is of great importance for OPerA, because it enables it to function independently from any optimization toolbox or software. There are 5 command buttons, but only two of them, corresponding to each of the two selected algorithms, are part of the Optimization Module (“Run Differential Evolution Algorithm for Multiple Input” and “Run DOE Diagonal Algorithm for Single Input”). The rest of the three buttons (“Find Design point”, “Stability 1” and “Stability 2”) are programmed for finding the design point automatically and for stabilizing the tool (see Figure 7.2 and Section 4).

Before pressing one of the two command buttons that initialize the optimization process, the user needs to:

- set up the control parameters (population size, number of iterations, weight factor, cross-over rate and combination factor) (see Section 6.2);
- select the free parameters (among the 20 available);
- select the objective function (displayed as outputs).

In case of faulty selections or assignments the tool displays corresponding error messages. The calculation only starts if the set-up is complete and correct.

In order to reduce calculation time and improve robustness, it is recommended to adjust the low and high boundaries towards the smallest possible design space, yet without endangering the finding of the solution. For this reason, step by step optimization, starting from a smaller amount of parameters, could help the user to identify accurately the design space, and streamline his calculation process.

### 7.3.2 The Connection with Optimus®

The second approach – utilization of the interface with Optimus® – was initially implemented to rapidly test the way equations in OPerA behave as a whole, and, as such, to validate the tool before creating the VBA module. The differences concerning the results between the two approaches were discussed in Section 6. An advantage of using Optimus® instead of the VBA algorithm is its display characteristics of the results, allowing a more user friendly design exploration.

The implementation of Optimus® in OPerA is performed via an *Add-In*. The Add-In was created by Optimus® to enable the creation of Optimus® projects for specific Excel calculations. The Add-In also allows to import and export results between the different codes



or to color the results in Excel identical to the plots in Optimus®. This Add-In is only available on Microsoft Windows operating systems and supports MS Excel 2002 or higher. The Add-in is not activated during the installation of Optimus®; the user has to activate it as any other Add-In in Excel. The file is called OptimusUtilities.xla and is accessed via the Browse function in Excel.

To access the Optimus® interface in Excel, the Optimus® button needs to be pressed (see screenshot in Figure 7.3). A window opens, as in Figure 7.4. The free parameters and the outputs need to be selected prior to pressing the interface button, so that they are shown in the window. Macros appear automatically. The user needs to then select the inputs, outputs and the macros in the order he wishes them to run.

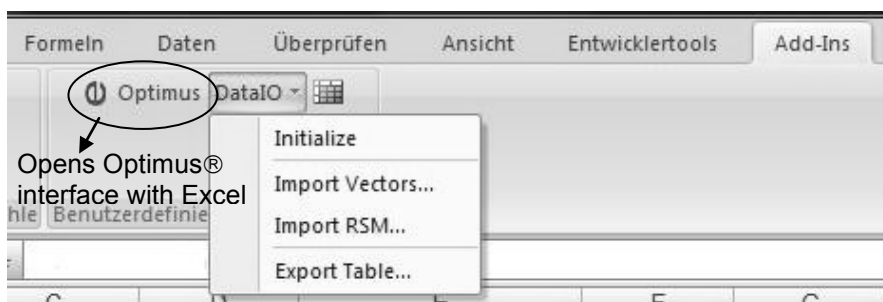

**Fig. 7.3** The Optimus® toolbar in Excel and the Data IO menu

The Data IO menu has several functions which allow: setting up the Excel sheet (through the “Initialize” button), import vectors or Response Surface Models from Optimus®, or export tables from Excel into the Optimus® table format, for performing further evaluations.

The condition for the Add-in to work is to previously have automatic calculations turned on in Excel. If macros are used, the “Trust access to Visual Basic Projects” option in Excel Security needs to be checked.

### 7.3.3 The MS Excel Solver

The “Find Design Point” button is the button through which the design point is automatically found and handed over for further calculation in Preliminary Sizing II module. The philosophy of finding the design point is based on the idea that the cruise and landing lines should be part of the design point no matter what. Hence, the intersection of the cruise line with the point of maximum abscise given by the landing line intersecting one of the rest of the requirements, needs to be found for each set of new parameters. Solving the equation of the intersection point between Cruise and (Landing + Take-off) or Cruise and (Landing + 2<sup>nd</sup> Segment) or Cruise and (Landing + Missed Approach) would be a very difficult task without the use of the *MS Excel Solver*.

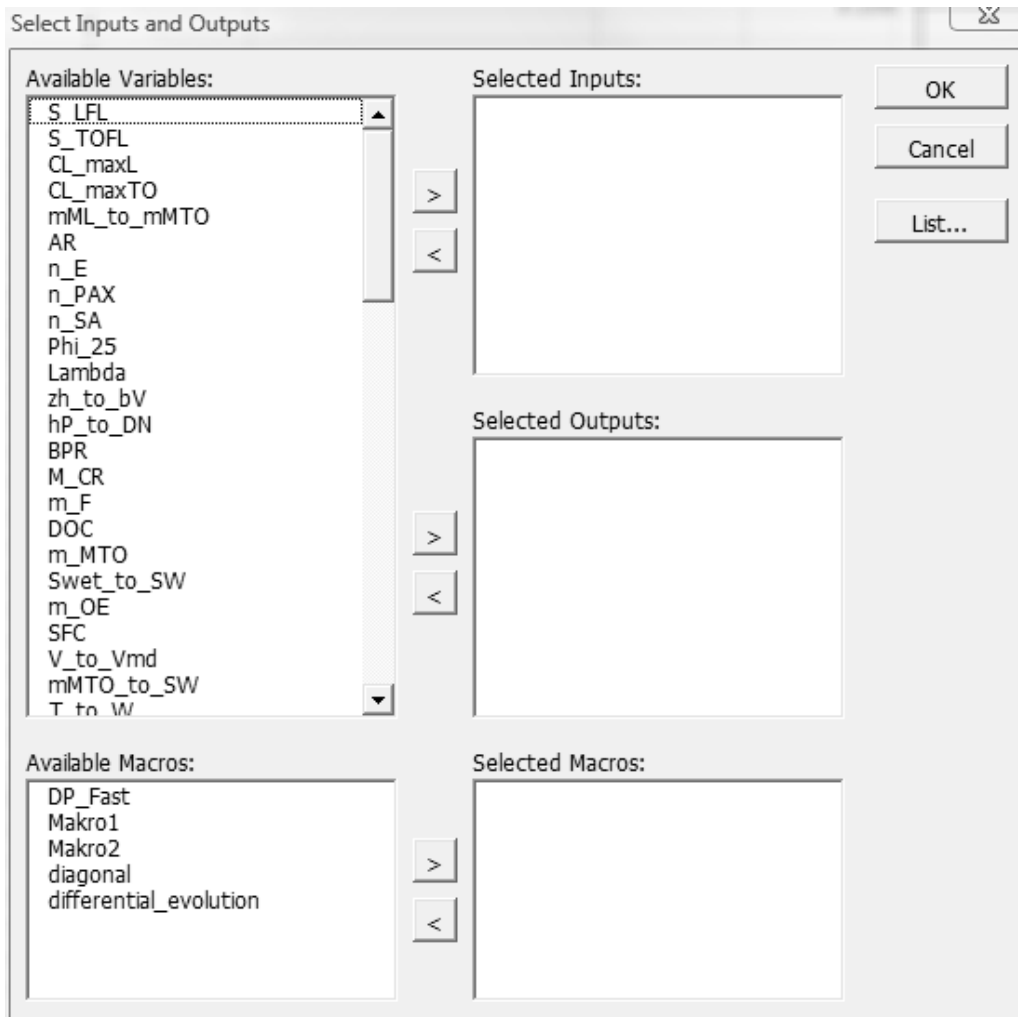

**Fig. 7.4** The Excel interface with Optimus®

The question arises: would MS Excel Solver alone suffice for solving the entire optimization problem in OPerA? Is there a less complicated solution, available already in MS Excel, that would eliminate the need to program an own algorithm in VBA?

The MS Excel Solver minimizes or maximizes the value of a parameter or an equation depending on a limited amount of adjustable cells:

*With Solver, you can find an optimal value for a formula in one cell – called the target cell – on a worksheet. Solver works with a group of cells that are related, either directly or indirectly, to the formula in the target cell. Solver adjusts the values in the changing cells that you specify – called the adjustable cells – to produce the result that you specify from the target cell formula. You can apply constraints to restrict the values that Solver can use in the model, and the constraints can refer to other cells that affect the target cell formula (Excel 2011a).*

The number of adjustable cells in Excel Solver is limited to 200 (Excel 2011a).

For non-linear problems, the MS Excel Solver uses the Generalized Reduced Gradient (GRG2) nonlinear optimization code, which was developed by Leon Lasdon, University of

Texas at Austin, and Alan Waren, Cleveland State University (**Excel 2011b**). A description of the basic GRG algorithm can be found in **Lasdon 1974**. This algorithm uses gradient information: partial derivatives measure the rate of change in the cells and give hints about how the adjustable cells should be varied.

There were no attempts to build (or rebuild) OPerA so as to perform the Aircraft Design Optimization with the Excel Solver. The main reason was the decision to use evolutionary algorithms for the optimization, instead of gradient based. Using MS Excel Solver would be more appropriate for simpler optimization problems – for tools at the level of SAS: Simple Aircraft Sizing.

# 8 Objective Functions

## 8.1 Classical Objectives

Three single objectives are minimized:

- *maximum take-off mass*,  $m_{MTO}$ ,
- *fuel mass*,  $m_F$ ,
- Direct Operating Costs (DOC) expressed as *equivalent ton-mile cost*,  $C_{equiv,t,m}$ .

Minimum  $m_{MTO}$  is a classical objective in Aircraft Design (a recent example in Aircraft Design research community:  $m_{MTO}$  has been chosen as objective for all research on optimization at Multidisciplinary Analysis and Design (MAD) Center for Advanced Vehicles of Virginia Tech (MAD 2011, Gundlach 2000, Gundlach 1999, Gern 2005).

Nevertheless, that costs are the most important criteria in Aircraft Design Optimization has been confirmed not only by literature (Schmitt 2009), but also by aircraft designs that were aborted due to economical inefficiency (e.g. Concorde).

For a design taking account of the environment, minimizing fuel mass is a suitable objective. Minimizing fuel mass works positive in two directions:

- fuel is saved to make as much use of running out fossil fuels and is less demanding on new fuel alternatives,
- fuel is saved to produce in proportion also less CO<sub>2</sub> and as such also less global warming.

One of the results of this work is the conclusion that currently, fuel savings are only a secondary effect of DOC optimizations.

DOCs are calculated with standard methodologies. Here applied is the DOC method of the Association of European Airlines from 1989 (AEA 1989a, AEA 1989b), for a typical medium range mission of 750 NM (London - Rome). An extended DOC objective function that would account for noise and pollutant emission costs plus standard DOC is *currently* inappropriate in Aircraft Design. Current average noise fees and pollution fees have little influence on the overall economics of aircraft (Johanning 2012) because these fees are very small. Taking the example of the A320 aircraft on a world average today only 0.021 % of the extended DOC are for noise costs, and only 0.002 % (!) for pollution costs. These current measures are not enough to encourage designers to change the way they optimize aircraft, despite the declared objectives of the Advisory Council for Aeronautical Research in Europe (ACARE) (ACARE 2011).

## 8.2 Added Values in Aircraft Design Optimization

Since currently economics are the most important driver in Aircraft Design Optimization, the question is born: How can an aircraft increase its profitability, once it has been optimized for DOC? More precisely: What are the parameters that could bring an *Added Value* to the airline, and allow it, in turn, to produce more revenue? The idea of evaluating “Added Values” came from **Meller 1998** and **Chen 1998**. Meller underlines that, in addition to economics, also aspects like performance, operating flexibility, commonality or comfort, become important for *competitive positioning*. He states that often aircraft are perceived by the airlines as providing comparable levels of technology and therefore no longer offer distinct advantages in Direct Operating Cost. He proposes the implication of Added Values (AV) *within* the design *evaluation* process. Both Meller and Chen used this approach for *aircraft comparisons*, in order to determine distinct advantages that an aircraft may have against its competitor.

Here, Added Values are included in an objective function, together with DOC, in order to assess their impact on a *new* design and optimize the design accordingly.

The selection of the Added Values was made in conjunction with Chen and Meller’s hints and own considerations (having in mind also the tool’s capabilities). They are listed and commented on in Table 8.1. Some remarks:

- Landing field length results from optimization to be smaller than the take-off field length (due to different lift characteristics for take-off and landing). This is why it is not included as an Added Value<sup>1</sup>.
- Sidewall clearance is defined as the clearance between the armrest and the sidewall. It results from cabin design as indicated in Figure 8.1. Critical points (cross points in Figure 8.1) have all to be inside a defined valid inner cabin contour. The minimum value for the sidewall clearance results from one of the critical points directly on the cabin contour. This sidewall clearance does not score for Added Values. If however a larger sidewall clearance is chosen producing additional head or shoulder clearance and comfort, Added Values are scored.

---

<sup>1</sup> The reader will see in Table 8.10 that the final weighting attributed to this Added Value is 0.

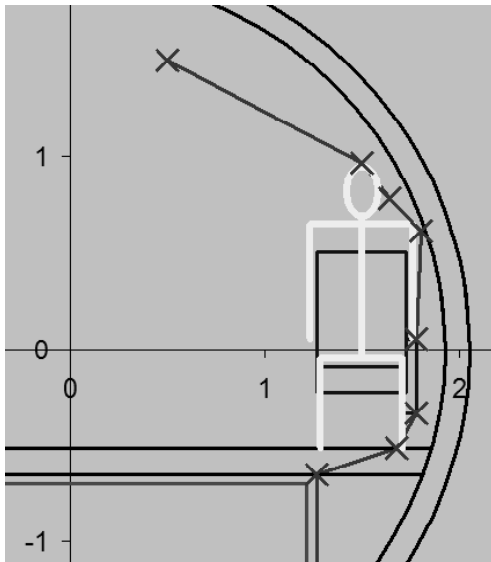

**Fig. 8.1** Sidewall clearance: Clearance between armrest and sidewall. Graphic extracted from *PreSTo*.

**Table 8.1** Added Values selected for inclusion in OPerA

Economics (represented by equivalent-ton-mile costs)				
Added Values	Performance	Airport Performance	Take-off field length <sup>1</sup>	
			Relative landing mass ratio <sup>2</sup>	
		Cruise Performance	Cruise speed <sup>3</sup>	
	Passenger Comfort	Concerning all passengers		Seat Pitch <sup>4</sup>
				Seat width <sup>5</sup>
				Armrest width <sup>6</sup>
				Aisle width <sup>7</sup>
				Aisle height <sup>8</sup>
				Overhead bin volume per pax <sup>9</sup>
				Aircraft gust sensitivity <sup>10</sup>
	Cargo handling	Concerning part of the passengers		Sidewall clearance <sup>11</sup>
				Number of "excuse-me seats" <sup>12</sup>
		Concerning Cargo		Containerized cargo (yes / no) <sup>13</sup>
	Concerning working conditions		Accessibility factor <sup>14</sup>	
			Cargo compartment height <sup>15</sup>	
Comments	<sup>1</sup> Ability to take-off and land on small airfields <sup>2</sup> Ability to land with much fuel reserve; possibility for fuel tankering <sup>3</sup> Short flying time <sup>4</sup> Much space for legs <sup>5</sup> Comfortable seating (referring to seat cushion) <sup>6</sup> Comfortable arm resting and separation from neighbor <sup>7</sup> Easy boarding and de-boarding; bypassing a trolley in the aisle <sup>8</sup> Sufficient height for upright standing position <sup>9</sup> Sufficient volume for carry-on baggage <sup>10</sup> Flight through gusts should cause only small changes in load factor <sup>11</sup> Size of gap between armrest and sidewall <sup>12</sup> Minimum number of seats that require the permission of two passengers to get to the aisle (window seats are not considered "excuse-me" seats) <sup>13</sup> Easy loading of cargo <sup>14</sup> Important measure for working conditions for ground operation (accessible cargo door for loading and unloading); sill height and cargo door height are considered <sup>15</sup> Important measure for working condition within the cargo compartment			

In order to build the objective function, Added Values need to be weighted: their importance needs to be evaluated compared to other aircraft parameters and economics (DOC).

For setting weightings as correctly as possible, a *questionnaire* for Added Values (AV) in Aircraft Design was filled out independently by a group of people formed by experts, PhD students and students. The questionnaire (see Appendix B) consisted of two pages: On page 1 a Hierarchical Table with a hierarchical break-down of attributes, with percents summing up to 100 % for each break-down was used. On page 2 a matrix, representing the base for an Analytic Hierarchy Process (AHP), where degrees of importance for each Added Value are set.

### 8.2.1 Low and High Boundaries of Added Values

Even before setting the *weights*, for a proper Added Value assessment, low and high boundaries for each Added Value needed to be rationally set (for each type of aircraft – short, medium or long range). Depending on the Added Value parameter, a maximum of 10 *points* were attributed for minimal or maximal values. For example, DOC receive the maximum of 10 points for a minimal value, while 10 points are given for maximal cruise speed, which favors a short flying time, and a flight altitude for which gust sensitivity is small. The distribution of points between boundaries is linear, according to Figure 8.2. The resulting points are later multiplied with the weights and a *score* results, which goes into the objective function.

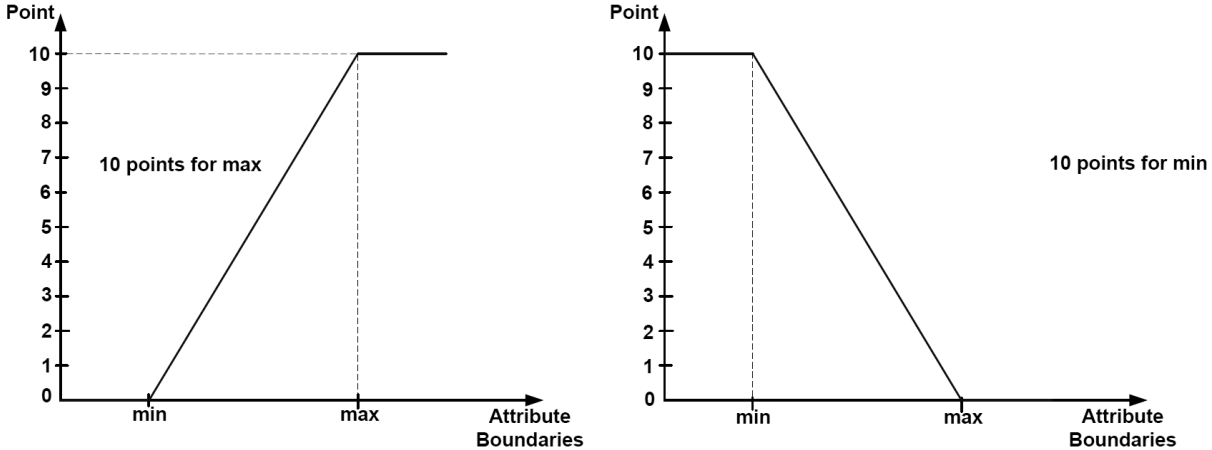

**Fig. 8.2** Conversion of optimization values into points

A few examples of Added Value limitations and the way points are assigned to the resulting optimization value are given in Table 8.2.

**Table 8.2** Examples of Added Values boundaries

Example of Added Value	Low limit	High limit	Resulting point
Aisle height	Min = 1.75 m	Max = 2.10 m	<i>if Value &lt; Min, then 0 points</i> <i>if Value &gt; Max, then 10 points</i> <i>otherwise: Value = 10 · <math>\frac{Value - Min}{Max - Min}</math></i>
Take-off field length	Min = 1670 m	Max = 2700 m	<i>if Value &lt; Min then 10 points</i> <i>if Value &gt; Max, then 0 points</i> <i>otherwise: Value = 10 · <math>\frac{Value - Max}{Max - Min}</math></i>
Containerized cargo	Yes	No	<i>if Value = Yes, then 10 points</i> <i>if Value = No, then 0 points</i>

Most of the Added Value boundaries are different depending if the aircraft is designed for short, medium or long range. For example, take-off field length boundaries in Table 8.2 are suitable for a medium range aircraft. For a short range aircraft, these boundaries should be smaller: they may be selected between 1200 m and 2200 m. A long range aircraft can have boundaries of 1600 m, respectively 3500 m. These limitations were set by looking at existing aircraft.

Boundaries of Direct Operating Costs are also different depending on the type of aircraft. The low boundary was set by calculating DOC for a maximum number of passengers and high cruise speed, while the high boundary was calculated for a minimum number of passengers and low cruise speed.

## 8.2.2 Questionnaires Evaluation

Each page of every questionnaire was evaluated, comparisons of assigned weights between the two pages were made and consistency checks were performed. Helpful literature sources were found to be **Saaty 1990**, **Miller 1956** and **Alonso 2006**.

From the Hierarchical Table (page 1) the resulting absolute weights were calculated. This was done for each participant. Averages were calculated for experts, PhD students, students and averages for all participants.

The AHP matrix from page 2 was evaluated and compared to the results from the Hierarchical Table from page 1. Existing scientific evaluation methods were applied. It was found that for square matrices larger than 9, it is rather difficult for the experts working on the questionnaire to handle the information (compare with **Saaty 1990** and **Miller 1956**). A matrix for  $n$  parameters requires  $m$  individual evaluations to be done by the expert:

$$m = (n^2 - n) / 2 \quad . \quad (8.1)$$



This function is plotted in Figure 8.3. A matrix with, for example  $n = 16$  parameters requires  $m = (n^2 - n) / 2 = 120$  evaluations, which is far too much work for an evaluator and not very practical.

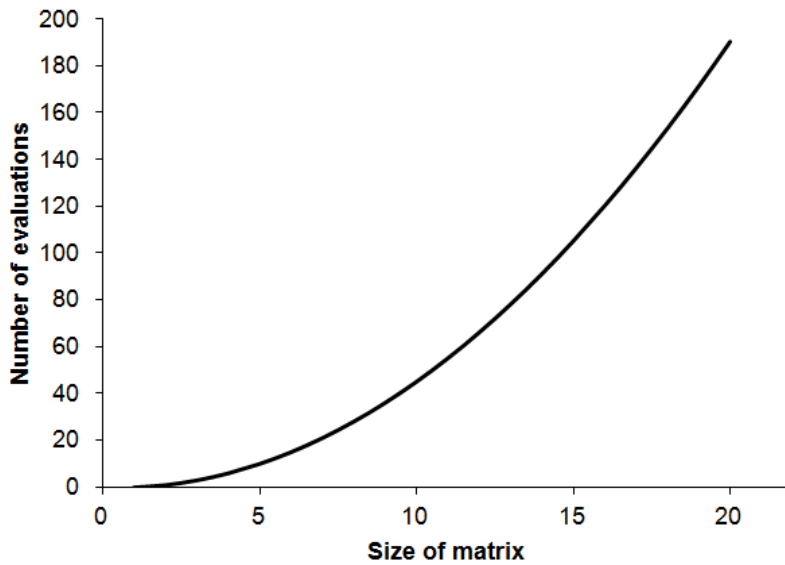

**Fig. 8.3** Required number of evaluations as a function of the size of the matrix

### Consistency Check

User input from page 1 cannot be checked on its own. However, a consistency check is possible and can be performed on the matrix of page 2. According to **Saaty 1990**, a matrix consistency index can be defined as:

$$CI = \frac{\lambda_{max} - n}{n - 1} , \quad (8.2)$$

where  $n$  is the size of the matrix and  $\lambda_{max}$  is the principal eigenvalue of the matrix from

$$Aw = \lambda_{max} w , \quad (8.3)$$

with the weighting vector  $w$ .

In case of full consistency  $\lambda_{max} = n$  and  $CI = 0$ . Otherwise  $CI \geq 0$  because the principal eigenvalue  $\lambda_{max} \geq n$  (**Saaty 1990**).

For calculating the *principal eigenvalue* for such a large matrix (of e. g.  $n = 16$ ) a simple approximate method is applied. It is based on the *normalized reciprocal matrix* of the given matrix (see example in Figure 8.4). The reciprocal matrix is built by transposing the linear scale from 1 to 10 that the experts used to fill in the matrix, to a reciprocal scale from 1 to 9. This scale is indicated in Table 8.3.

**Table 8.3** Linear scale and reciprocal scale

linear scale up to 10	reciprocal scale
0	0.111
1	0.135
2	0.172
3	0.238
4	0.385
5	1.000
6	2.600
7	4.200
8	5.800
9	7.400
10	9.000

**Table 8.4** Normalized eigenvector for the example matrix in Fig. 3

approximate method	exact method (MATLAB®)
8.7 %	8.6%
8.7 %	8.6%
2.9 %	2.7%
17.6 %	18.4%
19.4 %	20.0%
8.7 %	8.8%
2.9 %	2.7%
1.6 %	1.5%
1.6 %	1.5%
7.1 %	7.0%
3.0 %	2.8%
0.8 %	0.8%
4.8 %	4.5%
9.0 %	9.2%
1.5 %	1.5%
1.5 %	1.5%

In this simple approach the *eigenvector* is given by the averages of each line of the normalized reciprocal matrix. For example, the first element of the eigenvector is given by the average of the first line. The eigenvector for the matrix in Figure 8.4 is given in Table 8.4. The principal eigenvalue is calculated as the sum of the products between each element of the eigenvector and the sum of elements from the corresponding column in the reciprocal matrix. For the example in Figure 8.4, the principal eigenvalue has the value of 17.9 (see example calculation in Equation 8.4).

$$\lambda_{max} = (13.7 \cdot 8.7 \%) + (13.7 \cdot 8.7 \%) + (41.5 \cdot 2.9 \%) + (6 \cdot 17.6 \%) + \dots + (58.6 \cdot 1.5 \%) = 17.9 \quad (8.4)$$

The exact calculation of the principle eigenvalue and eigenvector requires much more steps in the calculation. A tool like MATLAB® allows an easy approach to such an exact calculation. For the same matrix, the method given by MATLAB® delivers a value of 17.29 for the principal eigenvalue. The eigenvector is given in Table 8.4. The small deviation, of only 2.9 % between the approximate and the exact calculation of the principle eigenvalue shows the suitability of the simpler method for the evaluation of the questionnaire. The advantage of the simpler method lies in the fact that it can easily be incorporated in any spreadsheet, even if matrix calculations are not possible.

Example Matrix		B															
		Landing field length	Take-off field length	Relative landing weight ( $m_{ML}/m_{MTO}$ )	Cruise speed	Seat pitch	Seat width	Armrest width	Aisle width	Aisle height	Overhead bin volume per pax	Aircraft gust sensibility	Sidewall clearance	Number of "excuse-me" seats	Containerized cargo (yes/no)	Accessibility factor	Cargo compartment height
A	↑	1	2	3	4	5	6	7	8	9	10	11	12	13	14	15	16
Landing field length	1	5	7	5	3	4	7	8	8	5	7	10	6	5	8	8	
Take-off field length	2	5	7	5	3	4	7	8	8	5	7	10	6	5	8	8	
Relative landing weight ( $m_{ML}/m_{MTO}$ )	3	3	3	3	1	2	5	6	6	3	5	8	4	3	6	6	
Cruise speed	4	5	5	7	5	6	9	10	10	10	9	10	8	7	10	10	
Seat pitch	5	7	7	9	5	6	9	10	9	7	9	10	8	7	10	10	
Seat width	6	6	6	8	4	4	6	7	7	5	6	9	6	4	7	7	
Armrest width	7	3	3	5	1	1	4	6	6	3	5	8	4	3	6	6	
Aisle width	8	2	2	4	0	0	3	4	5	2	4	7	3	2	5	5	
Aisle height	9	2	2	4	0	1	3	4	5	2	4	7	3	2	5	5	
Overhead bin volume per pax	10	5	5	7	0	3	5	7	8	8	6	9	6	4	7	7	
Aircraft gust sensibility	11	3	3	5	1	1	4	5	6	6	4	8	4	3	6	6	
Sidewall clearance	12	0	0	2	0	0	1	2	3	3	1	2	2	1	4	4	
Number of "excuse-me" seats	13	4	4	6	2	2	4	6	7	7	4	6	8	4	7	7	
Containerized cargo (yes/no)	14	5	5	7	3	3	6	7	8	8	6	7	9	6	7	7	
Accessibility factor	15	2	2	4	0	0	3	4	5	5	3	4	6	3	3	5	
Cargo compartment height	16	2	2	4	0	0	3	4	5	5	3	4	6	3	3	5	

Reciprocal Matrix		B															
		1	2	3	4	5	6	7	8	9	10	11	12	13	14	15	16
1	1.0	1.0	4.2	1.0	0.2	0.4	4.2	5.8	5.8	1.0	4.2	9.0	2.6	1.0	5.8	5.8	
2	1.0	1.0	4.2	1.0	0.2	0.4	4.2	5.8	5.8	1.0	4.2	9.0	2.6	1.0	5.8	5.8	
3	0.2	0.2	1.0	0.2	0.1	0.2	1.0	2.6	2.6	0.2	1.0	5.8	0.4	0.2	2.6	2.6	
4	1.0	1.0	4.2	1.0	1.0	2.6	7.4	9.0	9.0	9.0	7.4	9.0	5.8	4.2	9.0	9.0	
5	4.2	4.2	7.4	1.0	1.0	2.6	7.4	9.0	7.4	4.2	7.4	9.0	5.8	4.2	9.0	9.0	
6	2.6	2.6	5.8	0.4	0.4	1.0	2.6	4.2	4.2	1.0	2.6	7.4	2.6	0.4	4.2	4.2	
7	0.2	0.2	1.0	0.1	0.1	0.4	1.0	2.6	2.6	0.2	1.0	5.8	0.4	0.2	2.6	2.6	
8	0.2	0.2	0.4	0.1	0.1	0.2	0.4	1.0	1.0	0.2	0.4	4.2	0.2	0.2	1.0	1.0	
9	0.2	0.2	0.4	0.1	0.1	0.2	0.4	1.0	1.0	0.2	0.4	4.2	0.2	0.2	1.0	1.0	
10	1.0	1.0	4.2	0.1	0.2	1.0	4.2	5.8	5.8	1.0	2.6	7.4	2.6	0.4	4.2	4.2	
11	0.2	0.2	1.0	0.1	0.1	0.4	1.0	2.6	2.6	0.4	1.0	5.8	0.4	0.2	2.6	2.6	
12	0.1	0.1	0.2	0.1	0.1	0.1	0.2	0.2	0.2	0.1	0.2	1.0	0.2	0.1	0.4	0.4	
13	0.4	0.4	2.6	0.2	0.2	0.4	2.6	4.2	4.2	0.4	2.6	5.8	1.0	0.4	4.2	4.2	
14	1.0	1.0	4.2	0.2	0.2	2.6	4.2	5.8	5.8	2.6	4.2	7.4	2.6	1.0	4.2	4.2	
15	0.2	0.2	0.4	0.1	0.1	0.2	0.4	1.0	1.0	0.2	0.4	2.6	0.2	0.2	1.0	1.0	
16	0.2	0.2	0.4	0.1	0.1	0.2	0.4	1.0	1.0	0.2	0.4	2.6	0.2	0.2	1.0	1.0	
sum		13.7	13.7	41.5	6.0	4.5	13.0	41.5	61.6	60.0	22.0	39.9	96.0	27.9	14.2	58.6	58.6

Fig. 8.4a Example of filled in matrix and the corresponding reciprocal matrix

↑	1	2	3	4	5	6	7	8	9	10	11	12	13	14	15	16
1	0.07	0.07	0.10	0.17	0.05	0.03	0.10	0.09	0.10	0.05	0.11	0.09	0.09	0.07	0.10	0.10
2	0.07	0.07	0.10	0.17	0.05	0.03	0.10	0.09	0.10	0.05	0.11	0.09	0.09	0.07	0.10	0.10
3	0.02	0.02	0.02	0.04	0.03	0.01	0.02	0.04	0.04	0.01	0.03	0.06	0.01	0.02	0.04	0.04
4	0.07	0.07	0.10	0.17	0.22	0.20	0.18	0.15	0.15	0.41	0.19	0.09	0.21	0.30	0.15	0.15
5	0.31	0.31	0.18	0.17	0.22	0.20	0.18	0.15	0.12	0.19	0.19	0.09	0.21	0.30	0.15	0.15
6	0.19	0.19	0.14	0.06	0.09	0.08	0.06	0.07	0.07	0.05	0.07	0.08	0.09	0.03	0.07	0.07
7	0.02	0.02	0.02	0.02	0.03	0.03	0.02	0.04	0.04	0.01	0.03	0.06	0.01	0.02	0.04	0.04
8	0.01	0.01	0.01	0.02	0.02	0.02	0.01	0.02	0.02	0.01	0.01	0.04	0.01	0.01	0.02	0.02
9	0.01	0.01	0.01	0.02	0.03	0.02	0.01	0.02	0.02	0.01	0.01	0.04	0.01	0.01	0.02	0.02
10	0.07	0.07	0.10	0.02	0.05	0.08	0.10	0.09	0.10	0.05	0.07	0.08	0.09	0.03	0.07	0.07
11	0.02	0.02	0.02	0.02	0.03	0.03	0.02	0.04	0.04	0.02	0.03	0.06	0.01	0.02	0.04	0.04
12	0.01	0.01	0.00	0.02	0.02	0.01	0.00	0.00	0.00	0.01	0.00	0.01	0.01	0.01	0.01	0.01
13	0.03	0.03	0.06	0.03	0.04	0.03	0.06	0.07	0.07	0.02	0.07	0.06	0.04	0.03	0.07	0.07
14	0.07	0.07	0.10	0.04	0.05	0.20	0.10	0.09	0.10	0.12	0.11	0.08	0.09	0.07	0.07	0.07
15	0.01	0.01	0.01	0.02	0.02	0.02	0.01	0.02	0.02	0.01	0.01	0.03	0.01	0.02	0.02	0.02
16	0.01	0.01	0.01	0.02	0.02	0.02	0.01	0.02	0.02	0.01	0.01	0.03	0.01	0.02	0.02	0.02
sum	1.00	1.00	1.00	1.00	1.00	1.00	1.00	1.00	1.00	1.00	1.00	1.00	1.00	1.00	1.00	1.00

**Fig. 8.4b** Normalized reciprocal matrix corresponding to the example of filled matrix, continuation of Figure 8.4a.

With the principal eigenvalue of 17.9 from Equation (8.2) a consistency index of 0.12 results. This result has, however, not much meaning yet. The important measure is a ratio called *consistency ratio*, *CR*. It is given by **Saaty 1990**:

$$CR = \frac{CI}{RI} \leq 10\% \quad (8.5)$$

*RI* is called random consistency index and has the meaning of a consistency index

$$RI = (\lambda_{max,av} - n)/(n-1) .$$

$\lambda_{max,av}$  is the average of all principle eigenvalues obtained from evaluating very many matrices filled with random numbers. This means, if a matrix is filled for evaluation without giving any thought to, it will already have a certain consistency index  $CI > 0$ . Giving some thought to filling out the evaluation matrix should achieve a smaller *CI*. The consistency ratio, *CR* is hence the ratio of the *CI* of the evaluators matrix divided by the *CI* filled out randomly. If the consistency ratio, *CR* is sufficiently small (about 10 % or less) the evaluation is considered acceptable and the weights vector *w* can be trusted, otherwise consistency should be improved.

For  $n = 16$ , which is the size of the matrix in page 2 of the questionnaire, the random consistency index is  $RI = 1.5978$ . With consistency index *CI* of 0.12 (calculated from Figure 8.4) this results in this example to a  $CR = 7.5\%$  which is acceptable because it is below 10% (Equation 8.5).

Alonso 2006 presents an estimation method for  $\lambda_{max,av} = f(n)$  and hence  $RI = f(n)$  obtained from fitting a function to a very large number of principle eigenvectors from matrices with random numbers.

$$\begin{aligned}\lambda_{max,av} &= 2.7699 \cdot n - 4.3513 \\ RI &= (\lambda_{max,av} - n)/(n-1)\end{aligned}\tag{8.6}$$

$RI = f(n)$  is plotted in Figure 8.5.

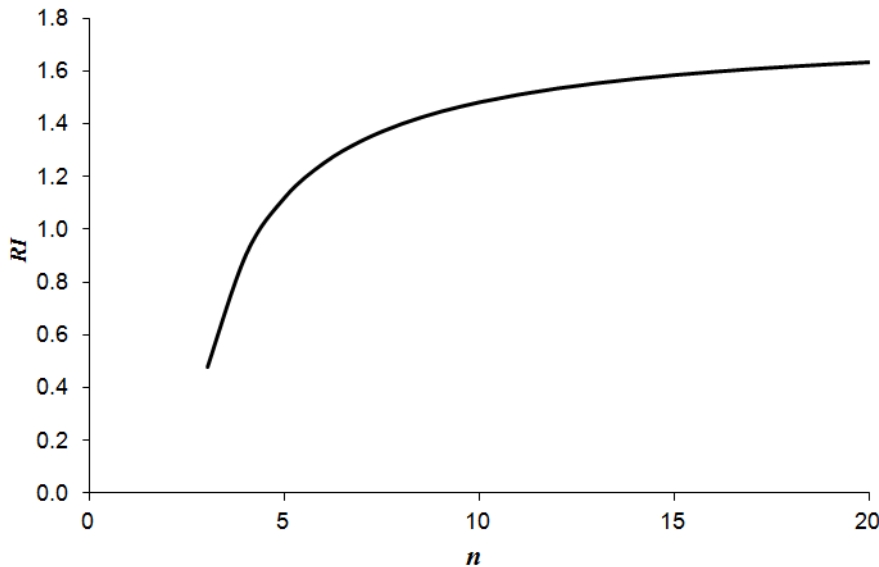
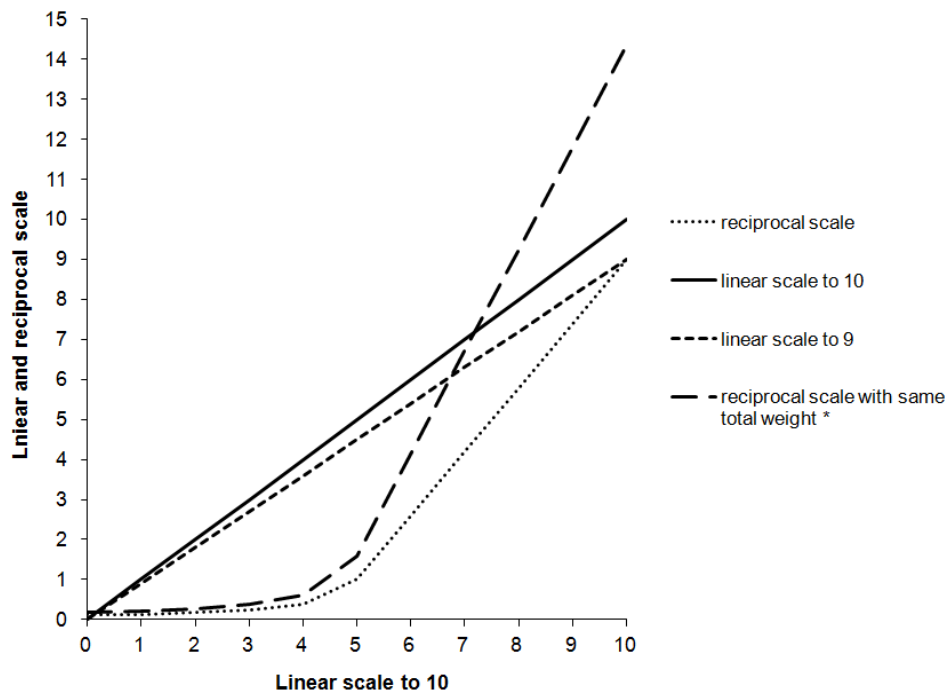

**Fig. 8.5** Random consistency index as a function of matrix size based on the estimation method for  $\lambda_{max,av} = f(n)$

### Comparison of Results

When comparing the weights vector  $w$  using the AHP matrix filled in by using the linear scale with the weights vector  $w$  using the same AHP matrix converted to the reciprocal scale, it is noticed that the resulting weights vector in the second case yields rather unrealistic values. In order to investigate this, Figure 8.6, based on Table 8.5, compares linear and reciprocal scales.

The horizontal axis in the plot is the linear scale to 10. The dotted line shows how points are attributed, when a reciprocal scale is used. The phenomenon becomes obvious when the “linear scale to 9” is compared with the “reciprocal scale to 9 with the same total weight as the linear scale to 9”. Few points are given to low (bad) evaluation results and more points are given to high (good) results. As a consequence the reciprocal scale tends to polarize evaluations too much which may not be what is intended. This is the reason why *all the comparative and final results were interpreted using the linear scale*. The reciprocal scale was only used for calculation of the consistency ratio,  $CR$  which only works on reciprocal matrices.



\*as the linear scale to 9

**Fig. 8.6** Comparison of linear and reciprocal scales

**Table 8.5** Linear and reciprocal scales

	Linear scale to 10	Reciprocal scale	Linear scale to 9	Reciprocal scale with the same total weight as the linear scale to 9
	0	0.111	0.0	0.177
	1	0.135	0.9	0.215
	2	0.172	1.8	0.275
	3	0.238	2.7	0.380
	4	0.385	3.6	0.613
	5	1.000	4.5	1.595
	6	2.600	5.4	4.146
	7	4.200	6.3	6.698
	8	5.800	7.2	9.249
	9	7.400	8.1	11.800
	10	9.000	9.0	14.352
Sum	55	31.041	49.5	49.500

Additional data examination was performed, namely a comparison of results between page 1 in questionnaire (Hierarchical Table) and page 2 in questionnaire (Analytic Hierarchy Process matrix). These assessments were performed via a correlation factor,  $R$  calculated based on standard deviation, as shown in Equation (8.7). The comparison measure was  $R^2$ , called *coefficient of determination* (in German: Bestimmtheitsmaß).  $R^2$  roughly indicates which percentage of the variation in the first variable can be explained with the variation in the second variable.



- Coefficient of determination from comparison of AHP-Linear with AHP-Reciprocal:  
 $R_3^2 = 0.880$

To summarize, the questionnaire assessment steps were:

- Calculation of resulting weights from the Hierarchical Table (page 1)
- Calculation of the normalized reciprocal matrix and the corresponding eigenvector of the AHP matrix
- Calculation of weights (scaled to 100%) from the AHP matrix in page 2 with linear evaluation scale
- Calculation of weights (scaled to 100%) from the AHP matrix in page 2 with reciprocal evaluation scale
- Calculation of the coefficient of determination for each comparative case (Hierarchical Table with AHP-Linear, Hierarchical Table with AHP-Reciprocal, AHP-Linear with AHP-Reciprocal)
- Calculation of the principal eigenvalue, consistency index, consistency ratio of the AHP matrix, consistency check

### 8.2.3 Results of Questionnaires Evaluation

#### Participants

22 persons from the following categories filled in the questionnaires:

- Experts
  - Engineer from Aircraft Manufacturer: 3
  - Airline Captain: 1
  - Aircraft Design Professor: 1
- Aircraft Design PhD Students: 12
- Aircraft Design Students: 5

Separate additional comments from expert discussions were very helpful. Results are presented in Table 8.7, 8.8 and 8.9 in anonymous form.

#### Hierarchical Table versus AHP Matrix

In general, the AHP matrices show poor consistencies. In all groups  $CR > 10\%$  and hence the results demand improvement. The standard deviation for the Added Values in Table 8.9 highlights that the AHP matrices do not show meaningful (interesting) results. All Added Values come out with similar importance. This does not match reality and it also does not help the Aircraft Design process. It can be concluded that the much simpler evaluation of the Hierarchical Table is more suitable than the AHP matrix, for which  $CR$  yields large inconsistencies even for expert weightings.



Table 8.7 summarizes important averages of key evaluation parameters. Students show the highest consistency ratio for the AHP matrix on page 2. Experts have better coefficient of determination when comparing the Hierarchical Table with AHP-Linear and with AHP-Reciprocal.

**Table 8.7** Averages of key evaluation parameters

Group	Parameter and average	Lowest value	Highest value	Comments
Experts	$CR = 38.5\%$	7.5 %	65.0 %	1 / 4 experts with acceptable $CR$
	$R_1^2 = 48.4\%$	17.5 %	83.6 %	comparison of Hierarchical Table with AHP-Linear
	$R_2^2 = 53.1\%$	26.2 %	78.0 %	comparison of Hierarchical Table with AHP-Reciprocal
	$R_3^2 = 69.3\%$	47.1 %	88.0 %	comparison of AHP-Linear with AHP-Reciprocal
Ph.D students	$CR = 19.1\%$	9.1 %	37.6 %	1 / 12 Ph.D students with acceptable $CR$
	$R_1^2 = 34.8\%$	16.8 %	48.7 %	comparison of Hierarchical Table with AHP-Linear
	$R_2^2 = 41.8\%$	15.9 %	52.3 %	comparison of Hierarchical Table with AHP-Reciprocal
	$R_3^2 = 88.9\%$	69.9 %	96.5 %	comparison of AHP-Linear with AHP-Reciprocal
Students	$CR = 12.7\%$	6.9 %	21.8 %	2 / 5 students with acceptable $CR$
	$R_1^2 = 14.9\%$	2.7 %	37.4 %	comparison of Hierarchical Table with AHP-Linear
	$R_2^2 = 22.7\%$	2.0 %	54.1 %	comparison of Hierarchical Table with AHP-Reciprocal
	$R_3^2 = 86.7\%$	74.9 %	95.7 %	comparison of AHP-Linear with AHP-Reciprocal
All	$CR = 23.5\%$	6.9 %	65.0 %	
	$R_1^2 = 32.7\%$	2.7 %	83.6 %	comparison of Hierarchical Table with AHP-Linear
	$R_2^2 = 39.2\%$	2.0 %	78.0 %	comparison of Hierarchical Table with AHP-Reciprocal
	$R_3^2 = 81.6\%$	47.1 %	96.5 %	comparison of AHP-Linear with AHP-Reciprocal

### Added Values versus DOC

The results from Table 8.8 show there is a good agreement that DOCs are more important than the Added Values. If the ratio is 3 to 1 or if it is 2 to 1, it can be debated. Experts also claim that the DOCs are everything and Added Values are nothing in practice. This extreme view is not helpful because it just states that the objective function for Aircraft Design should be DOC. In order to give a mixed DOC-Added-Value objective function some meaning, DOC have been selected to account (only) for 75%.

**Table 8.8** Group averages of Added Values main hierarchical breakdown

DOC respectively Added Value	From Hierarchical Table				Selected
	Experts	Ph.D stud.	Students	All	
1 DOC	73.8%	67.3%	64.0%	67.8%	75.0%
2 Added Values	26.3%	32.7%	36.0%	32.3%	25.0%
2.1 Performance	36.7%	48.0%	41.0%	44.4%	35.0%
2.2 Passenger Comfort	43.3%	34.9%	36.0%	36.5%	55.0%
2.3 Cargo / Baggage Handling	20.0%	17.1%	23.0%	19.1%	10.0%
2.1.1 Airport Performance	50.0%	55.0%	43.0%	51.1%	50.0%
2.2.2 Cruise Performance	50.0%	45.0%	57.0%	48.9%	50.0%
2.2.1 Concerning all passengers	66.7%	66.5%	71.0%	67.7%	80.0%
2.2.2 Concerning part of the passengers	33.3%	33.5%	29.0%	32.3%	20.0%
2.3.1 Concerning Cargo	70.0%	64.5%	42.0%	59.5%	80.0%
2.3.2 Concerning Cargo Working Conditions	30.0%	35.5%	58.0%	40.5%	20.0%

### **Added Values Weights from Main Hierarchical Breakdown**

Table 8.8 shows further that Performance (in addition to performance parameters influencing DOC directly) and Passenger Comfort are most important among Added Values. The expert view stresses the importance of passenger related Added Values. Revenue from passenger aircraft, however, comes from passengers and only to a small part from cargo. For this reason passenger related Added Values should be valued more than twice as cargo related Added Values.

On the next level of detail, Airport Performance (take-off and landing distance) are weighted against Cruise Performance (cruise speed, taken as a measure of convenience). On average, experts and the overall evaluation take these two as equal important. Note that take-off distance and landing distance are not two independent parameters. An aircraft that lands at an airport also has to take-off from that airport. A better and more general view would be this: There is only one distance to be considered: the longer of the take-off distance and the landing distance. In general this is the take-off distance, so only this should be evaluated, the shorter one being ignored (and be given 0 %).

Added Values from which all passengers benefit should clearly be given more importance compared to Added Values from which only part of the passengers benefit. A ratio 3 to 1 is seen here on average. Looking at further details hidden in these categories, a ratio 4 to 1 may seem even more appropriate and was selected (see the next paragraph, Selection of Final weights), because “2.2.1 Concerning all passengers” is further split into 7 Added Values, whereas “2.2.2 Concerning part of the passengers” is split only into 2 Added Values in the next level of the hierarchy. This fact may have been overlooked by some participants.

Added Values related to cargo handling can come from

- a) the general way cargo is handled (containerized versus bulk) and
- b) the details of cargo handling based on the aircraft parameters which are the accessibility of the cargo compartment (sill height) and the working conditions within the cargo compartment (cargo compartment height).

Experts clearly stress a), whereas students have opted for b) as being more important. It is important to understand that if cargo is containerized and the aircraft offers (semi-)automatic loading then acceptable cargo handling working conditions are automatically met. If all airlines want to work with containerized cargo in the first place is another (open) question.

Overall the Added Value receiving the highest weights are cruise speed, containerized cargo (yes / no) and take-off field length (see Table 8.9).

**Table 8.9** Group averages of Added Values (scaled to 100 %) from Hierarchical Table (page 1) and from AHP linear (page 2)

Added Value	From Hierarchical Table				From AHP linear			
	Experts	Ph.D stud.	Students	All	Experts	Ph.D stud.	Students	All
Landing field length	3.8 %	9.0 %	6.1 %	7.2 %	2.7 %	7.2 %	6.7 %	6.3 %
Take-off field length	8.6 %	11.1 %	6.1 %	9.4 %	9.6 %	8.4 %	6.8 %	8.2 %
Relative landing weight	2.8 %	4.8 %	4.4 %	4.3 %	2.3 %	6.3 %	7.6 %	6.0 %
Cruise speed	15.8 %	23.1 %	24.4 %	22.0 %	10.1 %	8.9 %	7.6 %	8.8 %
Seat pitch	6.2 %	4.4 %	5.5 %	5.0 %	5.2 %	7.2 %	7.1 %	6.9 %
Seat width	6.7 %	4.7 %	3.1 %	4.7 %	8.3 %	7.6 %	6.3 %	7.4 %
Armrest width	3.2 %	1.8 %	2.7 %	2.3 %	6.0 %	3.9 %	5.0 %	4.5 %
Aisle width	5.1 %	2.4 %	3.0 %	3.1 %	6.3 %	5.6 %	5.6 %	5.7 %
Aisle height	2.2 %	2.4 %	3.4 %	2.6 %	3.4 %	5.2 %	5.8 %	5.1 %
Overhead bin volume per pax	6.9 %	3.8 %	3.9 %	4.5 %	8.1 %	7.1 %	5.7 %	6.9 %
Aircraft gust sensitivity	3.0 %	2.9 %	3.8 %	3.2 %	5.0 %	6.6 %	6.3 %	6.3 %
Sidewall clearance	6.8 %	4.6 %	4.5 %	5.0 %	4.6 %	4.2 %	4.2 %	4.3 %
Number of "excuse-me" seats	9.8 %	7.7 %	6.0 %	7.7 %	6.9 %	55.3 %	5.0 %	5.5 %
Containerized cargo (yes/no)	13.1 %	10.5 %	9.9 %	10.8 %	8.4 %	6.0 %	7.3 %	6.8 %
Accessibility factor	3.1 %	3.7 %	7.5 %	4.5 %	6.6 %	5.4 %	6.7 %	5.9 %
Cargo compartment height	2.6 %	3.0 %	5.6 %	3.6 %	6.6 %	5.0 %	6.3 %	5.6 %
	standard deviation			4.8 %	standard deviation			1.2 %

## 8.2.4 Selection of Final Weights

Results of the questionnaire evaluation show a diverse picture. The final weights for the Added Values should not be a “democratic average” but rather the best selected from overall knowledge gained from much insight into the topic and expert views challenged by views of students from the field. For these reasons it was decided to determine the final weights from the *best answer* (i.e. best consistency and high coefficients of determination) *corrected by technical insight, expert views and the average of all answers*. In its detail this method is not an algebraic one but rather a subjective trade-off. The resulting final weights are given in Table 8.10 and Table 8.11. The final weights in Table 8.10 may be compared with values in Table 8.8 and Table 8.9.

DOCs were selected to have a weight of 75 % – enough to account strongly for economic importance, yet leaving room for additional revenue generated by Added Values (namely 25 %). Passenger comfort was considered more important than performance: 55 % versus 35 %, while cargo working conditions received only 10 %. Cruise and airport performance were considered equally important.

Regarding comfort, the standards concerning all passengers received a higher weight (namely 80 %) than the standards concerning only part of the passengers (20 %). Among the parameters concerning the comfort of all passengers, seat pitch was seen to be the most important one, followed by seat width and overhead stowage volume. Even though seat pitch is defined by the airlines, the idea is here to optimally set important parameters for airlines (such as seat pitch), already during preliminary design. Seat pitch will define at this stage the cabin length and thus will have a major influence on the entire design. The next important parameters are armrest width, followed by gust sensitivity and aisle width and height. Aisle

width is more critical for single aisle aircraft because a single aisle offers fewer possibilities for a passenger to bypass a trolley in the aisle during catering service.

**Table 8.10** Attributed weights to the Added Values

Economics			Equiv. ton-mile costs									Absolute weights	Added Values scaled to
75 %			100 %									75.00%	100 %
Added Values	Performance	35 %	Concerning all passengers	80 %	Airport performance	50 %	Landing field length	0 %	0.00%	0.00%			
					Take-off field length	80 %	3.50%	14.00%					
					Relative landing weight ( $m_{ML}/m_{MTO}$ )	20 %	0.88%	3.50%					
					Cruise performance	50 %	Cruise speed	100 %	4.38%	17.50%			
					Concerning part of the passengers	20 %	Sidewall clearance	10 %	0.28%	1.10%			
	Passenger Comfort	55 %	Concerning all passengers	80 %	Seat pitch	30 %	3.30%	13.20%					
					Seat width	20 %	2.20%	8.80%					
					Armrest width	10 %	1.10%	4.40%					
					Aisle width	5 %	0.55%	2.20%					
					Aisle height	5 %	0.55%	2.20%					
	Cargo Handling	10 %	Concerning cargo working conditions	80 %	Overhead bin volume per pax	20 %	2.20%	8.80%					
					Aircraft gust sensibility	10 %	1.10%	4.40%					
					Concerning cargo	80 %	2.00%	8.00%					
						Number of "excuse-me" seats	90 %	2.48%	9.90%				
						Containerized cargo (yes/no)	100 %	2.00%	8.00%				
						Accessibility factor	50 %	0.25%	1.00%				
						Cargo compartment height	50 %	0.25%	1.00%				
<b>Check:</b>											100.00%	100.00%	

It can be concluded that an efficient design is not a design that only reduces costs but also a design able to anticipate the later scenarios that an airline could consider necessary to implement. Without this design flexibility, the airline may decide not to buy the aircraft. Concerning the optimal comfort standards, that an aircraft manufacturer should consider, an interesting expert comment is: if too much cabin comfort is given (seat width and aisle width), airlines may end up squeezing more seats in a row than originally intended for the aircraft. The result of this is a cabin with no comfort at all. The BAe 146 is such an aircraft that was designed as a five abreast aircraft and was equipped in some cases also with 6 seats abreast.

Looking finally at the resulting absolute weights of the Added Values, cruise speed and take-off field length have the highest percentages of 4.38 % and 3.50 %, respectively. They are followed by seat pitch (3.30 %), number of “excuse-me” seats (2.48 %), seat width (2.20 %) and overhead stowage volume (2.20 %). These final weights make sense and stand a common sense check: It is first of all important to get us inexpensive from A to B within short time. During the flight we want to sit with some comfort in our seat, want to get out of our seat without too much hazel when necessary and we like to have much of our baggage with us in the cabin.

Besides absolute weights, Table 8.11 shows (for a medium range aircraft) the low and high limits, the resulting points and scores for a set of parameters, that in OPerA may result either from an optimization run, or are manually calculated.

**Table 8.11** Attributed weights to the Added Value and score calculation for the composed objective function

	Absolute weights	Attribute low limit	Attribute high limit	Values of optimization	Point for optimization	Score for optimization	Comments
Economics (DOC)	75.00%	1.1893108	1.3735239	1.284	4.9	3.664	10 points for min
Landing field length	0.00%	1370	2000	1447.8	8.8	0.000	10 points for min
Take-off field length	3.50%	1670	2700	1767.83	9.1	0.317	10 points for min
Relative landing weight ( $m_{ML}/m_{MTO}$ )	0.88%	0.8	1	0.878	3.9	0.034	10 points for max
Cruise speed	4.38%	224.25	237.3279	224.25	0.0	0.000	10 points for max
Seat pitch	3.30%	28	32	29	2.5	0.082	10 points for max
Seat width	2.20%	0.44	0.53	0.508	7.4	0.162	10 points for max
Armrest width	1.10%	0.04	0.06	0.051	5.4	0.059	10 points for max
Aisle width	0.55%	0.2	0.61	0.508	7.5	0.041	10 points for max
Aisle height	0.55%	1.75	2.1	2.264	10.0	0.055	10 points for max
Overhead bin volume per pax	2.20%	0.03	0.1	0.044	2.1	0.045	10 points for max
Aircraft gust sensibility	1.10%	0.1	1	0.34	7.4	0.081	10 points for min
Sidewall clearance	0.28%	0.007	0.02	0.015	6.2	0.017	10 points for max
Number of "excuse-me" seats	2.48%	0	3	0	10.0	0.248	10 points for min
Containerized cargo (yes/no)	2.00%			Yes	10.0	0.200	10 points for yes
Accessibility factor	0.25%	1	1.1	1.09	1.2	0.003	10 points for min
Cargo compartment height	0.25%	0.7	1.8	1.22	4.7	0.012	10 points for max
	100%						
						5.02046764	=maximum

## 8.2.5 Building the Objective Function

The score of each Added Value is calculated as a product between the weight and the resulting point, as explained in the first paragraph. The objective function is given by the sum of scores, which can reach a maximum of 10. Hence *the objective is to maximize (up to 10) the composed DOC + AV function (AV = Added Value)*.

## 8.2.6 Summary

This section aimed to deliver the general evaluation of the questionnaire filled in by a group of participants. More specific, the aim was to determine weights among Added Values. Added Value boundaries were discussed, the way points are attributed to aircraft parameters resulting from optimization runs is explained, and questionnaire evaluation methods were presented.

For the AHP matrix a consistency check was performed for every participant. Its calculation is based on the principal eigenvalue of the matrix for which a simple approximate evaluation method based on the normalized reciprocal matrix is available. Comparisons were performed via the coefficient of determination,  $R^2$ , between weights from the Hierarchical Table (page 1 of the questionnaire) and the AHP matrix (page 2 of the questionnaire) from a linear or a reciprocal evaluation scale. The reciprocal scale yielded unrealistic results. The only purpose

of the matrix based on the reciprocal scale is hence the consistency check with the consistency ratio (which is not defined for a matrix based on a linear scale).

The Hierarchical Table was considered more suitable for defining the final weights. Final weights were determined from the best answer (i.e. best consistency and high coefficients of determination) corrected by technical insight, expert views and the average of all answers. Accordingly, Added Values have an importance of 25 % (75 % for DOCs). Resulting absolute weights of the Added Values, cruise speed and take-off field length have the highest percentages of 4.38 % and 3.50 %, respectively. They are followed by seat pitch (3.30 %), number of “excuse-me” seats (2.48 %), seat width (2.20 %) and overhead stowage volume (2.20 %).

## **8.2.7 Conclusions and Lessons Learnt**

### **Conclusions regarding Questionnaires Evaluation**

The AHP matrix was rather difficult for the participants to fill in, due to its large size. It is interesting that a method exists that is checking the consistency of the information filled in. Satisfactory consistencies could have been obtained easier if the participants filling in the AHP matrix would have had already knowledge of the weights resulting from the Hierarchical Table. Unfortunately the questionnaire did not provide this information because an independent start for the AHP matrix was intended. Showing the final weights resulting from the Hierarchical Table during the participant’s evaluation could also have had a beneficial influence on the Hierarchical Table itself.

Transforming the linear scale, that the participants used to fill in the matrix, into a reciprocal one, results in a quite polarized weights assignment. Also for simplicity reasons, a linear scale is more suitable and better understandable.

### **Conclusions regarding Added Values**

It is not necessary to include landing field length as Added Value (take-off field length would have been enough). The selection of the rest of the Added Values seems to be a good choice. Arguments for this statement are the expert comments and also the results of the optimization runs (with the objective  $DOC + AV = \text{maximum}$ ) performed with OPerA. To be reminded that the fundamental purpose was to optimize the preliminary design of a *new* aircraft.

### **Lessons Learnt**

It was found that the Hierarchical Table is better suited than filling in a large matrix. For results obtained from the Hierarchical Table it would have been even better if we would have displayed the resulting weightings already in the questionnaire. In this way the participants would have had a better overview of the results of their selections. Instead of filling in a large

matrix, splitting the Added Values into smaller selected matrices would have eased this task. For example only (all the) 9 cabin parameters or only the 7 “concerning all passengers” parameters could have been represented in a matrix (without the other parameters to be included in the AHP). This would have resulted in a better manageable number of evaluations  $m = (n^2 - n) / 2$  (36, respectively 21 compared to 120 in the questionnaire).

## 9 Optimization Results

In order to test and prove the reliability of *OPerA* a number of study cases, starting from the reference aircraft A320-200, were performed:

- A. Standard configuration
- B. Configuration with braced wings
- C. Configuration with natural laminar flow on wings
- D. Configuration with braced wings and natural laminar flow on wings

The strategy used for optimization was:

- 1.) *design exploration*: understanding the effects of varying single aircraft and cabin parameters on the design; understanding the effect of varying requirements; understanding the relationship between parameters;
- 2.) *optimization*: understanding the effect of varying parameter combinations and requirements on the design; understanding the influence of different objective functions on the design; design optimization.
- 3.) *technology integration*: understanding the effect of high bypass ratio engines, winglets and span limitation, braced wing and natural laminar flow on the design; design optimization.

### 9.1 Parameters and Parameter Combinations

Different parameter combinations were tested. First, for understanding the behavior of the parameters and their relations, and second, for understanding if the models included in the tool follow expected, logical variations. The entire design of the tool was in fact a highly iterative one, and a lot of knowledge was gained during the evaluations. The pedagogical side of the tool, besides the practical one, has proved its efficiency. A lot of plots of practically any output or input could be shown here. The most important test cases are however selected and presented in the following sections. Table 9.1 lists the aircraft and cabin parameters varied in different combinations.

Table 9.2 lists the boundaries of each parameter that define the design space. Optimization with stochastic algorithms proved that these boundaries play an important role in solution accuracy: the larger the design space, the higher the risk of not finding the (probably) best global optimum (Finding the absolute global optimum is not guaranteed by stochastic algorithms; yet a smaller design space increases the chances of an absolute convergence). Optimus® is less sensitive to the boundaries than the VBA algorithm implemented in *OPerA*.



**Table 9.1** List of aircraft and cabin optimization variables and their values for the reference aircraft

Parameter		Value for A320-200 aircraft
Landing field length [m]	$S_{LFL}$	1447.80
Take-off field length [m]	$S_{TOFL}$	1767.83
Max. lift coefficient, landing for unswept wing	$C_{L,max,L,unswept}$	3.39
Max. lift coefficient, take-off for unswept wing	$C_{L,max,TO,unswept}$	2.95
Mass ratio, max landing to max take-off	$m_{ML} / m_{MTO}$	0.88
Aspect ratio	$A$	9.50
Number of engines	$n_E$	2.00
Number of passengers	$n_{PAX}$	180
Number of seats abreast	$n_{SA}$	6
Wing sweep at 25% chord [°]	$\varphi_{25}$	25
Taper ratio	$\lambda$	0.24
Position of the vertical tail in case of cruciform configuration	$z_H/b_V$	0.56
Minimum distance from engine to wing over nacelle diameter	$z_{P,min}/D_N$	0.15
By-Pass ratio	$BPR$	6
Mach number, cruise	$M_{CR}$	0.76
Seat pitch [m]	$SP$	29
Aisle width [m]	$w_{aisle}$	20
Seat width [m]	$w_{seat}$	20
Armrest width [m]	$w_{armrest}$	2
Sidewall Clearance (at armrest) [m]	$s_{clearance}$	0.015

**Table 9.2** Low and high boundaries set for each variable in the optimization process

Parameter		Low limit	High limit
Landing field length [m]	$S_{LFL}$	1000	2700
Take-off field length [m]	$S_{TOFL}$	1000	2700
Max. lift coefficient, landing for unswept wing	$C_{L,max,L,unswept}$	2	3.4
Max. lift coefficient, take-off for unswept wing	$C_{L,max,TO,unswept}$	2	3.4
Mass ratio, max landing to max take-off	$m_{ML} / m_{MTO}$	0.83	1
Aspect ratio	$A$	4	40
Number of engines	$n_E$	1	4
Number of passengers	$n_{PAX}$	100	250
Number of seats abreast	$n_{SA}$	4	8
Wing sweep at 25% chord [°]	$\varphi_{25}$	0	35
Taper ratio	$\lambda$	0.15	0.5
Position of the vertical tail in case of cruciform configuration	$z_H/b_V$	0.1	0.9
Minimum distance from engine to wing over nacelle diameter	$z_{P,min}/D_N$	0.1	0.3
By-Pass ratio	$BPR$	4	30
Mach number, cruise	$M_{CR}$	0.55	0.85
Seat pitch [m]	$SP$	0.711	0.813
Aisle width [m]	$w_{aisle}$	0.508	0.610
Seat width [m]	$w_{seat}$	0.437	0.533
Armrest width [m]	$w_{armrest}$	0.040	0.060
Sidewall Clearance (at armrest) [m]	$s_{clearance}$	0.007	0.020

A number of 24 parameter combinations were tested, for each objective function. These combinations are listed in Table 9.3a, and 9.3b. The strategy was the following:

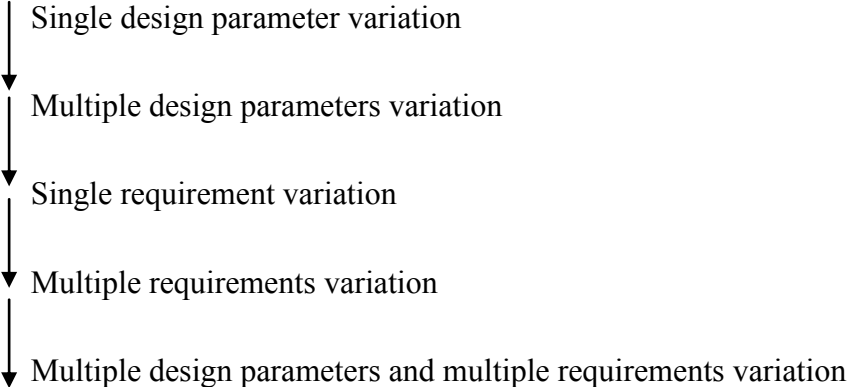

Single parameter variations can be visualized in two-dimensional scatters. In Optimus® three-dimensional representations (through 3D scatters) and four-dimensional representations (through bubble plots) are possible. Figures 9.1 to 9.4 show examples of how design space can be explored. The objectives are minimum Direct Operating Costs and Maximum Take-Off Mass.

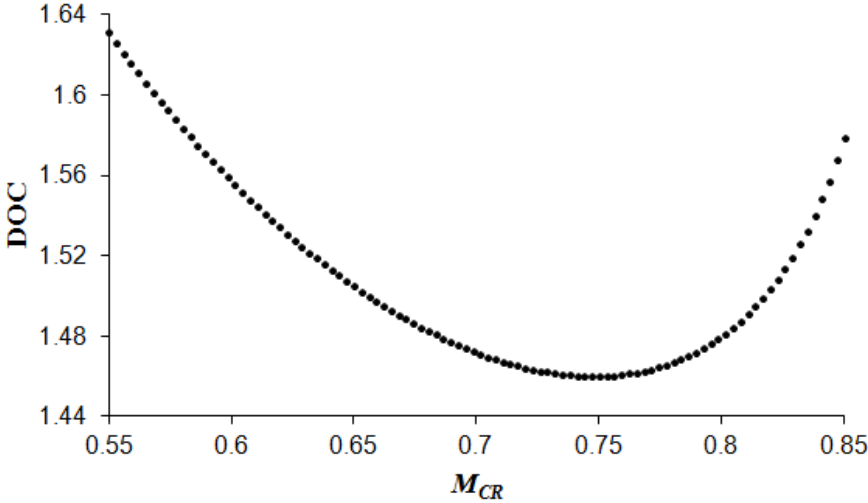

**Fig. 9.1** Representation of experiment A15-DOC, where cruise Mach number is varied

From the DOC perspective, it is always better to fly faster; this is how aircraft become more productive. However, in the given parameter combination (the rest of the parameters are kept as for the original A320-200 reference aircraft), there is an optimal Mach number (Figure 9.1).

**Table 9.3a** Optimization cases for standard configuration starting from A320-200 baseline. XXX in Case ID stands for: DOC – Direct Operating Costs, MTO – maximum take-off mass, MF – fuel mass, DOC+AV – Direct Operating Costs and Added Values

Strategy step	Parameter combination <sup>1</sup>	Case ID	Number of varied parameters
Single design parameter variation	$m_{ML} / m_{MTO}$	A1-XXX	1
	$A$	A2-XXX	1
	$C_{L,max,L,unswept}$ $C_{L,max,TO,unswept}$	A3-XXX	2
	$\varphi_{25}$	A4-XXX	1
	$\lambda$	A5-XXX	1
	$BPR$	A6-XXX	1
	$n_{SA}$	A7-XXX	1
Multiple design parameter variation	$\varphi_{25}$ $\lambda$	A8-XXX	2
	$m_{ML} / m_{MTO}$ $A$ $C_{L,max,L,unswept}$ $C_{L,max,TO,unswept}$	A9-XXX	4
	$m_{ML} / m_{MTO}$ $A$ $C_{L,max,L,unswept}$ $C_{L,max,TO,unswept}$ $\varphi_{25}$ $\lambda$	A10-XXX	6
	$m_{ML} / m_{MTO}$ $A$ $C_{L,max,L,unswept}$ $C_{L,max,TO,unswept}$ $\varphi_{25}$ $\lambda$ $BPR$ $z_{P,min}/D_N$	A11a-XXX	8
	$m_{ML} / m_{MTO}$ $A$ $C_{L,max,L,unswept}$ $C_{L,max,TO,unswept}$ $\varphi_{25}$ $\lambda$ $BPR$ $z_{P,min}/D_N$ $SP$ $W_{aisle}$ $W_{seat}$ $W_{armrest}$ $S_{clearance}$ $n_{SA}$	A12-XXX	14
Single requirement variation	$A$ with span limitation at 52 m	A13-XXX	1
	$S_{LFL}$ $S_{TOFL}$	A14-XXX	2
	$M_{CR}$	A15-XXX	1
Multiple requirements variation	$A$ with span limitation at 52 m $S_{LFL}$ $S_{TOFL}$	A16-XXX	3
	$S_{LFL}$ $S_{TOFL}$ $M_{CR}$	A17-XXX	3
	$A$ with span limitation at 52 m $S_{LFL}$ $S_{TOFL}$ $M_{CR}$	A18-XXX	4

<sup>1</sup> Remarks: lift coefficients and distances for landing and take-off should only be varied *together*.

**Table 9.3b** Optimization cases for standard configuration starting from A320-200 baseline (continuation)

Multiple design parameters and multiple requirements variation	$m_{ML} / m_{MTO}$ <i>A with span limitation at 52 m</i> $C_{L,max,L,unswept}$ $C_{L,max,TO,unswept}$ $\phi_{25}$ $\lambda$ <i>BPR</i> $z_{P,min}/D_N$	A11b-XXX	8
	$m_{ML} / m_{MTO}$ <i>A</i> $C_{L,max,L,unswept}$ $C_{L,max,TO,unswept}$ $\phi_{25}$ $\lambda$ <i>BPR</i> $z_{P,min}/D_N$ $S_{LFL}$ $S_{TOFL}$ $M_{CR}$	A19a-XXX	11
	$m_{ML} / m_{MTO}$ <i>A with span limitation at 52 m</i> $C_{L,max,L,unswept}$ $C_{L,max,TO,unswept}$ $\phi_{25}$ $\lambda$ <i>BPR</i> $z_{P,min}/D_N$ $S_{LFL}$ $S_{TOFL}$ $M_{CR}$	A19b-XXX	11
	$m_{ML} / m_{MTO}$ <i>A</i> $C_{L,max,L,unswept}$ $C_{L,max,TO,unswept}$ $\phi_{25}$ $\lambda$ <i>BPR</i> $z_{P,min}/D_N$ $SP$ $W_{aisle}$ $W_{seat}$ $W_{armrest}$ $S_{clearance}$ $n_{SA}$ $S_{LFL}$ $S_{TOFL}$ $M_{CR}$	A20a-XXX	17
	$m_{ML} / m_{MTO}$ <i>A with span limitation at 52 m</i> $C_{L,max,L,unswept}$ $C_{L,max,TO,unswept}$ $\phi_{25}$ $\lambda$ <i>BPR</i> $z_{P,min}/D_N$ $SP$ $W_{aisle}$ $W_{seat}$ $W_{armrest}$ $S_{clearance}$ $n_{SA}$ $S_{LFL}$ $S_{TOFL}$ $M_{CR}$	A20b-XXX	17

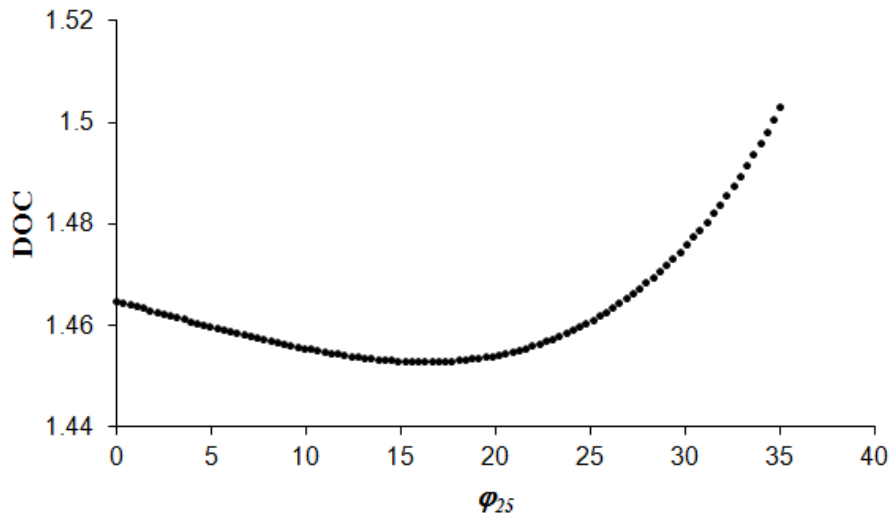

**Fig. 9.2** Representation of experiment A4-DOC, where sweep angle is varied

An optimal sweep, for the same parameter combination, is given in Figure 9.2.

With respect to lift coefficients, they always go towards maximum values (with  $C_{LmaxTO}$  smaller than  $C_{LmaxL}$ ). Their variation is given in Figure 9.3.

The bubble plot in Figure 9.4 summarizes the variation of 3 parameters. Two are given by the axes (landing and take-off field lengths), one is represented by the size of the bubbles (cruise Mach number), and the fourth, which is the output ( $m_{MTO}$ ), is given by the color of the bubbles. An advantage of this type of plot is that it allows visualization of both design space and evolution towards the optimum.

The next sections (9.2 to 9.6) present selected optimization results for all objective functions. Chosen for illustration was the case *20b*, which allows the highest design freedom, thus can provide the highest design improvements. Additionally, the case *11a* is shown for objective minimum DOC, in order to see what improvements can be achieved by optimizing strictly the A320-200 aircraft, without varying requirements or cabin parameters. Expected is to achieve the improvements of A320-NEO (since it is considered that NEO is the most that A320-200 can currently reach in efficiency (Press 2011), or even higher improvements, because, compared to NEO, where a new engine is added to the same wing, in case *11a*, wing parameters are also set free.

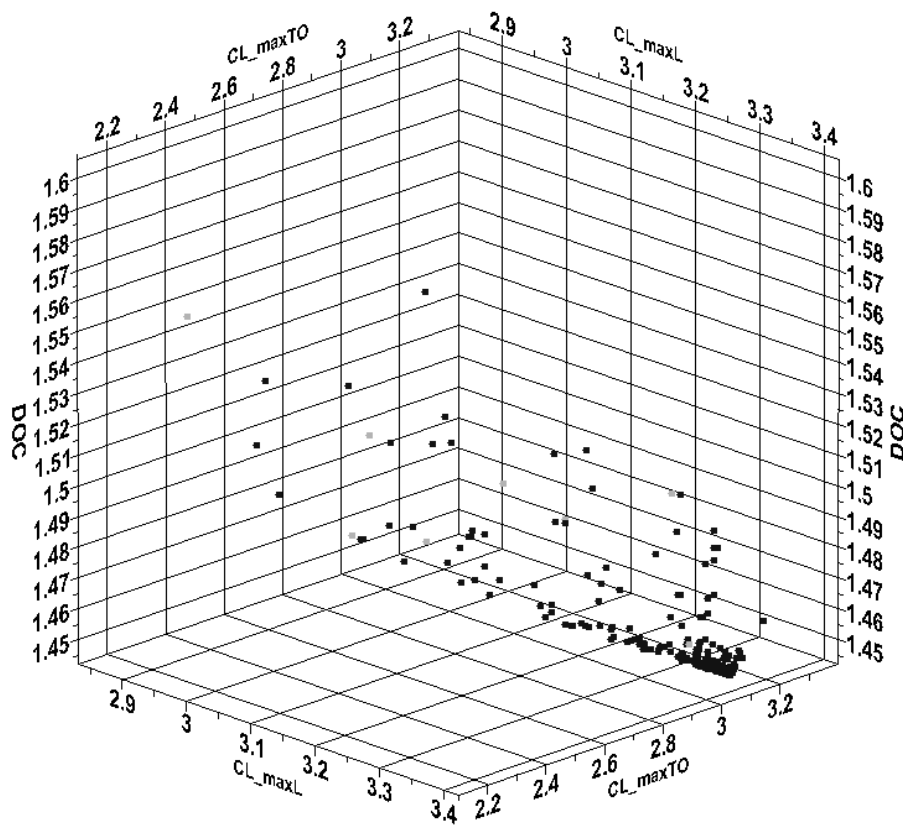

**Fig. 9.3** Representation of experiment A3-DOC, where the two lift coefficients for landing and take-off configuration (for unswept wing) are varied

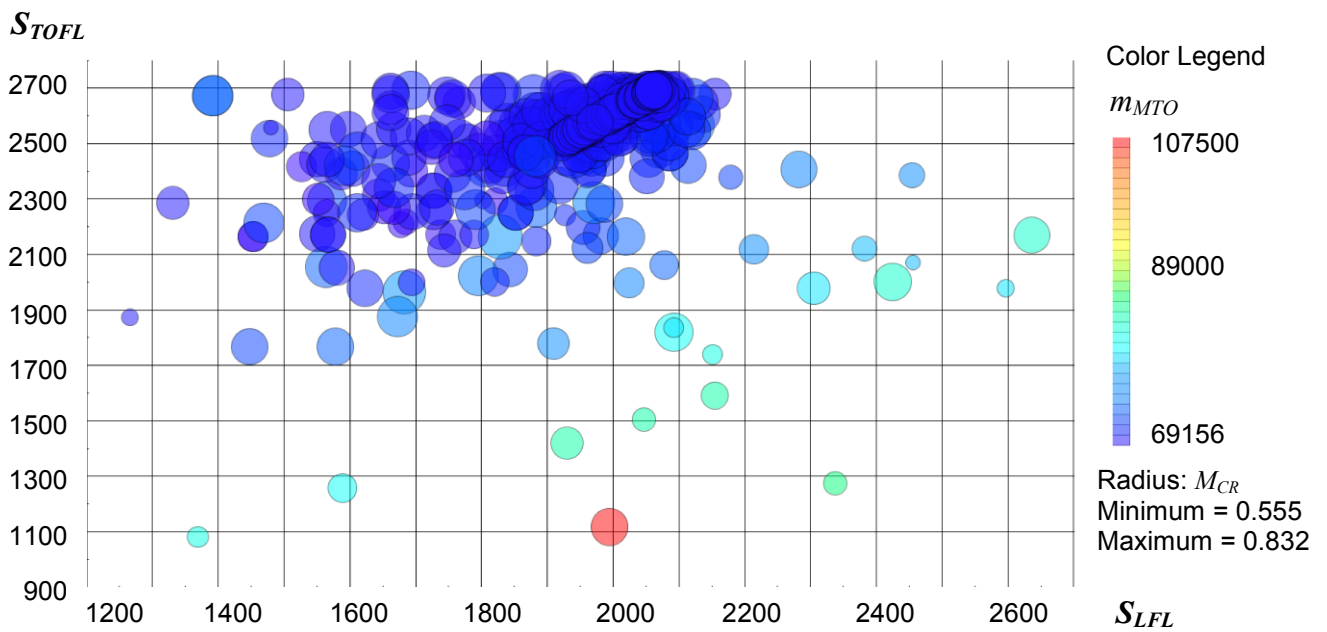

**Fig. 9.4** Representation of experiment A17- $m_{MTO}$ , where take-off and landing as well as cruise requirements are varied

## 9.2 Optimization for Minimum DOC

### 9.2.1 Case A: Standard Configuration

When varying only design parameters, for the same requirements and cabin parameters, as well as the same airport category as the original A320-200 aircraft (case 11a), with the objective minimum DOC, the improvements obtained with OPerA are: 3.4 % reduction in maximum take-off mass, 14.54 % reduction in fuel mass, 3.16 % reduction in DOC and an increase in the DOC + Added Values score from 4.5 to 6.1. These reductions are obtained for the parameter values listed in Table 9.4. The resulting matching chart is shown in Figure 9.5.

**Table 9.4** Results of experiment A11a-DOC

Parameter	Optimized value
$m_{ML} / m_{MTO}$	0.89
$A$	12.27
$C_{L,max,L,unswept}$	3.39
$C_{L,max,TO,unswept}$	3.25
$\Phi_{i_{25}}$	16.81°
$\lambda$	0.15
$BPR$	8.59
$h_{P,min}/D_N$	0.10

Aspect ratio is as high as the 36 m span limitation allows it; winglets with the height of 1.74 m are automatically added to improve the design (resulting geometrical aspect ratio is 11.36). Speed is slightly higher, for the same Mach number, due to a slightly lower altitude. Sweep and taper ratio are smaller, which allows higher (swept) lift coefficients. Landing mass ratio is also smaller. Resulting by-pass ratio is about 9.

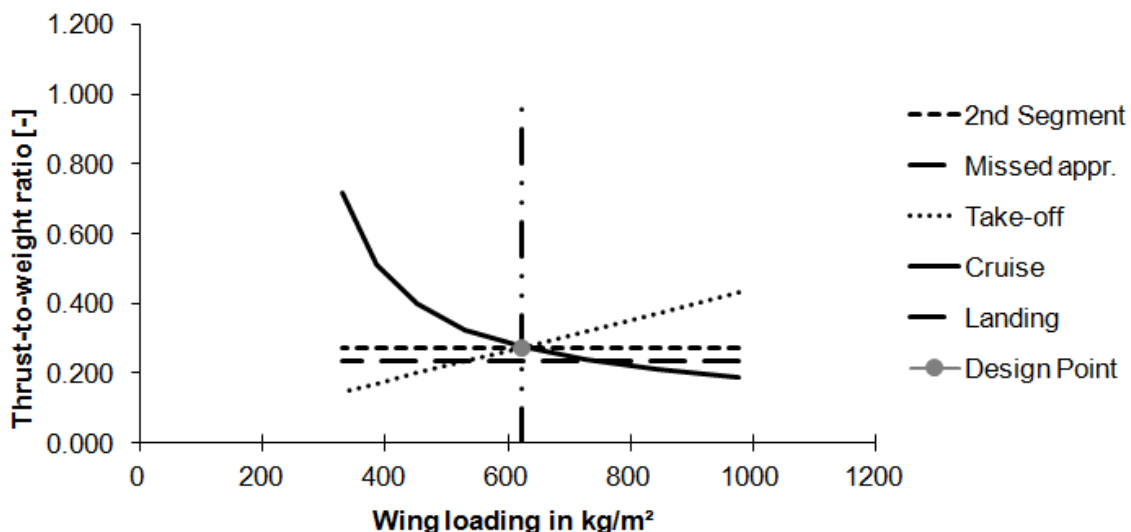

**Fig. 9.5** The resulting matching chart for the case A11a-DOC

When setting all parameters free, as in experiments of the type 19b and 20b the resulting DOC-optimized design has better aerodynamics (higher glide ratio) and better engine (smaller

SFC) than the original A320 aircraft. Setting requirements free is beneficial for the design. Landing and take-off field increase, hence relieving thrust and lift requirements. The cruise Mach number is slightly smaller, as well as sweep. Due to the fact that an increase in geometrical span was allowed, the design took advantage of this freedom and aspect ratio increased accordingly. Airbus designed the A320-200 aircraft for the 36 m span limitation category. The improvement in DOC when allowing a 52 m limitation is 7.0 % when varying all aircraft parameters (experiments from series 19b), and 11.4 % when optimizing aircraft parameters together with cabin parameters (experiments from series 20b). As a secondary effect of DOC optimization, fuel is improved by 23.5 % in case 19b and 29.5 % in case 20b. If in the future the fuel will become a more important driver in Aircraft Design and Optimization, then it is likely that aircraft manufacturers will have to move aircraft to the next airport category. To benefit from span increase and yet remain in the same airport category, some solutions are possible:

- Folding wings up: this may be a solution only at the cost of additional mass due to actuators and hinges; actuators would be required to ensure aircraft independency from ground assistance, hence avoiding delays in turnaround times.
- Rotating main landing gear: that allows the aircraft to move with an angle of 45° sideways into the parking position and given box. The wing can now use the diagonal of the box of given length,  $l$  and given width,  $w$ . The maximum wingspan in the diagonal is now  $b_{w,diag} = (l^2 + w^2)^{1/2}$ .
- Discussing (in particular) with airports possibilities to allow at least a few meters more for the span limitation without changing the airport category. This would be an alternative to the more complicated first two solutions.

Nevertheless, the tendency towards more openness in changing established limitations should increase and more attention should be given to studies on the effect of span increase on airport infrastructure (few airports are capable of accepting higher span aircraft and this represents the danger for the economic efficiency of the design; as an advantage, for a middle range aircraft designed with a higher span, no extra airport fees would be applied, as currently airports charge for maximum take-off mass).

More openness should be shown also regarding the rest of the requirements, such as lower speeds, which, as mentioned before, allow a better fuel consumption and smaller engines.

Mass reduction when varying only aircraft parameters and requirements (experiments from series 19b) is 10.3 %. The composed DOC and Added Values (AV) function showed an increase in score from 4.5 to 7.9 (corresponding to 34.4 %). When adding cabin parameters (experiments from series 20b), these percentages become: 16.2 % reduction in take-off mass, and an increase from 4.5 to 8.1 in DOC +AV.

Table 9.5 shows results from experiment 20b discussed above. Experiments from series 20b allow the highest design freedom compared to the baseline aircraft: both aircraft and cabin



parameters are set free and span is allowed to increase up to the limit of the next airport category, respectively 52 m.

**Table 9.5** Results of experiment A20b-DOC

Varied parameters	Domain of variation		Optimal parameter combination	Main outputs and their relative improvement compared to A320-200			
	Low limit	High limit		$m_{MTO}$ [kg] %	$m_F$ [kg] %	DOC [US\$/NM/t] %	DOC+AV [-] %
$m_{ML} / m_{MTO}$	0.83	1	0.897				
$C_{L,max,L,unswept}$	2	3.4	3.37				
$C_{L,max,TO,unswept}$	2	3.4	3.96				
$\varphi_{25}$ [°]	0	35	8.6				
$\lambda$	0.15	0.5	0.16				
$BPR$	5	30	9.9				
$z_{P,min}/D_N$	0.1	0.3	0.13				
$SP$	0.711	0.813	0.712	61620.2	9158.7	1.29	8.14
$w_{aisle}$	0.200	0.610	0.209				
$w_{seat}$	0.437	0.533	0.437	- 16.2 %	- 29.6 %	- 11.4 %	+ 36.25 %
$w_{armrest}$	0.040	0.060	0.041				
$s_{clearance}$	0.007	0.020	0.012				
$n_{SA}$	4	8	6				
$A$ - span limit 52 m	6	35	15				
$s_{LFL}$ [m]	1000	2700	1738				
$s_{TOFL}$ [m]	1000	2700	2676				
$M_{CR}$	0.55	0.85	0.70				

### 9.2.2 Case B: Configuration with Braced Wings

The braced wing configuration was commented on in Section 2.2, where theoretical advantages were indicated, based on own considerations and other research. The assumptions that braced wings consistently reduce mass and allow aerodynamical improvements, are proven also by the results in Table 9.6. Braced wings practically quantify improvements obtained from an optimized standard configuration. The objective is here DOC, so a maximum take-off mass reduction will be reached when optimizing for minimum mass.

The optimized standard version already requires a rather reduced sweep (due to a slightly reduced speed and due to the fact that this is beneficial also for the (swept) lift coefficients). A braced wing configuration allows even greater sweep reduction, at about the same speed. Natural laminar flow is applicable in both cases. Aspect ratio increase is also possible, compared to the standard optimized version. This allows a maximum glide ratio of 21.7. Cabin parameters remain in the area of the lower boundaries. The optimal fuselage

slenderness results to be 10.7. Improvements of meaningful parameters, including in objective DOC are given in the table below.

Compared to the reference aircraft, the DOC reduction is 15.3 %. Compared to the optimized standard version of the reference aircraft, a braced wing configuration brings an additional improvement in DOC of 3.8 %.

**Table 9.6** Results of experiment B20b-DOC

Varied parameters	Domain of variation		Optimal parameter combination	Main outputs and their relative improvement compared to A320-200			
	Low limit	High limit		$m_{MTO}$ [kg] %	$m_F$ [kg] %	DOC [US\$/NM/t] %	DOC+AV [-] %
$m_{ML} / m_{MTO}$	0.83	1	0.89				
$C_{L,max,L,unswept}$	2	3.4	3.40				
$C_{L,max,TO,unswept}$	2	3.4	3.37				
$\varphi_{25}$ [°]	0	35	16.1				
$\lambda$	0.15	0.5	0.17				
$BPR$	5	30	9.24				
$z_{P,min}/D_N$	0.1	0.3	0.12				
$SP$	0.711	0.813	0.712	59479.8	9042.4	1.238	8.13
$w_{aisle}$	0.200	0.610	0.208				
$w_{seat}$	0.437	0.533	0.438	- 19.08 %	- 30.4 %	- 15.26 %	+ 36.11 %
$w_{armrest}$	0.040	0.060	0.041				
$s_{clearance}$	0.007	0.020	0.008				
$n_{SA}$	4	8	6				
$A$ - span limit 52 m	6	35	18.8				
$s_{LFL}$ [m]	1000	2700	1889.9				
$s_{TOFL}$ [m]	1000	2700	2691.2				
$M_{CR}$	0.55	0.85	0.73				

### 9.2.3 Case C: Configuration with Natural Laminar Flow on Wings

The effect of NLF is not that significant for the optimized A320 configuration, compared to what braced wings bring (results in Table 9.7). Natural laminar flow is included in the calculation of friction coefficients in zero-lift drag. Zero-lift drag is about 60 % of total drag (Kroo 2001), yet wing represents about 25 % of the total wetted area, hence the effect of NLF cannot be substantial. This is why in the next case D, both innovations – NLF and braced wing configuration, will be accounted for at the same time.

Compared to the optimized standard version (case A), NLF brings an additional improvement of 1 % in DOC, while braced wing configuration brought a 3.8 % improvement.

**Table 9.7** Results of experiment C20b-DOC

Varied parameters	Domain of variation		Optimal parameter combination	Main outputs and their relative improvement compared to A320-200			
	Low limit	High limit		$m_{MTO}$ [kg] %	$m_F$ [kg] %	DOC [US\$/NM/t] %	DOC+AV [-] %
$m_{ML} / m_{MTO}$	0.83	1	0.90				
$C_{L,max,L,unswept}$	2	3.4	3.39				
$C_{L,max,TO,unswept}$	2	3.4	2.82				
$\varphi_{25}$ [°]	0	35	12.0				
$\lambda$	0.15	0.5	0.17				
$BPR$	5	30	9.81				
$z_{P,min}/D_N$	0.1	0.3	0.12				
$SP$	0.711	0.813	0.713	61812.51	8886.26	1.285	8.15
$w_{aisle}$	0.200	0.610	0.206				
$w_{seat}$	0.437	0.533	0.440	- 15.9 %	- 31.6 %	- 12.03 %	+ 36.35 %
$w_{armrest}$	0.040	0.060	0.042				
$s_{clearance}$	0.007	0.020	0.012				
$n_{SA}$	4	8	6				
$A$ - span limit 52 m	6	35	14.7				
$s_{LFL}$ [m]	1000	2700	1596.8				
$s_{TOFL}$ [m]	1000	2700	2693.3				
$M_{CR}$	0.55	0.85	0.72				

## 9.2.4 Case D: Configuration with Braced Wings and Natural Laminar Flow on Wings

When applying both innovations, the results are consistently better (4.4 % improvement in DOC compared to the standard version). An improvement of 4.8 % would have been expected. However, there are aerodynamic consequences when *coupling* two technologies, compared to the case when each technology is implemented separately. The effect of the braced wing is dominant. A substantial fuel reduction is observed, although the objective was minimum DOC. High aerodynamic efficiency and lower speed increase the eco-efficiency of the design.

**Table 9.8** Results of experiment D20b-DOC

Varied parameters	Domain of variation		Optimal parameter combination	Main outputs and their relative improvement compared to A320-200			
	Low limit	High limit		$m_{MTO}$ [kg] %	$m_F$ [kg] %	DOC [US\$/NM/t] %	DOC+AV [-] %
$m_{ML} / m_{MTO}$	0.83	1	0.90				
$C_{L,max,L,unswept}$	2	3.4	3.39				
$C_{L,max,TO,unswept}$	2	3.4	3.19				
$\varphi_{25}$ [°]	0	35	13.17				
$\lambda$	0.15	0.5	0.16				
$BPR$	5	30	9.1				
$z_{P,min}/D_N$	0.1	0.3	0.27				
$SP$	0.711	0.813	0.712	58807.7	8599.6	1.230	8.14
$w_{aisle}$	0.200	0.610	0.206				
$w_{seat}$	0.437	0.533	0.437	- 20.0 %	- 33.9 %	- 15.8 %	+ 36.17 %
$w_{armrest}$	0.040	0.060	0.040				
$s_{clearance}$	0.007	0.020	0.012				
$n_{SA}$	4	8	6				
$A$ - span limit 52 m	6	35	18.30				
$s_{LFL}$ [m]	1000	2700	1744.5				
$s_{TOFL}$ [m]	1000	2700	2673.4				
$M_{CR}$	0.55	0.85	0.73				

## 9.3 Optimization for Minimum $m_{MTO}$

### 9.3.1 Case A: Standard Configuration

Table 9.9 lists the results for experiment A20b-MTO, when the objective function is maximum take-off mass. Compared to DOC, where speed was important for productivity reasons, here, without this constraint, the Mach number goes toward the lower limit (the lower limit was imposed at  $M = 0.55$ ). This allows high fuel savings that very much reflect on maximum take-off weight. Concerning the rest of the parameters, the tendency is similar to DOC optimization. The sweep angle is smaller, due to a smaller speed. Compared to the results of DOC optimization, when the objective is  $m_{MTO}$ , then an additional 4 % of mass reduction is achieved (from 16 % to 20 %). The DOC reduction is smaller also by about 4 % (from 11 % to 7 %).

**Table 9.9** Results of experiment A20b-MTO

Varied parameters	Domain of variation		Optimal parameter combination	Main outputs and their relative improvement compared to A320-200			
	Low limit	High limit		$m_{MTO}$ [kg] %	$m_F$ [kg] %	DOC [US\$/NM/t] %	DOC+AV [-] %
$m_{ML} / m_{MTO}$	0.83	1	0.9				
$C_{L,max,L,unswept}$	2	3.4	3.39				
$C_{L,max,TO,unswept}$	2	3.4	3.37				
$\varphi_{25}$ [°]	0	35	8.37				
$\lambda$	0.15	0.5	0.16				
$BPR$	5	30	12.56				
$z_{P,min}/D_N$	0.1	0.3	0.106				
$SP$	0.711	0.813	0.712	58740.6	8192.5	1.353	7.83
$w_{aisle}$	0.200	0.610	0.203				
$w_{seat}$	0.437	0.533	0.437	- 20.08 %	- 37.0 %	- 7.41 %	+ 33.15 %
$w_{armrest}$	0.040	0.060	0.040				
$s_{clearance}$	0.007	0.020	0.008				
$n_{SA}$	4	8	6				
$A$ - span limit 52 m	6	35	20.15				
$s_{LFL}$ [m]	1000	2700	1913.5				
$s_{TOFL}$ [m]	1000	2700	2695.9				
$M_{CR}$	0.55	0.85	0.553				

### 9.3.2 Case B: Configuration with Braced Wings

An even higher improvement in mass is obtained with braced wings. Results are given in Table 9.10.

The aspect ratio increase allows a maximum lift-to-drag ratio of 25.1. The speed reduction allows a lower cruise altitude, of about 9900 m, which has a good effect on climate. Sweep is reduced to about half the sweep resulted after optimizing for DOC, i.e. 7.5°. Hence, a greater surface becomes available for natural laminar flow.

The high aerodynamic efficiency, given by a resulting lift-to-drag ratio of 25.1, allows the use of a smaller and more efficient engine, with a BPR of 10.2. Correspondingly the fuel reduction is of about 40 % (compared to about 30 % that resulted from DOC optimization).

Even if the objective was  $m_{MTO}$ , the DOC reduction is still important, of almost 11 %. The maximum take-off mass reduces by about 24 %, compared to 19 % when the objective is DOC.

**Table 9.10** Results of experiment B20b-MTO

Varied parameters	Domain of variation		Optimal parameter combination	Main outputs and their relative improvement compared to A320-200			
	Low limit	High limit		$m_{MTO}$ [kg] %	$m_F$ [kg] %	DOC [US\$/NM/t] %	DOC+AV [-] %
$m_{ML} / m_{MTO}$	0.83	1	0.90				
$C_{L,max,L,unswept}$	2	3.4	3.40				
$C_{L,max,TO,unswept}$	2	3.4	3.38				
$\varphi_{25}$ [°]	0	35	7.5				
$\lambda$	0.15	0.5	0.22				
$BPR$	5	30	10.23				
$z_{P,min}/D_N$	0.1	0.3	0.11				
$SP$	0.711	0.813	0.712	55883.5	7755.5	1.302	8.14
$w_{aisle}$	0.200	0.610	0.207				
$w_{seat}$	0.437	0.533	0.437	- 23.97 %	- 40.3 %	- 10.89 %	+ 36.24 %
$w_{armrest}$	0.040	0.060	0.040				
$s_{clearance}$	0.007	0.020	0.008				
$n_{SA}$	4	8	6				
$A$ - span limit 52 m	6	35	25.1				
$s_{LFL}$ [m]	1000	2700	1761.5				
$s_{TOFL}$ [m]	1000	2700	2693.1				
$M_{CR}$	0.55	0.85	0.555				

### 9.3.3 Case C: Configuration with Natural Laminar Flow on Wings

The presence of natural laminar flow on wings has a smaller impact on aircraft design efficiency compared to the braced-wing configuration. The improvements are smaller, but still important.

The maximum take-off mass reduction is of about 20.6 % – less by about 3.5 % compared to the reduction offered by a braced wing configuration. DOC is reduced by 8 % and fuel mass by 38 %.

The smaller speed allows lower altitude and thus a higher by-pass ratio engine, with  $BPR = 13.2$ . Fuel mass is reduced, due to the higher span permission and higher aspect ratio. It also favors a reduced sweep angle, even more reduced then when employing strut braced wings. Cabin parameters move again towards lower boundaries while the fuselage slenderness about 10.7.

**Table 9.11** Results of experiment C20b-MTO

Varied parameters	Domain of variation		Optimal parameter combination	Main outputs and their relative improvement compared to A320-200			
	Low limit	High limit		$m_{MTO}$ [kg] %	$m_F$ [kg] %	DOC [US\$/NM/t] %	DOC+AV [-] %
$m_{ML} / m_{MTO}$	0.83	1	0.9				
$C_{L,max,L,unswept}$	2	3.4	3.39				
$C_{L,max,TO,unswept}$	2	3.4	3.29				
$\varphi_{25}$ [°]	0	35	5.37				
$\lambda$	0.15	0.5	0.16				
$BPR$	5	30	13.21				
$z_{P,min}/D_N$	0.1	0.3	0.193				
$SP$	0.711	0.813	0.711	58354.22	8025.32	1.344	7.89
$w_{aisle}$	0.200	0.610	0.211				
$w_{seat}$	0.437	0.533	0.438	- 20.61 %	- 38.3 %	- 7.99 %	+ 33.69 %
$w_{armrest}$	0.040	0.060	0.040				
$s_{clearance}$	0.007	0.020	0.008				
$n_{SA}$	4	8	6				
$A$ - span limit 52 m	6	35	18.77				
$s_{LFL}$ [m]	1000	2700	1882.4				
$s_{TOFL}$ [m]	1000	2700	2683.6				
$M_{CR}$	0.55	0.85	0.553				

### 9.3.4 Case D: Configuration with Braced Wings and Natural Laminar Flow on Wings

When both braced wings and natural laminar flow are added to the design, the maximum take-off mass reduction compared to the original A320-200 aircraft is 22.4 %. DOCs in this case are reduced by 11.1 %.

It may be observed that the substantial mass reduction does not reflect that much on DOCs. In fact, what we optimized were equivalent ton-mile costs, measured in US\$/NM/t of payload. If the reduction in mass and fuel is translated into more payload, then the reduction in DOC would be more visible (see the example calculation on A320 NEO in Section 4.7; the reduction in fuel was translated into either more range, or more payload).

The sweep reduction is considerably higher than in the case when the objective function was DOC. This is due to the fact that in order to obtain reduced Direct Operating Costs, a higher productivity is required. This is achieved by flying faster, which requires a higher sweep to reduce wave drag. In Table 9.12 it can be seen that the sweep is only 5.6°.

**Table 9.12** Results of experiment D20b-MTO

Varied parameters	Domain of variation		Optimal parameter combination	Main outputs and their relative improvement compared to A320-200			
	Low limit	High limit		$m_{MTO}$ [kg] %	$m_F$ [kg] %	DOC [US\$/NM/t] %	DOC+AV [-] %
$m_{ML} / m_{MTO}$	0.83	1	0.9				
$C_{L,max,L,unswept}$	2	3.4	3.37				
$C_{L,max,TO,unswept}$	2	3.4	3.17				
$\varphi_{25}$ [°]	0	35	5.64				
$\lambda$	0.15	0.5	0.26				
$BPR$	5	30	10.79				
$z_{P,min}/D_N$	0.1	0.3	0.11				
$SP$	0.711	0.813	0.713	55551.5	7621.8	1.298	8.15
$w_{aisle}$	0.200	0.610	0.217				
$w_{seat}$	0.437	0.533	0.439	- 24.42 %	- 41.4 %	- 11.12 %	+ 36.37 %
$w_{armrest}$	0.040	0.060	0.040				
$s_{clearance}$	0.007	0.020	0.012				
$n_{SA}$	4	8	6				
$A$ - span limit 52 m	6	35	22.2				
$s_{LFL}$ [m]	1000	2700	1669.5				
$s_{TOFL}$ [m]	1000	2700	2696.1				
$M_{CR}$	0.55	0.85	0.551				

## 9.4 Optimization for Minimum $m_F$

### 9.4.1 Case A: Standard Configuration

The low boundary for cruise Mach number for minimum fuel was initially set to 0.1, in order to see if the optimizer still finds the optimum towards the low boundary. It was expected for Cruise Mach number in this case not to drop below 0.3, which is the compressibility Mach number that enters in the Oswald efficiency factor estimation. This expectation was fulfilled. The optimal speed chosen by the optimizer when only aircraft parameters were varied was 0.47. This allowed a substantial increase in by-pass ratio and thus an increase in aerodynamic efficiency. However, this very much reflected on costs, which increased by 10 %. The resulting extreme design was a consequence of the allowed freedom.

Table 9.13 gathers the results of varying all parameters, including cabin parameters, but with a set lower boundary for cruise Mach number of 0.55, as previously. The consequence of varying cabin parameters along with aircraft parameters is that instead of DOC increase, a design that is even cheaper by 0.4 % is obtained. Cabin parameters do not need to reach the



lower boundaries. A secondary effect of an optimization for ecological benefits due to minimizing fuel mass is a slightly improved degree of passenger comfort.

Although comfort standards increased, the value of the DOC + Added Values function decreases. This is due to the fact that the DOC improvement is not that high anymore. Since DOCs have the highest weighting in this function, the improvement is consequently small.

High by-pass ratio and low speed contribute to a reduction in cruise altitude (to about 10000 m). In fact, the optimal BPR varies with speed, and is higher with lower altitude.

The standard version of the A320 aircraft, with a span limitation increased up to 52 meters reaches an aspect ratio of 34.8 and a lift-to-drag ratio of 29.04. The aircraft is similar to a glider, hence the fuel efficiency almost doubles, reaching a reduction of almost 46 %.

**Table 9.13** Results of experiment A20b-MF

Varied parameters	Domain of variation		Optimal parameter combination	Main outputs and their relative improvement compared to A320-200			
	Low limit	High limit		$m_{MTO}$ [kg] %	$m_F$ [kg] %	DOC [US\$/NM/t] %	DOC+AV [-] %
$m_{ML} / m_{MTO}$	0.83	1	0.92				
$C_{L,max,L,unswept}$	2	3.4	3.38				
$C_{L,max,TO,unswept}$	2	3.4	3.37				
$\varphi_{25}$ [°]	0	35	9.8				
$\lambda$	0.15	0.5	0.25				
BPR	5	30	15.5				
$z_{P,min}/D_N$	0.1	0.3	0.24				
SP	0.711	0.813	0.712	63407.03	7053.5	1.455	4.08
$w_{aisle}$	0.200	0.610	0.205				
$w_{seat}$	0.437	0.533	0.438	- 13.73 %	- 45.7 %	- 0.40	- 4.34 %
$w_{armrest}$	0.040	0.060	0.040				
$s_{clearance}$	0.007	0.020	0.013				
$n_{SA}$	4	8	6				
A - span limit 52 m	6	40	34.8				
$s_{LFL}$ [m]	1000	2700	2106.2				
$s_{TOFL}$ [m]	1000	2700	2493.4				
$M_{CR}$	0.55	0.85	0.55				

### 9.4.2 Case B: Configuration with Braced Wings

The effect of the braced wings, coupled with the higher by-pass ratio engine, allowed by the low speed and high aerodynamic efficiency, brings an even greater reduction in fuel. The fuel mass reduction produced with an optimized configuration, with braced wings is 47.6 % compared to the original reference aircraft. From the 47.6 %, the fuel reduction produced by the braced wing itself and its consequences, is about 2 %.

The maximum take-off mass reduction is higher than in case A by about 5 %, thus DOCs also gain an advantage of about 4 %. As a consequence, the DOC+ AV function also improves.

**Table 9.14** Results of experiment B20b-MF

Varied parameters	Domain of variation		Optimal parameter combination	Main outputs and their relative improvement compared to A320-200			
	Low limit	High limit		$m_{MTO}$ [kg] %	$m_F$ [kg] %	DOC [US\$/NM/t] %	DOC+AV [-] %
$m_{ML} / m_{MTO}$	0.83	1	0.92				
$C_{L,max,L,unswept}$	2	3.4	3.39				
$C_{L,max,TO,unswept}$	2	3.4	2.89				
$\varphi_{25}$ [°]	0	35	11.9				
$\lambda$	0.15	0.5	0.24				
$BPR$	5	30	15.0				
$z_{P,min}/D_N$	0.1	0.3	0.16				
$SP$	0.711	0.813	0.713	59604.47	6808.51	1.391	6.30
$w_{aisle}$	0.200	0.610	0.201				
$w_{seat}$	0.437	0.533	0.438	- 18.91 %	- 47.6 %	- 4.76 %	+ 17.79 %
$w_{armrest}$	0.040	0.060	0.040				
$s_{clearance}$	0.007	0.020	0.009				
$n_{SA}$	4	8	6				
$A$ - span limit 52 m	6	35	34.9				
$s_{LFL}$ [m]	1000	2700	1953.8				
$s_{TOFL}$ [m]	1000	2700	2545.1				
$M_{CR}$	0.55	0.85	0.55				

### 9.4.3 Case C: Configuration with Natural Laminar Flow on Wings

Results interpretation is here similar to the rest of the cases C. As expected, the contribution of NLF is not significant, but still important, of about 2.2 % compared to the optimization of the standard A320 aircraft, with the 52 meters span limitation. As in the rest of the cases with  $m_F$  as objective, the free parameters describing propulsion, aerodynamics and cabin have expected, high values: BPR reaching 16, aspect ratio reaching 35.

**Table 9.15** Results of experiment C20b-MF

Varied parameters	Domain of variation		Optimal parameter combination	Main outputs and their relative improvement compared to A320-200			
	Low limit	High limit		$m_{MTO}$ [kg] %	$m_F$ [kg] %	DOC [US\$/NM/t] %	DOC+AV [-] %
$m_{ML} / m_{MTO}$	0.83	1	0.93				
$C_{L,max,L,unswept}$	2	3.4	3.38				
$C_{L,max,TO,unswept}$	2	3.4	3.26				
$\varphi_{25}$ [°]	0	35	12.69				
$\lambda$	0.15	0.5	0.218				
$BPR$	5	30	15.98				
$z_{P,min}/D_N$	0.1	0.3	0.110				
$SP$	0.711	0.813	0.713	63360.9	6766.3	1.453	4.18
$w_{aisle}$	0.200	0.610	0.204				
$w_{seat}$	0.437	0.533	0.437	- 13.79 %	- 47.9 %	- 0.54 %	- 3.42 %
$w_{armrest}$	0.040	0.060	0.041				
$s_{clearance}$	0.007	0.020	0.011				
$n_{SA}$	4	8	6				
$A$ - span limit 52 m	6	35	34.98				
$s_{LFL}$ [m]	1000	2700	1910.7				
$s_{TOFL}$ [m]	1000	2700	2415.0				
$M_{CR}$	0.55	0.85	0.552				

#### 9.4.4 Case D: Configuration with Braced Wings and Natural Laminar Flow on Wings

Coupling NLF with braced wings brings substantial advantage to fuel mass: up to 49.7 % compared to the original A320-200 aircraft. Remark: the aspect ratio was limited to 40 and the cruise Mach number was limited to 0.55. Tests with even higher boundaries were performed (aspect ratio of 55, which is the maximum possible for a span limitation of 52 m, and Mach number of 0.3, which is the compressibility Mach number, that limits the Oswald efficiency equation). For maximum fuel savings, the design moves towards these extremes, reaching even greater savings than those listed in Table 9.16. Nevertheless, such a design would be unfeasible, due to a large penalty in costs.

**Table 9.16** Results of experiment D20b-MF

Varied parameters	Domain of variation		Optimal parameter combination	Main outputs and their relative improvement compared to A320-200			
	Low limit	High limit		$m_{MTO}$ [kg] %	$m_F$ [kg] %	DOC [US\$/NM/t] %	DOC+AV [-] %
$m_{ML} / m_{MTO}$	0.83	1	0.92				
$C_{L,max,L,unswept}$	2	3.4	3.36				
$C_{L,max,TO,unswept}$	2	3.4	3.23				
$\varphi_{25}$ [°]	0	35	7.55				
$\lambda$	0.15	0.5	0.35				
$BPR$	5	30	15.18				
$z_{P,min}/D_N$	0.1	0.3	0.26				
$SP$	0.711	0.813	0.713	59656.3	6537.6	1.391	6.46
$w_{aisle}$	0.200	0.610	0.206				
$w_{seat}$	0.437	0.533	0.438	- 18.83 %	- 49.7 %	- 4.77 %	+ 19.39 %
$w_{armrest}$	0.040	0.060	0.040				
$s_{clearance}$	0.007	0.020	0.008				
$n_{SA}$	4	8	6				
$A$ - span limit 52 m	6	35	34.96				
$s_{LFL}$ [m]	1000	2700	1739.4				
$s_{TOFL}$ [m]	1000	2700	2076.3				
$M_{CR}$	0.55	0.85	0.552				

## 9.5 Optimization for Maximum DOC and Added Values Composed Function

### 9.5.1 Case A: Standard Configuration

The weightings of this objective function increase the importance of higher speed, lower landing and take-off field length, higher comfort standards and better ground handling. These constraints change the design compared to the other cases as indicated in Table 9.17. Cruise Mach number reaches 0.70 and cabin comfort parameters increase. The fuselage slenderness is 11, the aspect ratio is 16.3.

The substantial improvement of DOC + AV function (of about 41 %), also reflects on the rest of meaningful parameters: maximum take-off mass reduces by 12.8 %, fuel mass by 28.6 % and Direct Operating Costs, which represent 75 % of the DOC + AV function, are reduced by 8.5 %.

**Table 9.17** Results of experiment A20b-DOC+AV

Varied parameters	Domain of variation		Optimal parameter combination	Main outputs and their relative improvement compared to A320-200			
	Low limit	High limit		$m_{MTO}$ [kg] %	$m_F$ [kg] %	DOC [US\$/NM/t] %	DOC+AV [-] %
$m_{ML} / m_{MTO}$	0.83	1	0.91				
$C_{L,max,L,unswept}$	2	3.4	3.25				
$C_{L,max,TO,unswept}$	2	3.4	3.14				
$\varphi_{25}$ [°]	0	35	11.9				
$\lambda$	0.15	0.5	0.19				
BPR	5	30	9.79				
$z_{P,min}/D_N$	0.1	0.3	0.11				
SP	0.711	0.813	0.809	64102.79	9281.39	1.34	8.61
$w_{aisle}$	0.200	0.610	0.203				
$w_{seat}$	0.437	0.533	0.440	- 12.79 %	- 28.6 %	- 8.53 %	+ 40.90 %
$w_{armrest}$	0.040	0.060	0.060				
$s_{clearance}$	0.007	0.020	0.015				
$n_{SA}$	4	8	6				
A - span limit 52 m	6	35	16.3				
$s_{LFL}$ [m]	1000	2700	1930.7				
$s_{TOFL}$ [m]	1000	2700	2681.7				
$M_{CR}$	0.55	0.85	0.70				

### 9.5.2 Case B: Configuration with Braced Wings

By adding braced wings, aerodynamic efficiency increases and mass reduces. The improvement of the objective DOC + AV function is about 46.9 %, up to the score of 9.2.

The better aerodynamic efficiency allows landing and take-off field lengths to be reduced, thus gaining more points for the objective function.

Fuselage slenderness in case A is 11. From the parameter combination listed in Table 9.18, a smaller slenderness, of 10 results for case B. The reason is that the optimization favors a design with a higher fuselage diameter, in order to increase comfort standards. As such, the width of the seat, and also the width of the aisle, are higher.

To increase productivity the Mach number increases up to 0.80. The DOCs are reduced by 8.5 %, but also the maximum take-off mass, by 7.8 %, and the fuel mass, by 11.6 %. As a consequence of the higher speed and altitude, the BPR is only 7.5.

**Table 9.18** Results of experiment B20b-DOC+AV

Varied parameters	Domain of variation		Optimal parameter combination	Main outputs and their relative improvement compared to A320-200			
	Low limit	High limit		$m_{MTO}$ [kg] %	$m_F$ [kg] %	DOC [US\$/NM/t] %	DOC+AV [-] %
$m_{ML} / m_{MTO}$	0.83	1	0.89				
$C_{L,max,L,unswept}$	2	3.4	3.40				
$C_{L,max,TO,unswept}$	2	3.4	3.32				
$\varphi_{25}$ [°]	0	35	17.4				
$\lambda$	0.15	0.5	0.15				
$BPR$	5	30	7.5				
$z_{P,min}/D_N$	0.1	0.3	0.16				
$SP$	0.711	0.813	0.789	67744.0	11494.3	1.336	9.20
$w_{aisle}$	0.200	0.610	0.253				
$w_{seat}$	0.437	0.533	0.505	- 7.83 %	- 11.6 %	- 8.54 %	+ 46.87 %
$w_{armrest}$	0.040	0.060	0.046				
$s_{clearance}$	0.007	0.020	0.014				
$n_{SA}$	4	8	6				
$A$ - span limit 52 m	6	35	15.6				
$s_{LFL}$ [m]	1000	2700	1606.4				
$s_{TOFL}$ [m]	1000	2700	2267.3				
$M_{CR}$	0.55	0.85	0.80				

### 9.5.3 Case C: Configuration with Natural Laminar Flow on Wings

The same conclusion as in the previous C cases is valid: compared to the respective A case, the improvement is not substantial, but is beneficial, in the range of 2 %. The particularity here is that the sweep is smaller than in case B and that  $M = 0.71$ , instead of 0.8, which allows a fairly higher reduction in fuel mass.

**Table 9.19** Results of experiment C20b-DOC+AV

Varied parameters	Domain of variation		Optimal parameter combination	Main outputs and their relative improvement compared to A320-200			
	Low limit	High limit		$m_{MTO}$ [kg] %	$m_F$ [kg] %	DOC [US\$/NM/t] %	DOC+AV [-] %
$m_{ML} / m_{MTO}$	0.83	1	0.9				
$C_{L,max,L,unswept}$	2	3.4	3.4				
$C_{L,max,TO,unswept}$	2	3.4	3.2				
$\varphi_{25}$ [°]	0	35	11.2				
$\lambda$	0.15	0.5	0.19				
$BPR$	5	30	10.6				
$z_{P,min}/D_N$	0.1	0.3	0.18				
$SP$	0.711	0.813	0.812	64933.4	8909.1	1.1337	8.67
$w_{aisle}$	0.200	0.610	0.235				
$w_{seat}$	0.437	0.533	0.451	- 11.66 %	- 31.5%	- 8.46 %	+ 41.52 %
$w_{armrest}$	0.040	0.060	0.060				
$s_{clearance}$	0.007	0.020	0.017				
$n_{SA}$	4	8	6				
$A$ - span limit 52 m	6	35	17.6				
$s_{LFL}$ [m]	1000	2700	1764.5				
$s_{TOFL}$ [m]	1000	2700	2638.5				
$M_{CR}$	0.55	0.85	0.71				

## 9.5.4 Case D: Configuration with Braced Wings and Natural Laminar Flow on Wings

**Table 9.20** Results of experiment D20b-DOC+AV

Varied parameters	Domain of variation		Optimal parameter combination	Main outputs and their relative improvement compared to A320-200			
	Low limit	High limit		$m_{MTO}$ [kg] %	$m_F$ [kg] %	DOC [US\$/NM/t] %	DOC+AV [-] %
$m_{ML} / m_{MTO}$	0.83	1	0.94				
$C_{L,max,L,unswept}$	2	3.4	3.26				
$C_{L,max,TO,unswept}$	2	3.4	3.16				
$\phi_{25}$ [°]	0	35	21.7				
$\lambda$	0.15	0.5	0.17				
$BPR$	5	30	7.25				
$z_{P,min}/D_N$	0.1	0.3	0.23				
$SP$	0.711	0.813	0.811	67628.7	11306.6	1.336	9.31
$w_{aisle}$	0.200	0.610	0.205				
$w_{seat}$	0.437	0.533	0.486	- 8.0 %	- 13.0 %	- 8.6 %	+ 47.96 %
$w_{armrest}$	0.040	0.060	0.059				
$s_{clearance}$	0.007	0.020	0.018				
$n_{SA}$	4	8	6				
$A$ - span limit 52 m	6	35	13.44				
$s_{LFL}$ [m]	1000	2700	1791.8				
$s_{TOFL}$ [m]	1000	2700	2240.2				
$M_{CR}$	0.55	0.85	0.80				

## 9.6 Influence of Cabin Parameters

One of the objectives of this work was to understand the contribution of cabin parameters to the optimal design and to see how the aircraft design as a whole is influenced by cabin requirements (see Research Question 2).

A “classic design rule” states that for manufacturing reasons it is important to keep the same cross-section for one aircraft family. This rule was followed at Airbus for example with the single aisle cross-section for the A318, A319, A320 und A320 and with the twin aisle wide body aircraft A300, A310, A330 and A340 aircraft having each the same cross-section and hence also comfort level with the same number of seats abreast in economy class. A similar situation exists at Boeing, where the B707, B727, B737 and B757 all share the same fuselage cross-section (Jackson 2007). As such, there is little room for optimization during design of a



new aircraft as part of such a wider family of aircraft as the fuselage cross-section would be given a design start.

The aircraft that really broke with the “classic design rule” was the Airbus A350 XWB. Although being an offspring from the Airbus wide body family, the cross-section was enlarged for reason of cabin comfort (**Kingsley-Jones 2010**). To what extent this new cross-section is the result of a management decision aiming to answer to airline requirements, and to what extent the new cross-section is the result of formal optimization, is unknown. In any case the A350 XWB shows that a variation in cross-section is possible and can be made the subject of optimization.

OPerA supports the two possible fundamental approaches for Cabin Design and Optimization:

- 1.) Cabin parameters are *fixed* – the fuselage is a result of the *predefined* cabin parameters, no matter the consequences on aircraft performance.
- 2.) Cabin parameters are *free* – the fuselage is a result of *optimized* cabin parameters based on a selected objective function (minimum DOC or maximum DOC+AV).

In the first case, comfort standards are preset based on airline requirements or the manufacturer’s choice. In general such predefined parameters are already based on an intuitive compromise of what is desirable and what is feasible. However, in an extreme case, predefined cabin parameters could also be based on an unrestrained comfort wish list and the notion that the aircraft has to be designed such to provide the shell for the envisaged interior. This extreme design approach is known as a “design from inside out”.

In the second case, a DOC optimization would deliver the minimum measures of accepted cabin comfort standards. As such, the optimization results are not calculated but are the preset lower limits for the optimization. This work aims to deliver cabin parameters as the results of an optimization rather than to reproduce given parameters. This can be achieved with a balanced view on economics and ergonomics. The work proposes a new objective function as a combination of Direct Operating Costs (DOC) and Added Values (AV) – in short: DOC+AV.

The experiments presented in the previous sections include cabin parameters in the formal optimization process (experiments 20b<sup>1</sup>). All cabin parameters are included in the calculations and reflect on the aircraft performance (e.g.  $n_{SA}$  is part of the fuselage width calculation, which impacts the mass, drag, etc). Some cabin parameters are quantified as Added Values to the design (e.g. seat pitch  $SP$ , seat and aisle width, aisle height).

---

<sup>1</sup> To be reminded, experiments from series “b” have a span limitation increased to 52 m.

Table 9.21 compares the results of experiments 19b and 20b for case A (i.e. no technology included) when the objective is *minimum DOC*. 19b does not include the effect of cabin parameters, while 20b is the case with the highest design freedom.

**Table 9.21** The influence of cabin parameters on the objective function minimum DOC  
Improvements compared to A320 (objective: **minimum DOC**)

Parameter	aircraft parameters varied, cabin parameters constant (as for A320 aircraft) experiment 19b	Aircraft and cabin parameters varied experiment 20b	Difference
$m_{MTO}$	10.31 %	16.16 %	5.85 %
$m_F$	23.47 %	29.55 %	6.08 %
DOC	7.08 %	11.44 %	4.36 %
<b>Average</b>			<b>5.43 %</b>
DOC+AV	34.36 %	36.25 %	1.88 %

An average improvement of 5.4 % can be observed for the main outputs when varying both aircraft and cabin parameters. More precisely, by adding cabin parameters, i.e. even more design flexibility, additional improvements of 5.9 % for  $m_{MTO}$ , 6.1 % for  $m_F$  and 4.4 % for DOC are obtained.

We can notice in Table 9.21 that the impact on DOC+AV is not that high (increase of only 1.9 %). The reason is simple. On the one hand, the objective in this example was minimum DOC. DOC represent 75 % of the DOC+AV function. In this context, compared to the original aircraft, which gives already an average comfort, not much more can be added. On the contrary, since the objective function is DOC, comfort is reduced by optimization for DOC reducing in part DOC+AV results. Table 9.22 gives more details.

**Table 9.22** Cabin parameters when optimizing for minimum DOC and when optimizing for maximum DOC+AV (experiment 20b, case A)

Parameter	Low limit	High limit	Minimum DOC	Tendency DOC	Maximum DOC+AV	Tendency DOC+AV
$SP$	0.711	0.813	0.712	min	<b>0.809</b>	max
$W_{aisle}$	0.200	0.610	0.209	min	<b>0.203</b>	min
$W_{seat}$	0.437	0.533	0.437	min	<b>0.440</b>	min
$W_{armrest}$	0.040	0.060	0.041	min	<b>0.060</b>	max
$S_{clearance}$	0.007	0.020	0.012	min (?)	<b>0.015</b>	max (?)
$n_{SA}$	4	8	6		<b>6</b>	
$\lambda_F$			10.66		<b>11.00</b>	

As expected, *when optimizing for DOC the tendency is towards minimum comfort standards* with all cabin parameters going towards their minimum values. The fact that the values do not reach exactly the low limit is caused by the optimizer that would need more iterations to find the exact limit values. The optimizer had especially difficulties finding the limit value of the side wall clearance. This is due to the fact that the side wall clearance is only some mm causing a small change in the DOC results. Optimizing DOC makes sense more on a

predefined cabin, unless the airline is happy with minimum standards, in which case the airline would save money (see Table 9.21).

When optimizing for DOC+AV, some of the cabin parameters go towards minimum whereas other values go towards maximum values (see Table 9.22). This tendency is the result of the optimization between benefits of AV points for comfort and the burden in drag and mass caused by the increased size of the fuselage resulting from selected comfort measures. Again, the fact that the values do not reach exactly the low or high limit is caused by the optimizer that would need more iterations to find the exact limit values.

In the case “minimum DOC” the fuselage slenderness is  $\lambda_F = 10.7$ , while in the case “maximum DOC+AV”,  $\lambda_F = 11.0$ . It seems that “maximum DOC+AV” drive fuselage slenderness rather to higher values. In other words DOC+AV cause the fuselage rather to be longer than wider.

In order to understand better, why some cabin parameters are driven by DOC+AV to their low or high limits, the *benefit-to-burden ratio* given as weighted points per millimeter – “millimeter length” for SP and “millimeter width” for the rest of the cabin parameters – is calculated for each cabin parameter. The effect of each cabin parameter on aircraft performance is evaluated in the frame of the balanced compendium of equations contained in OPerA. Table 9.23 presents a summary of these quantifications based on values in Table 9.22.

**Table 9.23** Benefit over burden for cabin parameters

Parameter	Low limit	High limit	Min. DOC	Max. DOC+AV	Burden [m]	Actual burden [m]	Benefit [weighted points]	Benefit / Burden [points /mm]	Tendency from opt. results
<i>SP</i>	0.711	0.813	0.712	<b>0.809</b>	0.102	3.060	33.00	<b>0.108</b>	max
<i>w<sub>aisle</sub></i>	0.200	0.610	0.209	<b>0.203</b>	0.410	0.410	5.50	<b>0.134</b>	min
<i>w<sub>seat</sub></i>	0.437	0.533	0.437	<b>0.440</b>	0.096	0.576	22.00	<b>0.382</b>	min
<i>w<sub>armrest</sub></i>	0.040	0.060	0.041	<b>0.060</b>	0.020	0.160	11.00	<b>0.688</b>	max
<i>s<sub>clearance</sub></i>	0.007	0.020	0.012	<b>0.015</b>	0.013	0.026	2.80	<b>1.077</b>	max

*Burden* is calculated as the difference between high and low limits. *Actual burden* is the burden of each parameter multiplied by the number of times the respective item is found in the cabin (30 for SP, 1 for *w<sub>aisle</sub>*, 6 for *w<sub>seat</sub>*, 8 for *w<sub>armrest</sub>* and 2 for *s<sub>clearance</sub>*). *Benefit* represents the weighted points, i.e. the weights attributed to each Added Value multiplied by 10 (which is the maximum amount of points an AV can be awarded and represents the difference between the low and high limit).

The values of the *benefit-to-burden ratio* for aisle width and seat width are low, which means their impact is small, therefore the tendency towards minimum values is present. On the contrary for the armrest width and sidewall clearance, these values are high, therefore the tendency towards maximum values is present. Seat pitch also has a small value, but the

millimeters are “millimeters of aircraft length”. In comparison with “millimeters of aircraft width” the slenderness ratio should be kept in mind. Hence, an additional unit of fuselage length is not as detrimental to DOC as an additional unit of aircraft width.

DOC+AV do not give “optimum” cabin parameters from nothing. Cabin parameters coming out of the optimization are still bound towards limit values. However in contrast to DOC as objective function, limit values reached by DOC+AV are either high or low values depending on the benefit-to-burden ratio. The conclusion is that *optimizing for maximum DOC+AV shows parameter trends in which the cabin should be developed*. Recognizing these trends should help support management decisions. Since DOC drop while optimizing for DOC+AV (see Table 9.17), DOC+AV are also a suitable objective function from an economic point of view.

Regarding technology evaluation, Table 9.24 shows values for different technologies. It can be seen that cabin parameters are sensitive to objective functions, rather than to technology.

**Table 9.24** Values of cabin parameters for different technologies, for objectives minimum DOC and maximum DOC+AV

Case		A320		A320-braced		A320-laminar		A320-braced+laminar	
Objective		DOC	DOC+AV	DOC	DOC+AV	DOC	DOC+AV	DOC	DOC+AV
Parameter	$SP$	0.712	0.809	0.712	0.789	0.713	0.812	0.712	0.811
	$w_{aisle}$	0.209	0.203	0.208	0.253	0.206	0.235	0.206	0.205
	$w_{seat}$	0.437	0.440	0.438	0.506	0.440	0.451	0.437	0.486
	$w_{armrest}$	0.041	0.060	0.041	0.046	0.042	0.060	0.040	0.059
	$S_{clearance}$	0.012	0.015	0.008	0.014	0.012	0.017	0.012	0.018
	$n_{SA}$	6	6	6	6	6	6	6	6
	$\lambda_F$	10.66	11.00	10.68	10.00	10.62	10.74	10.70	10.28
<b>Average slenderness:</b>					<b>10.60</b>				

Between the two design alternatives: 1.) starting from fixed or 2.) starting from variable cabin parameters, OPerA offers the designer the support, the transparency and the freedom required in a preliminary design stage. Depending on the objective and on airline requirement he has the flexibility to vary or to set cabin parameters constant, and to assess their impact on the design from a performance-based point of view and from a decisional one.

## 9.7 Other Interesting Results

The following plots illustrate how the objectives evolved with every technology insertion compared to the baseline aircraft, for every case analyzed before (with the highest design freedom). The baseline aircraft, A320, is represented at 100 %, while the four objectives (minimum  $m_{MTO}$ ,  $m_F$ , DOC and maximum DOC+AV) are below, respectively above 100 %.

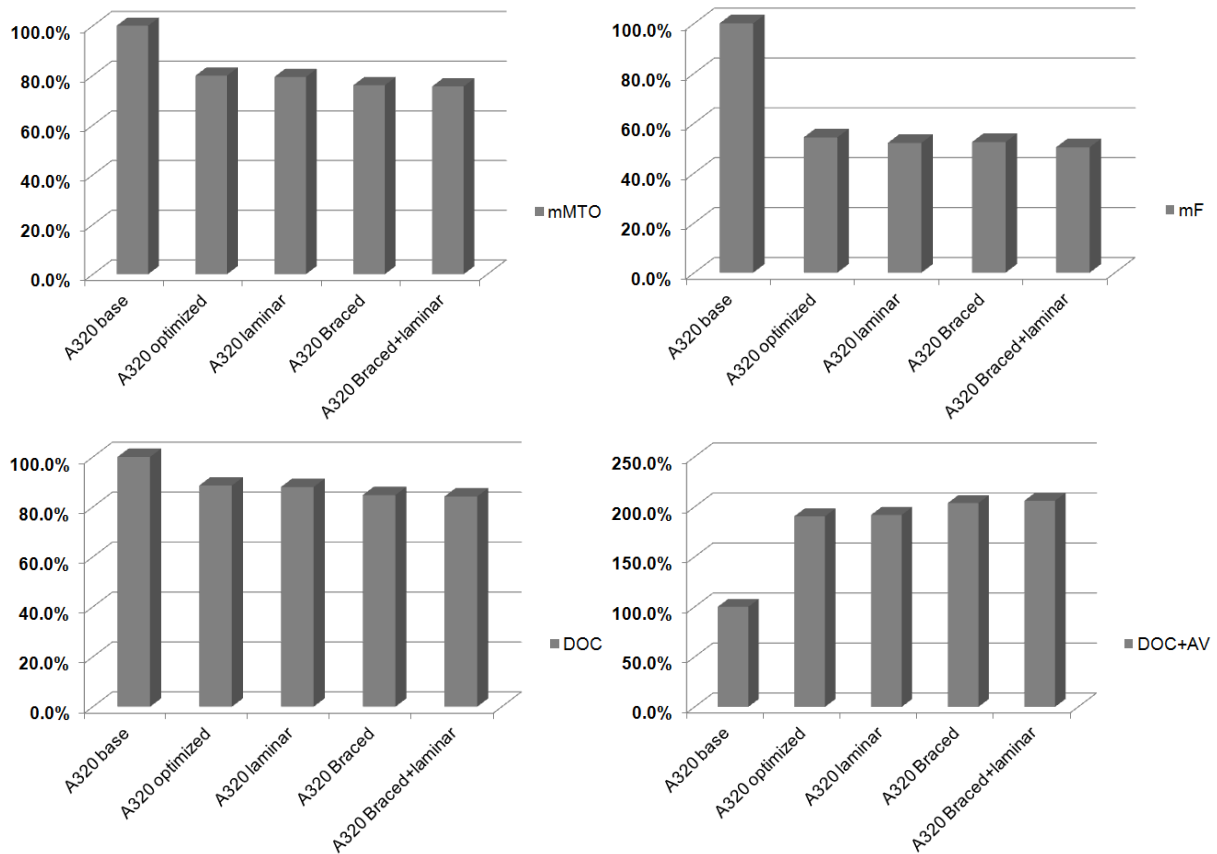

**Fig. 9.6** Improvement of each objective with increasing level of technology compared to the baseline aircraft. Each plot shows how much each of the four parameters, for each of the four case studies, is minimized ( $m_{MTO}$ ,  $m_F$ , DOC), respectively maximized (DOC+AV) compared to “A320 base”, situated at 100 %

It can be commented on that:

- There is a greater step between “A320 base” and “A320 optimized”, for all four objectives. This gap suggests there is a lot of optimization potential; however this high potential is due to the fact that the highest possible design freedom was allowed, by letting also the requirements free. When varying just design parameters, improvements are smaller, yet still important. A320 NEO lies in between.
- Improvements for objective “minimum  $m_F$ ” are higher than for the rest of the objectives. The potential of a design driven by eco-efficiency is very high due to the fact that the very influential cost constraint practically drops. A lower speed is allowed, which leads to reduced fuel mass, increased aerodynamic efficiency and all the benefits that come

from that. However, this leads to lower productivity, less revenue, and less economic efficiency, without which a design would not survive.

- For all four objectives the maximum amount of improvement is obtained when both technologies, braced wing configuration and natural laminar flow, are employed.

In order to better understand why the optimizer chose the parameter combinations in one way and not another, results have to be interpreted while looking at the whole “picture”. If parameter correlations become visible, then the output of the optimization becomes more clear and easier to interpret. Tables 9.25a and 9.25b list selected outputs for every experiment case, for the objective minimum DOC. Figure 9.7 plots the DOC improvements obtained for each experiment listed in Tables 9.25a, b.

With each, more complex, experiment, the DOC is minimized. Or, with each increase in the number of variables, the DOC improvements are higher. In other words, *the higher the design freedom, the higher the improvements that can be achieved.*

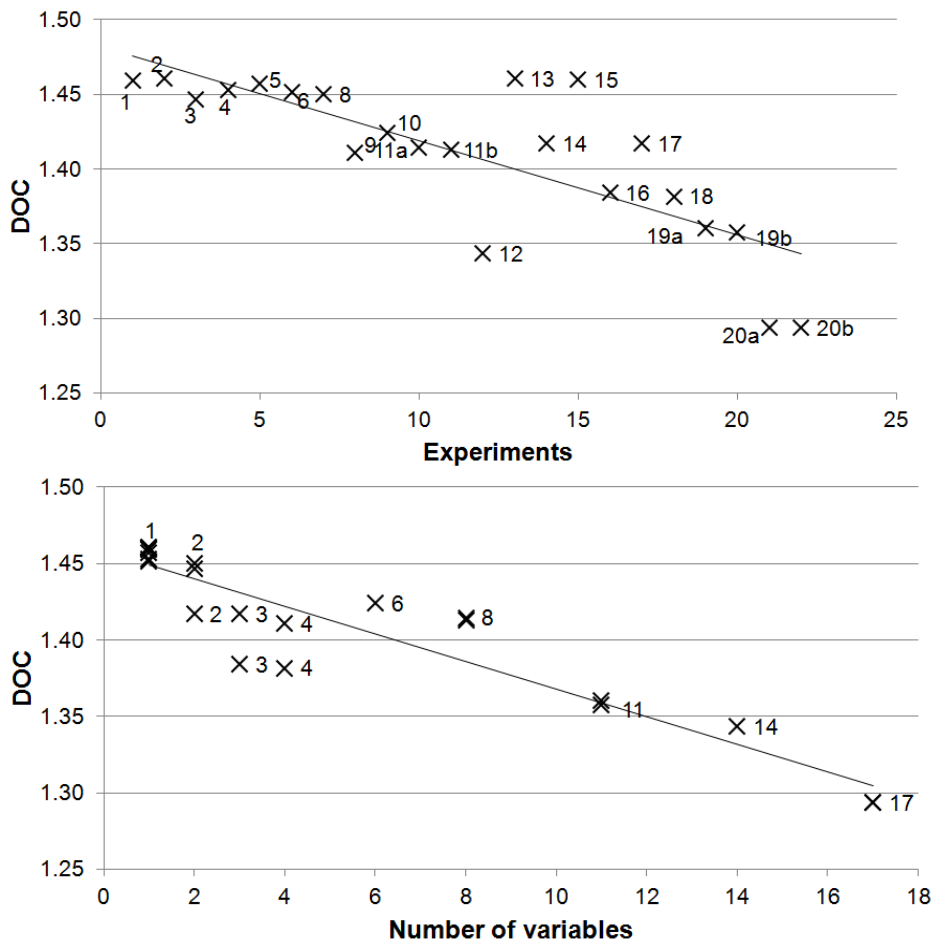

**Fig. 9.7** Improvement of objective function DOC with increasing design freedom

**Table 9.25a** List of additional outputs for study cases 1 to 12 (except case 7), objective min. DOC

Cases Axx-DOC:	1	2	3	4	5	6	8	9	10	11a	11b	12
No. of variables	1	1	2	1	1	1	2	4	6	8	8	14
<i>S<sub>LFL</sub></i>	-	-	-	-	-	-	-	-	-	-	-	-
<i>S<sub>TOFL</sub></i>	-	-	-	-	-	-	-	-	-	-	-	-
<i>M<sub>CR</sub></i>	-	-	-	-	-	-	-	-	-	-	-	-
<i>A</i>	-	8.93	-	-	-	-	-	10.42	12.48	12.27	12.80	12.77
<i>C<sub>LmaxL,unswept</sub></i>	-	-	3.40	-	-	-	-	3.40	3.39	3.39	3.40	3.39
<i>C<sub>LmaxTO,unswept</sub></i>	-	-	3.08	-	-	-	-	3.01	3.31	3.25	3.29	3.30
<i>φ<sub>25</sub></i>	-	-	-	16.26	-	-	17.10	-	18.87	16.81	14.31	16.19
<i>λ</i>	-	-	-	-	0.15	-	0.15	-	0.16	0.15	0.16	0.16
<i>z<sub>P</sub> / D<sub>N</sub></i>	-	-	-	-	-	-	-	-	-	0.10	0.12	0.11
<i>BPR</i>	-	-	-	-	-	7.02	-	-	-	8.59	9.43	8.93
<i>m<sub>ML</sub> / m<sub>MTO</sub></i>	0.92	-	-	-	-	-	-	0.88	0.88	0.89	0.89	0.89
<i>SP</i>	-	-	-	-	-	-	-	-	-	-	-	0.71
<i>w<sub>aisle</sub></i>	-	-	-	-	-	-	-	-	-	-	-	0.22
<i>w<sub>seat</sub></i>	-	-	-	-	-	-	-	-	-	-	-	0.44
<i>w<sub>armrest</sub></i>	-	-	-	-	-	-	-	-	-	-	-	0.04
<i>S<sub>clearance</sub></i>	-	-	-	-	-	-	-	-	-	-	-	0.01
<i>n<sub>SA</sub></i>	-	-	-	-	-	-	-	-	-	-	-	6.00
<b>Objective</b>												
<i>m<sub>MTO</sub> · 10<sup>3</sup></i>	73.49	73.42	72.69	72.97	73.26	72.96	72.79	70.70	71.63	71.00	71.03	66.56
<i>m<sub>F</sub> · 10<sup>3</sup></i>	12.91	13.25	12.88	13.01	12.95	12.52	12.98	12.30	11.71	11.11	10.97	10.13
<b>DOC</b>	1.46	1.46	1.45	1.45	1.46	1.45	1.45	1.41	1.42	1.41	1.41	1.34
<b>DOC+AV</b>	4.58	4.53	5.00	4.80	4.66	4.84	4.90	6.27	5.81	6.13	6.22	8.23
<b>Other Outputs</b>												
<i>m<sub>MTO</sub> / S<sub>W</sub></i>	571.1	600.5	601.1	636.1	600.5	600.5	633.3	598.2	622.2	622.2	634.3	625.5
<i>T / W</i>	0.293	0.308	0.296	0.308	0.308	0.308	0.308	0.256	0.273	0.275	0.273	0.271
<i>h<sub>CR</sub> · 10<sup>3</sup></i>	11.65	11.69	11.63	11.80	11.87	11.56	11.80	11.00	11.90	10.99	10.67	11.07
<i>V<sub>CR</sub></i>	224.3	224.3	224.3	224.3	224.3	224.3	224.3	224.3	224.3	224.3	225.4	224.3
<i>E</i>	17.76	17.00	17.56	17.31	17.51	17.54	17.32	18.38	19.88	19.55	19.71	20.51
<i>E<sub>max</sub></i>	17.77	17.11	17.60	17.50	17.61	17.57	17.50	18.44	19.88	19.71	20.04	20.62
<i>V / V<sub>md</sub></i>	0.98	0.95	0.97	0.93	0.95	0.97	0.93	1.04	1.00	1.07	1.10	1.05
<i>t / c</i>	0.13	0.12	0.12	0.09	0.12	0.12	0.09	0.13	0.10	0.10	0.10	0.10
<i>S<sub>W</sub></i>	128.7	122.3	120.9	114.7	122.0	121.5	114.9	118.2	115.1	114.1	112.0	106.4
<i>TTO</i>	105.7	111.1	105.4	110.4	110.8	110.4	110.1	88.63	96.05	95.81	95.17	88.47
<i>SFC · 10<sup>-6</sup></i>	16.59	16.50	16.59	16.51	16.50	15.84	16.51	16.94	16.77	15.49	15.39	15.60
<i>C<sub>L</sub></i>	0.68	0.72	0.71	0.77	0.74	0.70	0.77	0.64	0.77	0.67	0.65	0.68
<i>C<sub>LmaxL,swept</sub></i>	3.07	3.07	3.08	3.26	3.07	3.07	3.24	3.08	3.21	3.24	3.29	3.26
<i>C<sub>LmaxTO,swept</sub></i>	2.68	2.68	2.79	2.83	2.68	2.68	2.82	2.73	3.13	3.11	3.19	3.17
<i>C<sub>D,0</sub> · 10<sup>-3</sup></i>	18.5	18.8	18.9	19.1	18.9	18.9	19.0	18.8	19.3	19.3	19.4	18.3
<i>e</i>	0.784	0.784	0.784	0.784	0.784	0.784	0.781	0.782	0.778	0.776	0.773	0.775
<i>λ<sub>opt</sub></i>	0.176	0.176	0.176	0.245	0.176	0.176	0.237	0.176	0.222	0.240	0.263	0.245
<i>k<sub>laminar</sub></i>	0.47	0.46	0.48	0.50	0.47	0.48	0.50	0.47	0.50	0.50	0.50	0.50
<i>Re<sub>T</sub> · 10<sup>7</sup></i>	1.02	1.00	1.02	1.56	0.99	1.02	1.49	1.04	1.42	1.54	1.69	1.59
<i>λ<sub>fus</sub></i>	8.98	8.98	8.98	8.98	8.98	8.98	8.98	8.98	8.98	8.98	8.98	10.67
<i>b<sub>eff</sub></i>	34.96	33.04	33.90	33.01	34.04	33.97	33.04	35.09	37.91	37.42	37.86	36.87
<i>b<sub>geo</sub></i>	34.96	33.04	33.90	33.01	34.04	33.97	33.04	35.09	36.00	36.00	37.86	36.00
<i>A<sub>eff,lim</sub></i>	11.20	11.79	11.91	12.56	11.81	11.86	12.54	12.19	12.52	12.63	26.00	13.54
<i>A<sub>geo,lim</sub></i>	10.07	10.60	10.72	11.30	10.62	10.67	11.28	10.97	11.26	11.36	24.15	12.18
<i>h<sub>WL</sub></i>	0.00	0.00	0.00	0.00	0.00	0.00	0.00	0.00	2.34	1.74	0.00	1.06
<i>h<sub>Pmin</sub></i>	0.29	0.30	0.29	0.30	0.30	0.31	0.30	0.27	0.28	0.21	0.24	0.21

**Table 9.25b** List of additional outputs for study cases 13 to 20, objective minimum DOC

Cases Axx-DOC:	13	14	15	16	17	18	19a	19b	20a	20b		
No. of variables	1	2	1	3	3	4	11	11	17	17		
Inputs	$S_{LFL}$	-	2038	-	1798	2062	1762	2020	1825	1903	1738	
	$S_{TOFL}$	-	2661	-	2696	2691	2688	2684	2674	2695	2676	
	$M_{CR}$	-	-	0.75	-	0.76	0.75	0.70	0.71	0.70	0.70	
	$A$	8.93	-	-	12.1	-	11.8	15.8	15.2	17.4	15.0	
	$C_{LmaxL,unswept}$	-	-	-	-	-	-	3.23	3.39	3.31	3.37	
	$C_{LmaxTO,unswept}$	-	-	-	-	-	-	3.20	3.07	3.22	2.97	
	$\phi_{25}$	-	-	-	-	-	-	11.86	11.51	11.47	8.61	
	$\lambda$	-	-	-	-	-	-	0.18	0.15	0.15	0.16	
	$z_P / D_N$	-	-	-	-	-	-	0.14	0.14	0.11	0.13	
	$BPR$	-	-	-	-	-	-	10.33	10.07	10.03	9.92	
	$m_{ML} / m_{MTO}$	-	-	-	-	-	-	0.90	0.89	0.90	0.90	
	$SP$	-	-	-	-	-	-	-	-	0.71	0.71	
	$w_{aisle}$	-	-	-	-	-	-	-	-	0.21	0.21	
	$w_{seat}$	-	-	-	-	-	-	-	-	0.44	0.44	
	$w_{armrest}$	-	-	-	-	-	-	-	-	0.04	0.04	
	$s_{clearance}$	-	-	-	-	-	-	-	-	0.01	0.01	
	$n_{SA}$	-	-	-	-	-	-	-	-	6.00	6.00	
	Objective	$m_{MTO} \cdot 10^3$	73.42	70.67	72.90	69.07	70.68	68.50	65.64	65.92	61.61	61.62
		$m_F \cdot 10^3$	13.25	13.39	12.87	11.84	13.43	11.75	9.78	9.95	8.83	9.16
<b>DOC</b>		1.46	1.42	1.46	1.38	1.42	1.38	1.36	1.36	1.29	1.29	
DOC+AV		4.53	5.77	4.55	6.91	5.77	6.99	7.86	7.95	8.22	8.14	
Other Outputs	$m_{MTO} / S_W$	600.5	845.4	600.5	745.8	855.2	730.9	841.8	802.7	810.5	764.8	
	$T / W$	0.308	0.288	0.308	0.251	0.289	0.249	0.243	0.242	0.232	0.238	
	$h_{CR} \cdot 10^3$	11.69	10.91	11.89	11.06	10.89	11.00	98.93	98.98	10.28	10.11	
	$V_{CR}$	224.3	224.6	220.4	224.3	224.7	221.0	209.0	212.2	208.2	208.8	
	$E$	17.00	16.08	17.57	18.88	16.02	18.91	20.92	20.70	22.79	21.51	
	$E_{max}$	17.11	16.52	17.71	18.89	16.48	18.92	21.00	20.85	22.84	21.55	
	$V / V_{md}$	0.95	0.89	0.94	0.98	0.89	0.98	1.04	1.06	1.03	1.03	
	$t / c$	0.12	0.10	0.13	0.11	0.10	0.12	0.13	0.13	0.13	0.13	
	$S_W$	122.3	83.6	121.4	92.6	82.7	93.7	78.0	82.1	76.0	80.6	
	$TTO$	111.1	100.0	110.3	85.1	100.0	83.5	78.4	78.4	70.0	71.9	
	$SFC \cdot 10^{-6}$	16.50	16.71	16.27	17.04	16.72	16.86	14.50	14.81	14.85	14.84	
	$C_L$	0.72	0.89	0.77	0.81	0.90	0.81	0.90	0.84	0.92	0.85	
	$C_{LmaxL,swept}$	3.07	3.07	3.07	3.07	3.07	3.07	3.16	3.32	3.24	3.33	
	$C_{LmaxTO,swept}$	2.68	2.68	2.68	2.68	2.68	2.68	3.13	3.01	3.16	2.93	
	$C_{D,0} \cdot 10^{-3}$	18.8	21.4	19.1	20.7	21.5	20.7	23.5	22.7	21.6	20.9	
	$e$	0.784	0.784	0.804	0.780	0.783	0.798	0.833	0.822	0.824	0.822	
	$\lambda_{opt}$	0.176	0.176	0.176	0.176	0.176	0.176	0.288	0.292	0.293	0.326	
	$k_{laminar}$	0.46	0.50	0.50	0.50	0.50	0.50	0.50	0.50	0.50	0.50	
	$Re_T \cdot 10^7$	1.00	1.02	1.02	1.07	1.02	1.06	1.83	1.84	1.85	1.95	
	$\lambda_{fus}$	8.98	8.98	8.98	8.98	8.98	8.98	8.98	8.98	10.68	10.67	
	$b_{eff}$	33.04	28.18	33.96	33.40	28.02	33.26	35.13	35.38	36.34	34.78	
	$b_{geo}$	33.04	28.18	33.96	33.40	28.02	33.26	35.13	35.38	36.00	34.78	
	$A_{eff,lim}$	23.82	17.24	11.87	31.44	17.44	31.07	18.48	35.45	18.96	36.14	
$A_{geo,lim}$	22.12	15.50	10.68	29.20	15.68	28.85	16.62	32.93	17.05	33.56		
$h_{WL}$	0.00	0.00	0.00	0.00	0.00	0.00	0.00	0.00	0.42	0.00		
$h_{Pmin}$	0.30	0.29	0.30	0.27	0.29	0.27	0.27	0.27	0.22	0.24		





# 10 Cabin Design and Conversion in Industry

## 10.1 A Process Chain for Cabin Design

At a smaller scale, the Cabin Design reflects the process steps of Aircraft Design. Once the fuselage conception is completed, the cabin requirements for safety and operation must then be reflected in the *Cabin Architecture Development*. This section approaches Cabin Architecture Development issues and aims to determine the process steps involved by the modeling. Programming a tool for detailed Cabin Architecture after the proposed steps is, nevertheless, beyond the purpose of the work.

The Cabin Architecture needs to integrate a large amount of different systems and components:

- Cabin communication
- Entertainment system
- Air conditioning system
- Oxygen system
- Emergency floor path marking
- Lights
- Service (galley)
- Utilities (lavatories, stowage compartments)
- Seats (flight attendants and passengers)

The overall Cabin Architecture Optimization becomes an important issue. Inspired by the development of System Architecture (**Reis 2010**), the following process steps can be identified for Cabin Architecture Development in Preliminary Design stage:

- 1.) Definition of architecture components
- 2.) Definition of placement constraints
- 3.) Generation of an initial architecture
- 4.) Investigation of competing architectures
- 5.) Validation of result

The input data required when defining the Cabin Architecture (i.e. an initial Step 0) is a fuselage shape optimized with respect to cabin requirements. An optimized fuselage shape accounts for both performance-based parameters, such as fuselage drag, and comfort-based parameters, such as number of seats abreast. This shape is delivered by OPerA (see also the study in **Niță 2010**).

*Step 1.)* : Architecture components refer to items like seats, galley, lavatories or stowage bins. These items need to be geometrically defined and then linked to the fuselage inside dedicated zones.

*Step 2.)* : Placement constraints are first of all imposed by the certification authorities (e.g. no item needs to be positioned within a specified area near emergency exits). There are also placements constraints required by the operator (e.g. some of the overhead stowage bins are occupied by emergency equipment or IFE system).

*Step 3.)* : According to previously defined constraints possible architectural layouts are generated.

*Step 4.)* : Resulting architectures are compared and statements are formulated.

*Step 5.)* : In the end a valid configuration, fulfilling the constraints, is validated.

The fulfillment of the process steps enumerated above would ensure optimized placement and sizing of cabin items with respect to regulatory, geometric, volumetric constraints. For cabin conversions, that regularly occur during the aircraft life, it is important to assess the impact of cabin architectural changes on aircraft performance and cost. The effect of such changes can be assessed if a tool following Steps 1.) to 5.) would be connected to OPerA.

### **Knowledge Based Engineering in Cabin Design**

A concept that would streamline the application of Steps 1.) to 5.) is Knowledge Based Engineering (KBE). This approach uses knowledge databases and data association (**Russel 2003**) in order to automate the design process. In the case of Cabin Architecture Initial Design, (and in view of step 1.)) libraries of Cabin Architecture components may be predefined and used as built-in units together with their parametric description.

Many studies have been performed on KBE and its utility (**Russel 2003**). It is commonly agreed that Knowledge Based Engineering aims to capture and reuse product and process multidisciplinary knowledge in an integrated way. The results should reduce time and cost for engineering applications, automate repetitive design tasks (like multiple seat representation in the cabin layout), and support Conceptual Design activities. KBE allows manipulating the geometry and annexed knowledge and supports the investigation of multiple “what-if” interogations on their design.

Currently there is no tool available for a complete Cabin Architecture Development in Preliminary Design stage. An example of tool using KBE that assists the generation of (only) cabin layouts is *Pacelab Cabin*. This tool gathers technical rules, generated by customer or certification requirements, into a knowledge database. The rules can then be used, modified and updated or newly created by the user. This type of tools that allow a rapid generation of initial cabin layouts are helpful during initial discussions between Design Organizations performing cabin upgrades or conversions and their customers. It is important for the Design Organization to be able to create fast cabin layouts and show to the customer modification

alternatives. An illustration of some results obtained with this program is shown in Figure 10.1 (see also Szasz 2009).

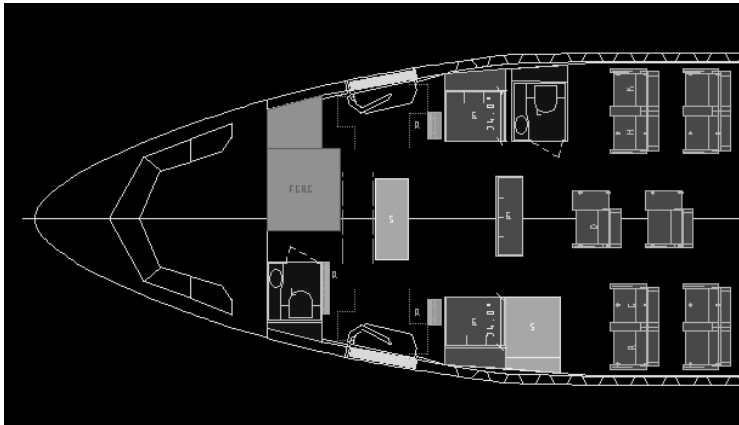

**Fig. 10.1** Cabin layout obtained with *Pacelab Cabin* tool

## 10.2 Cabin Design by Aircraft Manufacturers

The way Cabin Architecture Design is performed in industry varies from one aircraft manufacturer to another. In Europe, the major aircraft manufacturer is Airbus. Airbus produces transport aircraft for long and medium range and it has also developed the propeller driven military airlifter A400 M. Very successful in the single aisle category is the A320 family.

The procedure for creating *standard cabins* at Airbus is described in the documents called Airbus Procedures (AP), respectively *AP 2289 - Design New Cabin and Cargo (DnCC)* (**AP 2289**). The processes describing the *complete development* of the cabins are derived from the processes for aircraft development, explained in *AP 2054 - DnA – Design New Aircraft*.

The *AP 2289* indicates nine cabin development phases (**AP 2289**), as follows:

- Concept Phase
- Architecture Phase
- Definition Phase
- Design Phase
- MCA (Major Component Assembly) Preparation Phase
- FAL (Final Assembly Line) Preparation Phase
- Manufacturing & Testing Phase
- Adjustment Phase
- Final Project Phase

Each phase is divided in what Airbus calls “swim lanes” (AP 2289):

- Project Management
- Industrial Design
- Engineering Vendor Management
- Cabin & Cargo Integration
- Electrical Systems
- Mechanical Systems
- Cabin & Cargo Furnishing
- Structure Design
- Manufacturing & Assembly

For a complete Cabin *Retrofit* Design the procedure is adapted for the *Upgrade Services* organization, within Airbus.

### 10.3 Cabin Conversion by Completion Centers

While Cabin Design can be performed only by the aircraft manufacturer having the Type Certificate for the respective airplane, Cabin Retrofits or Cabin Conversions can be performed by engineering design companies different from the aircraft manufacturer that hold a Design Organization Approval (DOA) from EASA (see Section 10.7). This is the reason why transport aircraft manufacturers (like Airbus) usually adopt the strategy of outsourcing a large part of the design work on cabin retrofits. The role of subcontractors becomes important. Hence many engineering design companies seek to enlarge their activities in this area (Petscher 2009).

Such Design Organizations able to deliver certified Cabin Conversions are often found under the name *Completion Center*.

A Completion Center can deliver a range of modifications from simple cabin upgrades to complete, highly specialized conversions, usually attributed to VIP aircraft. The range of cabin conversions throughout the commercial aircraft life can be as follows:

- *At age 0*: several initial standard cabin layouts are created by the aircraft manufacturer.
- *At age 5 to 20 years*: several cyclic cabin upgrades caused by worn out furnishing or due to change of aircraft ownership are undertaken inside a Completion Center; if the owner is a VIP, the design and engineering work normally demands a complex certification process, especially if the customer is asking for unusual furnishings.
- *After age of 20 years*: the only scenario possible is pax-to-freighter conversion, undertaken either by the aircraft manufacturer or within a Completion Center.

In common understanding, the notion Completion Center, refers to those organizations able to deliver aircraft cabin conversions independent from other companies.

Lately, several other possible ways to define the term Completion Center have come into use. Accordingly, a Design Organization (DO) can call itself a Completion Center even without seeing the aircraft, by delivering only the design work. Another possibility for a company to call itself Completion Center is to conduct the work for the customers through intermediaries, as a developer. Figure 10.2 illustrates all these possibilities:

- *Possibility 1:* the Completion Center covers only the design and engineering work (D&E) itself. The work embodiment, certification and organization of the whole tasks is done by other companies. Currently engineering offices working as subcontractors for aircraft manufacturers in the area of Cabin Conversions can grow into becoming an independent Completion Center according to this definition.
- *Possibility 2:* the Completion Center covers the work embodiment while other companies are responsible for organization of all the tasks and the documentation related to design, engineering and certification.
- *Possibility 3:* the Completion Center acts as a developer. A developer works like a building project organizer or a travel agency – it has neither the capability to perform the design and engineering work nor the work embodiment, but it is able to organize these tasks for the customer through third party involvement.
- *Possibility 1+2:* the Completion Center is able to ensure both design and engineering (D&E) as well as work embodiment. Since this type of Completion Center comprises all the work necessary for the conversion itself, an independent developer is not necessary. This definition of Completion Center is the one from the industry's common understanding. It is also the most common type of Completion Center; a well known example of this type of Completion Center is Lufthansa Technik.
- *Possibility 2+3:* the Completion Center acts as a developer and has the capability to do the work embodiment itself. D&E are outsourced.
- *Possibility 3+1:* the Completion Center acts as a developer. It also has the capability to ensure the D&E work itself. The work embodiment is subcontracted to another company.

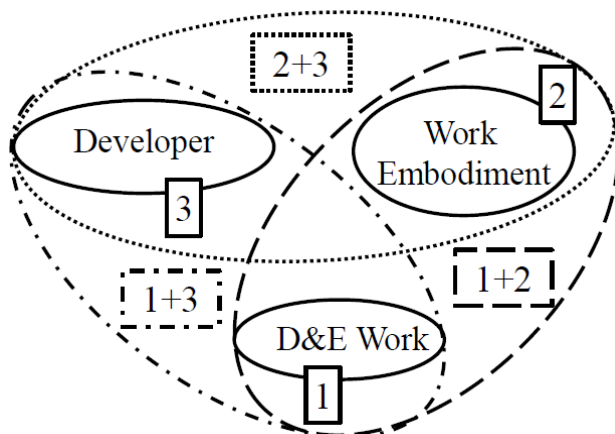

**Fig. 10.2** Completion Center concepts

When looking at the companies dealing today with Cabin Conversions, some observations can be extracted:

- A frequent scenario is VIP Completion. VIP customers are usually high paying and high demanding. VIP completion on large aircraft can result in big contracts.
- Certification work is performed under the Aviation Authorities, which usually require a certificate showing the capability of performing the design (EASA and FAA call it DOA – Design Organization Approval). However, a company can function as a Completion Center without DOA, if certification work is subcontracted.

## 10.4 A Process Chain for Cabin Conversion

The work process chain within a Completion Center is as unique as the way<sup>1</sup> each aircraft manufacturer builds its aircraft. The purpose of our research on this topic is on the one hand to illustrate the economic importance of conversions, the way they are handled in industry and the airworthiness implications of such work (Section 10). On the other hand, once this context is understood, the purpose is to propose a scientific approach to Process Chain Optimization, for Aircraft Cabin Conversions. This is covered in Section 11.

There is not just one path towards achieving an optimized process chain for Cabin Conversion. The flow of processes and documents for Cabin Conversion should be in such a way organized, that it minimizes parameters like: time, costs, effort and, especially, errors. A typical path is described below.

The first attempt to define the customer requirements is made in the *Offer Phase*. If the offer is accepted by both partners, then the technical document, describing it and the technical implications, serves as input for the *Conversion Processing*. The output of the processing, summarized in the *Hand Over Phase*, comes back to the customer, and a loop closes (see Figure 10.3).

The proposed Process Chain is divided into three parts:

- Part A, referring to the offer phase description,
- Part B, referring to the description of the processes for completing the conversion,
- Part C, describing the end processes and the outputs received from the customer.

---

<sup>1</sup> traceable up to a certain extent

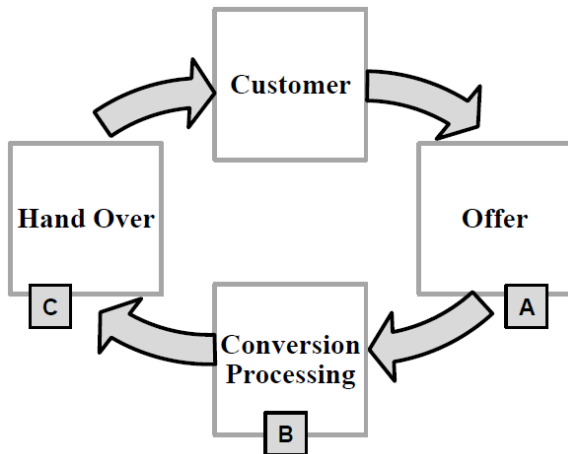

**Fig. 10.3** Process chain concept for cabin conversions

**A: Offer**

The Offer Phase starts with the Customer Request which is formalized through a preliminary document briefly describing the requirements of the customer and the implications within the Design Organization. In the same time, this document represents the first decision gate for both partners. If the two parts agree, then the Technical Offer will describe in detail the actions which are to be followed in order to finalize the customer request.

Parallel to this activity, the engineering office should make a feasibility study, to see if it is a benefit for the company to accept the proposed task from the customer. For example, it would be quite difficult to comply with the requirements from customers having products not conforming to the type certification basis. If each decision gate ends with a “yes”, the outputs enter then the Process Chain B.

**B: Conversion Processing**

The conversion cycle gathers all the phases related to the design and certification of the conversion work. These phases are:

- 1.) Concept
- 2.) Definition
- 3.) Design
- 4.) Adjustment

Each phase has its own number of sub-phases, which can also be further divided into smaller processes. Their representation and optimization is performed in Section 11.

1.) Concept Phase

The first stage in the development of a product is the conception. The actions required at the beginning of a project are mainly referring to:

- understanding and filtering the customer requirements,
- understanding and filtering the certification requirements,
- making an internal feasibility study,



- studying the design possibilities,
- organizing the work flow,
- developing the preliminary design,
- developing the testing and verification methods.

## 2.) Definition Phase

The definition phase approaches the same issues more in depth, with the purpose of achieving the final version of the design. The main steps are:

- defining the certification basis,
- defining the Means of Compliance,
- defining the process steps,
- assigning and organizing a team,
- analyzing mechanical and electrical loads, tolerances,
- analyzing interference between components,
- testing the design,
- validating the design concept.

## 3.) Design Phase

The design engineers perform the design work based on the prescriptions of a Chief of Design, assigned already in the conception phase, and those of the airworthiness engineers and Compliance Verification Engineers (CVE). Mainly, during this phase it is required to:

- perform the design according to the prescriptions elaborated during the earlier phases,
- verify the design (Design Verification Engineers),
- give feedback to the project leader.

## 4.) Adjustment Phase

The adjustment phase sums up those activities aimed to improve the overall functioning of the company delivering the conversion. Some of the processes belonging to this phase are:

- getting feedback from every engineering department,
- detecting points of improvement,
- proposing optimized solutions.

## 5.) Certification

According to CS 25.21(**CS 25**) the certification process of an aircraft means proving that the design complies with all the requirements stated in the specifications emitted by the Authority. For efficiency, the certification process should start from the early phase of the conception, in parallel to the design development activities. For reducing time and errors, certain aspects need to be already considered when the concept is developed. The certification process is under the responsibility of the Office of Airworthiness (**Part 21**). Mainly the steps are:

- establishing contact with the authorities,

- creating the means of compliance (tests and corresponding documentation),
- creating and approving the certification documentation, under DOA privileges,
- creating certification documentation for getting EASA approval (where the privileges do not apply),
- signing the declaration of compliance (responsibility of head of DO).

### **C: Hand Over**

Once the design is performed and verified, the next step is to hand over the results to the customer. The form of the results is written documentation, describing the assembly process in detail. The size and complexity of the technical documentation depends on the size of the conversion project. Besides the technical documentation, assistance should be as well provided. The steps involved in this phase require:

- taking over the final version of the design documentation,
- creating the assembly instructions, based on the design documentation,
- verifying the documentation,
- providing assistance,
- delivering the results to the customer.

The output of the finalized conversion process becomes the input for the hand over phase, and receives the name “deliverable”. Together with the deliverable, the engineering office needs to provide assistance to the customer, once the work package is finished.

Under the hypothesis that the company performs only the design work, and not the manufacture and assembly, the deliverable is in fact a document, gathering all the data necessary for the design to be executed: technical documentation, procedures and instructions for assembly, part lists, instructions and cautions for continued airworthiness and maintenance.

## **10.5 Tools in Cabin Design and Conversion**

There are several categories of tools indispensable for a Completion Center (CC):

- 1.) *Design and Engineering* (i.e. Computer Aided Design Tools – CAD) – for creating 2D and 3D layouts,
- 2.) *Analysis and Simulation* (i.e. Computer Aided Engineering – CAE) – for stress calculation and mechanical simulation,
- 3.) *Data Management* (i.e. Product Data Management – PDM) – for data archiving and administration,
- 4.) *Resources Management* (i.e. Enterprise Resources Planning – ERP) – for resources management and process optimization.

Some of the selection criteria for each category from the point of view of a Completion Center are summarized in Table 10.1.

**Table 10.1** Categories of tools and selection criteria

Category	Criteria
CAD and CAE	<i>Compatibility</i> with other types of software (CAD, CAE, PDM) or with old and future versions of the same software, <i>Operability</i> - such as duration of a medium sized task, <i>Functionalities</i> , <i>Visualization</i> capabilities – for CAD only, If it is already implemented in the CC or not.
PDM	<i>Operability</i> of the database, <i>Access management</i> for multi work and suppliers, SDM <sup>1</sup> , <i>PLM capabilities</i> , <i>Integration</i> implications (e.g. set-up duration and complexity), Supplier <i>access</i> .
ERP	<i>Functionalities</i> <i>Operability</i> <i>Integration</i> implications

<sup>1</sup> SDM – Simulation Data Management

Regarding category 1.), it must be underlined that usually the work of a Completion Center is required late in the aircraft life. This is the reason why, due to the long aircraft lifetime, data can be very old and not compatible with the standards at the time of the cabin conversion. Additionally the CAD software of a Completion Center must be compatible with other necessary software (e.g. CAE for stress calculation) and with the data format from the manufacturer. Currently CATIA®, developed by *Dassault Systems* is already established in aeronautical industry as the most common and reliable CAD software. An Added Value for a CAD tool would be to have good rendering capability. Rendering has a special significance in cabin refurbishing activities. A close cooperation with the customer is required in order to understand the requirements. Tools allowing rendering and 3D visualization play a key role during the negotiation phases, allowing time reduction in defining the preliminary design solutions.

With respect to category 2.) it must be noted that there is a huge variety of packages available from each commercial tool editor, that may include or not certain functionalities, such as: nonlinear analysis, post/pre processing, dynamics and motion, etc. Both CAD and CAE tools have been developed according to the needs of aerospace industry. This is the reason why the experience already accumulated in using them is a decisive criteria.

If the first two categories are quite well established in the industry, tools for categories 3.) and 4.) – Data Management and Resources Management are more difficult to evaluate and to implement within a Completion Center. The main reason is the high customization required to match the needs of each company.

A non-negligible criterion is the price of the licenses as well as involved expenses for each tool (e.g. investments for achieving necessary computer requirements or training). There are also certified open-source tools on the market. However, the technical capabilities should be of prime importance.

Resources Management Tools become increasingly important. Such tools, tailored on the needs of a company, can significantly increase efficiency. Attributes that would bring an Added Value are:

- Access with simple browser
- Multiuser capability (up to thousands)
- Good customization capabilities
- Automatic reading of documents
- Integration with common tools (such as *MS Office*)
- Product Lifecycle Management (PLM) capability
- Supply Chain Management capability
- Human Capital Management capability
- Travel Management capability
- Customer Relationship Management capability
- Email Center
- Ability to connect to other ERP (Enterprise Resource Planning) tools

## **10.6 Market Forecast for Cabin Conversion**

A secondary purpose of this analysis was to confirm the importance of Cabin Conversions for industry. Thus a market survey was performed with a forecasted period from present up to 2029. An interesting aspect would be to know how sensitive cabin conversions are to economical fluctuations. The market survey showed that only certain market segments are affected.

The procedure adopted to perform the forecast followed these steps (a detailed description of this work was published by the author in the Journal of Aerospace Operations, **Niță 2011**):

- 1.) Characteristics of the current Cabin Conversion and Refurbishing market were searched and analyzed. Market segments and applicable modification scenarios were identified.
- 2.) Trends and market forecasts were studied to understand the demand of aircraft, per regions and type of aircraft, and the foreseen growth in air traffic and number of passengers.
- 3.) Driving factors for every scenario, along with its frequency and duration were identified. These three scenario characteristics were used to compute the market evolution on a database of all existing aircraft.

The following segments were forecasted:

- 1.) Upgrade of international cabins
- 2.) Upgrade of domestic cabins
- 3.) Cabin Conversion for narrow bodies on operating lease
- 4.) Cabin Conversion for wide bodies on operating lease
- 5.) Pax-to-freighter conversion
- 6.) VIP completion

*Airline Cabins* are regularly upgraded or refurbished. Each class classification can be associated with such a scenario. The renewal activities may affect:

- the cabin systems – IFE (In-Flight Entertainment), CIDS (Cabin Intercommunication Data System), in-seat power system, passenger oxygen, general illumination of the cabin, emergency lighting;
- the cabin layout – seating configuration (for passengers and flight attendants), position of monuments (galleys, lavatories), crew rest compartments, stowage room;
- or other cabin interior items – linings and furnishings like PSU (Passenger Service Units), curtains, partitions, ancillary equipment; placards and markings like cabin emergency equipment, floor covering.

**Table 10.2** Driving factors for international, domestic cabins and aircraft on operating lease

	Type of demand	Factors
<b>International Cabins</b>	Upgrade of International Cabins	Allows differentiating between airlines Aircraft orders and deliveries are postponed
	Premium Economy introduction	Enhances airline reputation among travelers in Standard Economy Retains a base of loyal customers
	First Class redesign	Demand from successful people even in economical downturn Demand from passengers upgraded to First Class
	First Class removal	More and more luxury in Business Class for a lower fare Rise of all-business-class airlines
<b>Domestic Cabins</b>	New business seats	Short-haul flights drive the reputation of the airline among long-haul business travelers
	New seats	Reduction of fuel burn and extra seating capacity
<b>All</b>	Aircraft lease	Lower cash outlays Protection against aircraft obsolescence Fleet flexibility (change of capacity, new routes introduction)

Table 10.2 lists some of the driving factors for airline cabin upgrades.

*Freighter Cabins* are completely converted by changing the destination of old passenger aircraft. Popular candidates for the pax-to-freighter conversion are, according to ACMG (Air Cargo Management Group) (**ACMG 2012**), for the narrow-body models, the Boeing 737-300s/-400s and 757-200s. For the medium wide-body category, the A300-600s and 767-200s are the major candidates. In the large capacity segment preferred aircraft are 747-400s and

MD-11s. Only the A300-600F, 747-400F, 747-8 Freighter, 777F, A320P2F and A321P2F are available as new-built production freighters, which means the majority of the additional freighters will be passenger-to-freighter conversions (**Dahl 2003**). It is interesting to note that no civil freighter exists that was designed specifically for this purpose. All civil freighters have been derived from passenger aircraft. Military freighters play only a minor role for civil freight transport. The conversion process typically involves incorporating a large wide cargo door in the fuselage, installing a new reinforced main deck floor and integrating cargo loading systems. The conversion of a passenger aircraft into freighter may occur only one time in the aircraft life. After the age of fifteen to twenty years, aircraft would not receive any more upgrades for passenger service due to their marketability. These aircraft become perfect candidates for freighter conversion (**Feir 2001**).

*VIP Cabins* allow several scenarios:

- VIP High-End Completion – the completion center takes responsibility over the design and certification of the interior furnishing of the new aircraft.
- VIP Cabin refurbishing – refers to aircraft which receive a new outfit while removing an old one; this scenario is valid especially for business jets. Such scenarios involve stripping and replacing of cabinetry veneers, soft coverings of the seats, carpets or the lighting.
- Pax-to-VIP conversion – some VIPs buy a former jetliner to use it as an executive aircraft.

Some of the difficulties encountered by these scenarios are:

- Special materials that have never been installed in the aircraft environment have to pass flammability and certification tests.
- More complex changes in the cabin, such as reconfiguring seating or repositioning lavatories and galleys, involve meeting recertification requirements (see Section 10.7).

Figure 10.4 shows the predicted increase in number of passengers, aircraft fleet and airline traffic. Currently Aircraft Design improvements are made for existing aircraft, in order to allow them to become more efficient (like *A320 NEO* or *B737 Max*). Thus an increase in payload is possible. The consequence of this tendency, is that the fleet can grow slower (by only 3.2 % each year), although RPK (Revenue Passenger Kilometers) will grow faster (5.0 %).

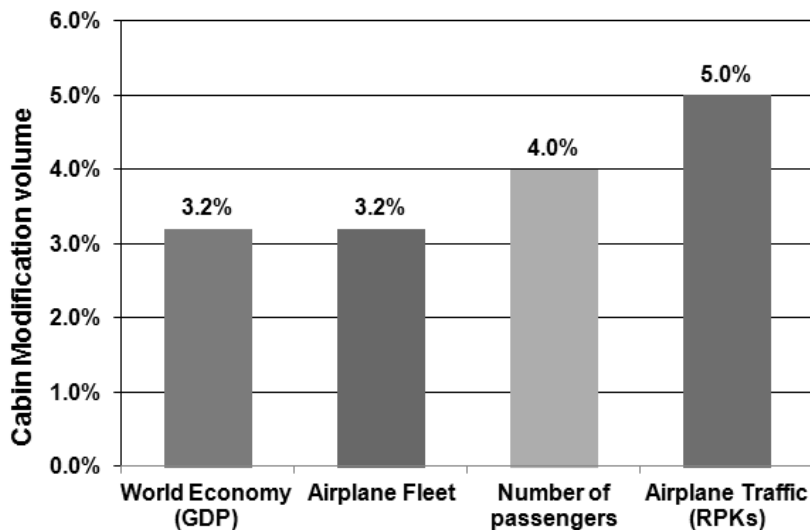

**Fig. 10.4** Passenger key growth rates (Boeing 2009)

The following hypotheses were considered for performing the forecast:

- Normal, utility, aerobatic and commuter (i.e. CS-23) airplanes are not considered, as not enough elements could be found about cabin conversions for these small airplanes. This demand certainly does not affect the whole market of cabin modifications. The error coming along when estimating the cabin design/redesign volume is therefore considered negligible.
- Future aircraft (i.e. the world fleet forecast) which will be operated within the next 20 years and which will modify the future world fleet are not specifically identified, as the fleet forecast is already included in the database under aircraft orders. This will lead to a negligible error as airlines usually plan their fleet at least for the next twenty years.
- A forecast is computed for the next 20 years i.e. all cabin conversions which will be undertaken before 01/07/2029 are counted.
- For each aircraft, the modification scenario is identified; it contains the specific time between two modification programs undertaken by the operator.
- For each aircraft, the number of modifications is obtained by the computation of the specific time between two modification programs and the duration of a refurbishing program.
- For each aircraft, the first modification calculated will occur after the 01/07/2009.
- For each aircraft, the last modification that will be calculated will occur either before the 01/07/2029 or before the end of the aircraft useful life.

Appendix D explains the detailed method applied to produce the forecast.

The results show that the most profitable market segment is the VIP segment. VIP conversions are complex design tasks, but also bring much revenue. This segment is also less sensitive to economic crises.

Figure 10.5 shows the world's future demand in aircraft cabin modifications. The world distribution for each scenario is showed in Figures 10.6 to 10.9.

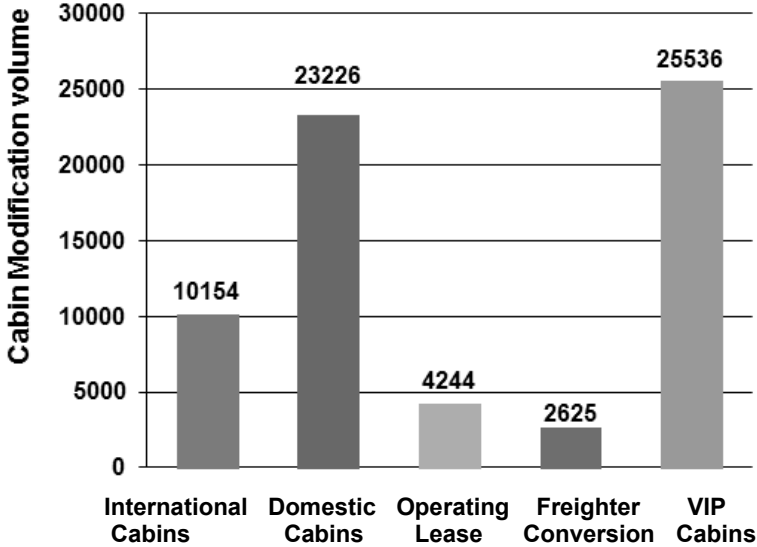

Fig. 10.5 Cabin modification world volume 2009-2029

**Demand for Upgrades of International Cabins**

A large part of the 10100 forecasted wide-body cabin redesigns come from Asia-Pacific area (29 %). Together with China and Middle East, more than 55 % (6000 cabin retrofits) of the demand will be concentrated in a single world continent. Therefore, the Asia-Pacific market will have an important influence on this segment (see Figure 10.6).

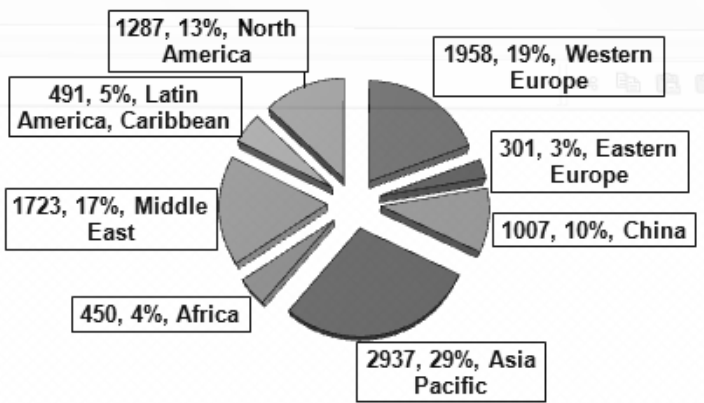

Fig. 10.6 International Cabins: Cabin Retrofit World Distribution 2009-2029

In following positions come Western Europe and North America with respectively 19 % and 13 % of the market share. These results were expected due to the relative small part of the wide-body deliveries in these two regions. Moreover, as it has already been shown, the redesign of wide-body cabins is a tool for differentiation between airlines.



That means, even if aircraft deliveries and orders could be postponed due to possible economical downturns, such as today, airlines will continue to redesign their cabins in order to attract customers at minimal expenses (compared to the purchase of a brand new aircraft). Therefore, the demand for the redesign of international cabins will continue to grow.

Although premium cabins are considered by airlines as very large profit centers, some specialists believe the margins will start to erode as retrofit and innovation costs go up and fares go down from competition. As a result, it will be more difficult to recoup their investment. These specialists believe too that innovation on premium cabins has a limit as customers may not be able to afford it every time they travel (Arnoult 2007).

**Demand for Upgrades of Domestic Cabins**

The North American market will drive the global demand of 23200 domestic cabin retrofits along with the Western European market (respectively 28 % and 23 % of the market share). This is due to the high number of existing narrow-bodies in these regions. However, Asian markets (China, Middle East, Asia-Pacific) are still strong and approximately 60 % of new narrow-bodies will be delivered in these regions (Figure 10.7).

The world demand for cabin redesign of narrow-bodies appears to be a lot stronger than the demand for international cabin redesign. It has to be reminded that the price of such a retrofit is a lot higher than the domestic cabin retrofit price, and this is due to the expenses required by the innovation in premium cabins.

Although comfort and amenities on short-haul flights also drive the airlines reputation, most of them do not currently put the emphasis on it and focus on wide-bodies.

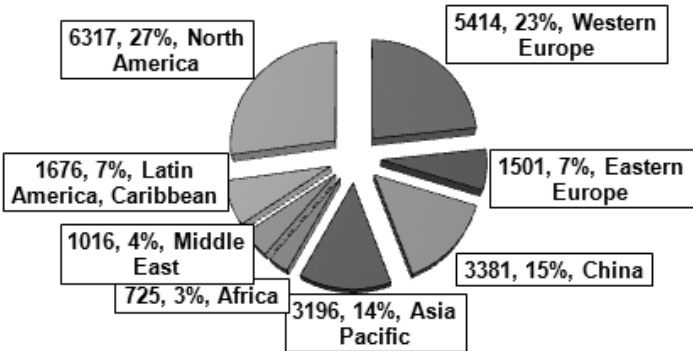
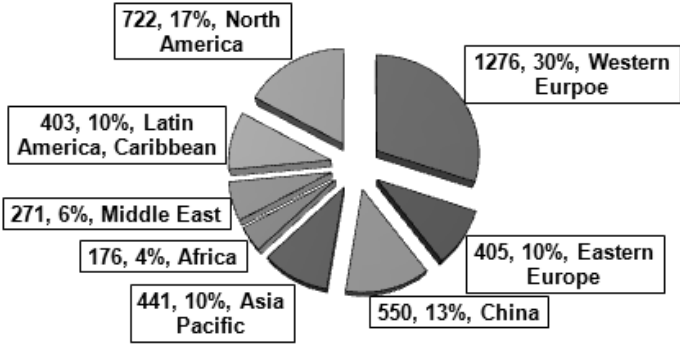

**Fig. 10.7** Domestic Cabins: Cabin Retrofit World Distribution 2009-2029

The real advantage for the domestic cabin redesign is the reduction of fuel burn (through weight reductions) or the increase of seating capacity. However, North American and Western European markets have to be investigated if this segment is suddenly growing because of a future trend.

**Demand for Cabin Upgrades of Aircraft on Operating Lease**

The chart below (Figure 10.8) shows that most of the 4200 cabin conversions of leased aircraft will be undertaken in Europe and in North America with respectively 41 % and 17 % of the market share. This world distribution of the demand is certainly due to the great proportion of Low Cost Carriers (LCC) in Europe and in North America, which operate a great percentage of the leased aircraft. However, the Asian market follows the trend of the market share (China, 13 %, Asia Pacific, 10 % and Middle East, 6 %).



**Fig. 10.8** Aircraft on Operating Lease: Cabin Retrofit World Distribution 2009-2029

It is to be remembered that the leasing of aircraft allows carriers to be more flexible towards market expectations: they can preserve their cash in time of economical downturn; they can meet the market change by quickly remodeling their fleet and they can always offer the passengers new aircraft. For these reasons, the market of aircraft leasing is expected to grow as more and more full service carriers (along with LCC) decide on aircraft leasing, due to the above mentioned advantages.

Because such operators deal with short-term lease contracts, cabin retrofits occur in relative short cycles. As a result, the leasing of aircraft generates an additional strong demand for cabin redesigns for narrow-bodies, as well as wide-bodies.

**Demand for Freighter Conversions**

A strong demand for freighter conversions comes from North America with 55 % of the market share. The second position is shared by Western Europe and Asia-Pacific. This is probably due to the high number of freighters operated in North America.

As already mentioned, a pax-to-freighter conversion is an economical alternative to the purchase of a new aircraft. Moreover, it allows a carrier to keep in service a former airliner, which is no longer suitable for passenger use. This scenario generates, as well, a strong demand for cabin conversions (Figure 10.9).

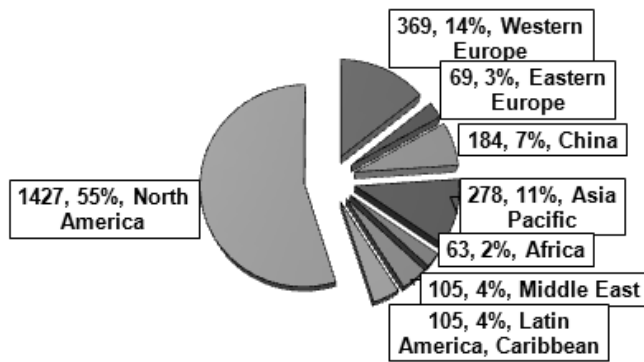

**Fig. 10.9** Pax-to-Freighters Conversion: World Distribution 2009-2029

### **Demand for VIP Completion**

Among the 25500 VIP modifications that are forecasted for the next twenty years, specialists currently see strong interest from India, Russia, the Middle East, as well as China. Traditionally, most of the VIP conversion business has been generated by the Middle East. Specialists think there is enough potential for further growth of the market in this area. It seems that individuals from Russia can afford to ask for bathrooms, dining areas, bedrooms, libraries, children rooms. Russia could dominate the sector within five years, exceeding even the Middle East in its demand. However, the recent crisis has put many of the demands on hold (**Parker 2008**).

Growth is also coming from the South American market, especially in Brazil, and mainly in the business jet segment (**Parker 2008**).

India's fast-growing economy is increasing demand, where a lot of interest in the ACJ and BBJ for both VIP and corporate transport is foreseen (**Parker 2008**).

The very high price of a VIP conversion transforms this market segment into the most profitable, therefore most important scenario of the market. The AeroStrategy estimates that more than  $3.3 \cdot 10^9$  US\$ were spent in 2007 on completing green VIP aircraft and upgrading in-service large executive airplanes. AeroStrategy forecasts that those expenditures could grow to more than  $3.8 \cdot 10^9$  US\$ annually by 2015. Typically, VIP aircraft buyers spend up to  $100 \cdot 10^6$  US\$ for a top-of-the-range completion (**Searles 2008**).

## 10.7 Certification of Aircraft Cabins

In aviation, the safety of the crew and passengers is quantified through the term *airworthiness*. It was mentioned that one of the difficulties in conducting any change to an original design is ensuring its airworthiness.

If it is shown that the aircraft complies with the applicable standards, a *certificate of airworthiness* is issued for each aircraft individually, demonstrating that the required level of safety is fulfilled. Responsible for providing standards for the aviation safety and environmental protection are certification authorities. Certification authorities are also responsible for approving any design, manufacture or maintenance of airplanes or components, as well as for monitoring the implementation of the safety rules. Certification authorities are:

- International Civil Aviation Organization (ICAO)
- Civil Aviation Authorities
- Joint Aviation Authorities (JAA)
- European Aviation Safety Agency (EASA)<sup>1</sup>
- Federal Aviation Administration (FAA)

Any organization that undertakes design work needs to apply for a *Design Organization Approval (DOA)*. Every product designed by a Design Organization holds a *Type Certificate (TC)*, where all the specifications of the product are mentioned. The respective Design Organization is approved by EASA and the Type Certificate is also issued by the Agency. This Type Certificate shows that the Design Organization has proven compliance of the *Type Design* with all applicable requirements (21A.14, **Part 21**).

In the case of Cabin Conversions, one is not talking about designing products, but designing *changes* to products. There are either *minor* or *major* changes to the Type Design. Minor changes are to be classified and approved either by the Agency or the Design Organization (further referred to as DO), under a procedure agreed with EASA (EC 1702/2003, subpart D, 21A.95, **Part 21**). Major changes can be classified by the TC holder but can be performed only under the surveillance of the authority. Design Organizations, *other than the TC holder*, need a *Supplemental Type Certificate (STC)* and the approval from the TC holder to perform the changes (see Subpart E from EC 1702/2003, **Part 21**).

To summarize, Cabin Conversion certifications are possible under the following categories:

- Change of Type Certificate
- Supplemental Type Certificate - STC
- Repair approval

---

<sup>1</sup> Further on, the requirements coming from EASA will be discussed.

Optimization of Cabin Conversion Design Processes is required by EASA (**Part 21**). This is reflected in the criteria for the DO approval, which will be further shortly presented.

The document in which these requirements are stated is Annex Part 21, Subpart J, to (EC) No. 1702/2003 (**Part 21**). This document sets the requirements that need to be fulfilled by any organization wanting to develop design work for aeronautical products. Requirements from Subpart J interfere with requirements from other sub-parts.

The Acceptable Means of Compliance and Guidance Material illustrate the means by which the requirements stated in the rule can be achieved. Once the compliance is demonstrated, the applicant receives a Type Certificate or, as it is the case, a Restricted or a Supplemental Type Certificate (**AMC 21**).

Cabin Conversion designs are, as mentioned before, changes to the Type Design. An applicant for a change to the Type Design of a product needs to submit an application which has to include the description of the change, as well as the identification of (**Part 21**, article 21A.93):

- parts of the Type Design and manuals affected by the change,
- certification requirements and environmental protection requirements,
- necessary re-investigation in order to show compliance.

The EASA certification specifications – CS 25 and CS 23 – provide the requirements for certifying cabin related designs. Additional certification requirements in the field of Cabin Conversions come from operation (**JAR OPS**).

To set up a Design Organization in the form required by EASA to issue the approval, several requirements are to be fulfilled:

- *A Scope of Approval* needs to be clearly defined: For cabin-related activities the technical fields implied in the definition of the scope are:
  - Installation of Avionics and Equipment
  - Environmental Systems
  - Electrical Systems
  - Cabin Interior
  - Galleys or other interior equipment
- *A specialized personnel* covering key functions, depending on the scope of work; the absolute minimum for a very limited scope could be defined for 5 persons, as such:
  - Head of the DO
  - Head of the Office of Airworthiness (OoA)
  - Compliance Verification Engineer (CVE)
  - Design Engineer
  - Quality Management Engineer

- A *Monitoring System* for preventing undetectable errors and failures, which may not be observed by the Agency.
- A *Design Assurance System*, that includes the independent monitoring of compliance.
- A *Design Organization Manual* that describes the organization, the relevant procedures and the products or changes to products to be designed.

Through the DOA itself the Agency is looking to develop among the design companies a safer and more complex self-control function. The purpose is to discharge the responsibility of certifying the product on the engineering and certification team of the DO, while EASA is supervising carefully the actions. The technical processes inside the organization, together with the tools, become of major importance.

The implementation of the EASA standards for creating a Design Organization can follow this sequence (Figure 10.10) (**Nagalingam 2002**):

- Preparation
- Implementation
- Evaluation
- Learning

The *Preparation Phase* includes:

- Understanding the EASA requirements for DOA
- Identifying the purpose of DOA
- Identifying the objectives for getting the DOA
- Identifying and evaluating the consequences of receiving the approval
- Identifying the consequences of not having a DOA
- Identifying the most important points of the integration of the new organization within the company
- Assigning a responsible person / team capable of evaluating the DO implementation process
- Determining the functions and responsibilities of the personnel involved in getting the DOA
- Identifying the activities, already existing in the company, which can be part of DO
- Defining clear goals and proper management strategy for implementing DO concept
- Identifying the key performance indicators
- Identifying the type of necessary documents inside the DO, by respecting EASA indications
- Identifying simplest and clearest way to create the documents, by considering aspects like: form, annotations, signatories
- Preparing the *implementation plan*, based on a schedule
- Preparing the implementation processes
- Evaluating the costs and the revenues

Part of the *implementation plan* prepared during this phase should, first of all, be all the aspects quoted in the Part 21 and the other relevant parts referred to in this chapter. Secondly, other sources, such as technical documentation standards or quality management standards, can be taken into account. This means that the implementation plan must include prescriptions regarding:

- The setting up of the Design Assurance System
- The functions and responsibilities of the personnel inside the DO
- The creation of the DOM
- The way the Monitoring System will function
- The tools necessary for the flawless functioning of the DO
- The showing of compliance
- The Quality Management Strategy

The Preparation Phase is of major importance and implies the contact with the EASA.

The *Implementation Phase* includes:

- Implementing the plan elaborated during the preparation phase
- Collecting data to supply it to the evaluation phase
- Supervising the plan integration
- Creating a knowledge base

The *Evaluation Phase* includes:

- Evaluating the functioning of the components of the DO
- Reviewing of the processes, if it's necessary
- Standardizing the processes
- Evaluating and standardizing the document flow
- Establishing monitoring measures
- Analyzing and evaluating the tools

The *Learning Phase* includes:

- Assessing the results from the evaluation phase
- Reflecting on the possible improvements and implementing them
- Standardizing all the procedures inside DO
- Standardizing the document flow, regarding annotations, form and signatories
- Standardizing the communication system within DO and with EASA
- Standardizing the data storage

These phases were established with the help of the methodology for implementing the concurrent engineering concept developed at the Center for Advanced Manufacturing (CAMR) of the University of South Australia. The concurrent engineering concept will also be presented in the following chapters.

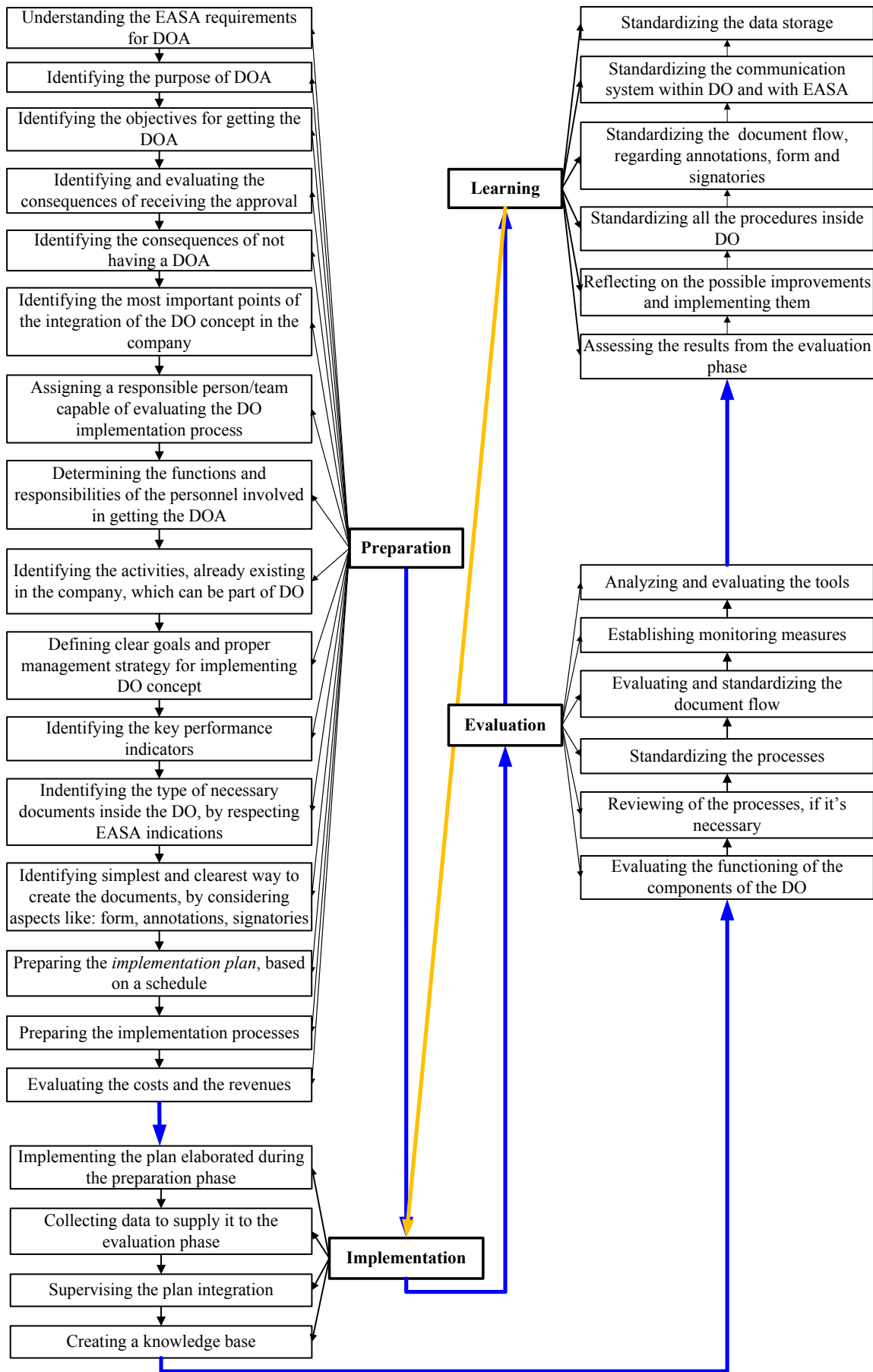

**Fig. 10.10** Preparation for DOA implementation – Process Chain representation





# 11 Optimization of the Process Chain for Cabin Conversions

Section 10 showed the various aspects for which Cabin Design and Cabin Conversion are two connected engineering tasks that play an important role in industry, in economy and in our lives. It is essential to increase efficiency starting from bottom – and this is one of the central motives that drove the topic of optimization of this work.

This is the reason why this section proposes a scientific approach to process chain optimization. The study case is performed on the Process Chain for Aircraft Cabin Conversions (Appendix C). This process chain was briefly described in Section 10.4.

## 11.1 Process Chain Representation Models

In order to establish and improve processes, to document them (e.g. for compliance reasons), or to define roles and responsibilities as well as to understand the relation between them, the process planning and modeling of activities have a vital importance. Models allow processes to be controlled and analyzed with the purpose of improving them. There are numerous approaches available to support Process Management, each depicting various aspects.

### 11.1.1 Flow Charts

Typically, processes are modeled as flow charts that produce large process maps to describe how a company is progressing from a customer request to the delivery. They are focusing on information flows from one activity to another. Most of them capture the interactions between tasks, documents, events, roles or resources, and time (see Table 11.1). Some of these methods, applicable also in aerospace industry, are (**König 2008**):

- *Structured Analysis and Design Technique (SADT)* - it is part of a series of structured methods, that represent a collection of analysis, design, and programming techniques. Basically it describes systems as hierarchy of functions and can be used as a functional analysis tool; it uses successive levels of details: either through a top-down decomposition approach or by means of activity models and data models diagrams (**Nam 2001**);

- *Integrated Definition (IDEF)* - is a family of modeling languages covering function modeling, information modeling, knowledge acquisition or object-oriented analysis and design; IDEF0 is a language building on SADT and IDEF1 addresses information models.

There are up to 14 languages (developed through the US Air Force funding), each having a specific purpose; IDEF 3 refers to Process Description Capture (**Mayer 1995**);

- *UML-Activity diagrams* - includes a set of graphical notations techniques to create abstract models of specific systems; it uses entity relationship diagrams and work flow modeling (**Noran 2000**);

- *Business Process Modeling Notation (BPMN)* - provides a graphical notation for specifying business processes in a Business Process Diagram (BPD); it is similar to UML; it uses elements like flow objects, connecting objects, swim-lanes and artifacts (**Simpson 2005**);

- *XML Process Definition Language (XPDL)* - is a format standardized by the Workflow Management Coalition (WfMC) to interchange Business Process definitions between different workflow products; it has been designed specifically to store all aspects of a BPMN diagrams (**Van der Aalst 2003**);

- *Process Module Methodology (PMM)* - methodology for the flexible planning, monitoring and controlling of highly complex dynamic development processes; The fundamental approach adopted here is to specify the process steps but not the order in which they should occur, allowing the process to be amended easily when they run (**Bichlmaier 1999**);

- *Event-driven Process Chains (EPC)*, either event-driven or object-oriented (oEPK) - are used to analyze processes for the purpose of an ERP (Enterprise Resource Planning) implementation, which is a computer software system used to manage and coordinate resources, information and functions of a company (**Van der Aalst 2003**);

- *PERT (Program Evaluation and Review Technique)* - is a method to analyze the involved tasks in completing a given project; it identifies the minimum time needed to complete the total project; it uses key terms like: critical path, lead time, optimistic time or expected time (**Chanas 2001**);

- *Critical Path Method (CPM)* - it determines critical activities using the same approach as PERT: by representing the duration along with the processes and relations between them and by calculating meaningful durations like for instance the latest when an activity can start without affecting the project (**Chanas 2001**);

- *Work Breakdown Structure (WBS)* - illustrates all the activities being part of a project, by breaking them down up to achieving the deliverables; it is a highly used method also in the aerospace sector: Airbus has set the WBS usage as requirement for their subcontractors. The WBS is detailed enough and can be used as management control tool (**AP 1500**). Along with the WBS, the OBS (Organization Breakdown Structure, for personnel and responsibilities)

and the RBS (Resources Breakdown Structure, for identifying resources associated to the work package) can be used;

- *GANTT* – is a bar chart illustrating a project schedule, by representing start and finish dates; it is highly used in every domain of activity.

Table 11.1 compares some of the methodologies briefly presented above. These methodologies were studied having in mind the type of processes involved in Cabin Conversion. However, flow charts are not the only available method (see next paragraph).

**Table 11.1** Comparison of common process modeling methodologies (König 2008)

Process Modeling Methodologies / Constructs	Task	Document		Event		Role /Resource				Time												
	Function	Operation	Activity	Transition	Data Object	Attribute	Input	Output	Event	Message	Object	State	Places	Organizational Unit	Resource	Attribute	Methods & Tools	Resources	Milestone	Lead Time	Start / End Time	
UML	X	X	X	X	X	X	X	X	X	X	X	X	X	X	X	X	X	X	X	X	X	X
EPC	X				X				X					X	X					X		
oEPK		X				X				X	X			X		X						
IDEF			X				X	X				X										
Petri-Net			X	X									X									
PMM			X				X	X									X	X	X			
PERT			X																		X	X

### 11.1.2 Matrix Representation

Another possible way of representation for system analysis and management is the use of matrices. Recently developed, was the Design Structure Matrix (DSM) and its derivatives: Domain Mapping Matrix (DMM) – allowing mapping between two different views on a system and Multiple Domain Matrix (MDM) – combining a DSM and a DMM into a complete system representation.

The DSM is a square matrix that shows relationships between elements in a system (DSM 2009). The Design Organization, as EASA requires, needs to function as a system which in the end needs to prove to the authorities that it can deliver a certified design or modification to a design. The optimal functioning of the DO as a system is determined by



The parallel configuration shows that the tasks are independent on each other (example: between tasks A and K in Figure 11.2 there is no information flow). The sequential configuration shows the information flow is unidirectional between two tasks (example: task C receives information from task B). In the case of coupled tasks the information flow is dual, coming from both start and end task (example: task H receives information from task E, task D receives information from task E and task D gives back information to task H). In contrast to Figure 11.1, here the arrow is set downwards, which means the feed-forward information flow is visible in the lower half of the matrix. The user can set the direction as he likes.

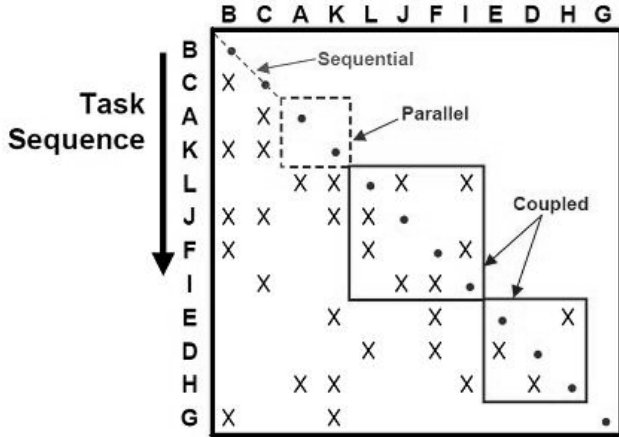

Fig. 11.2 Configuration possibilities of the interrelations between tasks (Eppinger 2002)

### 11.1.3 Concurrent Engineering Concept

The Concurrent Engineering concept was found to be suitable for optimizing design cycles, especially in the preliminary phases. Optimizing a process chain of a complex system, like a Completion Center, means looking to minimize time and errors. Using a concurrent engineering approach, for example by developing parallel design tasks, was found to be helpful with this respect.

In this section, the concept is briefly presented, as a helpful methodology to be considered when implementing design processes inside Completion Centers.

Concurrent Engineering takes into account all the elements of the life cycle of the product at an early stage and in the same time (or concurrently). Therefore, processes like establishing requirements, creating and running computational models or testing the product are optimized through the iterative design approach (Zhong 2008).

Some of the driving characteristics of this concept are:

- Parallelization of the design tasks
- Early design reviews

- Software tools, allowing adaptation of the design in an early phase
- Good communication among the engineering team

To achieve the results which come along with the implementation of Concurrent Engineering, it is necessary to create a specific design environment in the form of a facility allowing efficient data interchange and communication between the engineers responsible for different tasks. Such a facility should be modeled through at least the use of (DLR 2009, ESA 2009):

- An array of design stations equipped with Hardware and Software tools suitable for each discipline
- Video conferencing equipment
- Access to Knowledge databases

The use of this concept within a Completion Centre can be done by integrating the perspectives of all design phases in the early phases of the concept. In cabin refurbishing it is important to consider the certification requirements already in the preliminary discussions. The consequence is reducing later modifications and delays in the end phases of the Cabin Design.

#### *Why Concurrent Engineering and DSM?*

Concurrent Engineering can also be described through the DSM model of representation, as it is shown in Schlick 2008. This is the reason why the decision is taken to research more in depth the matrix way of process representation.

Another argument is that the method has been already applied by one of the most important aircraft manufacturers, Airbus, in an attempt to implement the Multidisciplinary Design Optimization in analyzing complex new projects, like the A3XX (the present A380). A way of dealing with such challenges is by breaking the large task of system optimization into smaller concurrently executed, and yet, coupled tasks, identified with engineering disciplines or subsystems (Sobieski 1989). Cabin Design and Conversion, is similar with Aircraft Design, in which the Multidisciplinary Design Optimization has been applied. The only difference is the scale: even if Cabin Design is only a part of Aircraft Design, there are a lot of interfering systems which need to be integrated. Therefore a representation allowing both a global and a detailed view, an hierarchical and a non-hierarchical view between tasks is to be considered also in the process representation of this study.

## 11.2 Dependency and Structure Modeling Optimization Methodology

The Dependency and Structure Modeling Methodology started in the 1980's from the idea of using graph theory in order to represent the sequence of design tasks of a complex engineering project as a network of interactions (Steward 1991). This network is represented by a quadratic matrix with identical row and column headings, called Design Structure Matrix (DSM), containing relations and interactions in their nodes (see Figure 11.3).

### 11.2.1 Types of DSMs and Their Application

There are several types of domains as well as relations which can be expressed through a DSM. This diversity leads to a DSM classification as shown in Figure 11.4.

*Static DSMs* do not depend on time, therefore the elements exist simultaneously. Such elements are components of a system, in which case the DSM is component-based, or members of a team, in which case the DSM is people-based. A static DSM analysis would provide results with respect to product decomposition or information flow among members of an organization (Browning 2001, Bartolomei 2009).

*Time-based DSMs* consist of time dependent nodes. The elements of the matrix can be represented by activities. In this case the DSM analysis provides their optimal sequencing. The nodes (or elements) can also be represented by parameters related to system activities. An analysis of such a DSM would help identifying activities that influence the design parameters (Bartolomei 2009).

		1	2	3	4	5	6	7
Offer	1	1						
Concept	2	1	2	1				
Definition	3	1	1	3	1			
Design	4	1	1	1	4		1	
Adjustment	5	1	1	1	1	5	1	1
Certification	6	1	1	1	1		6	
Handover	7	1	1	1	1		1	7

Fig. 11.3 Example of DSM showing the relations between the main phases of the process chain for cabin conversion



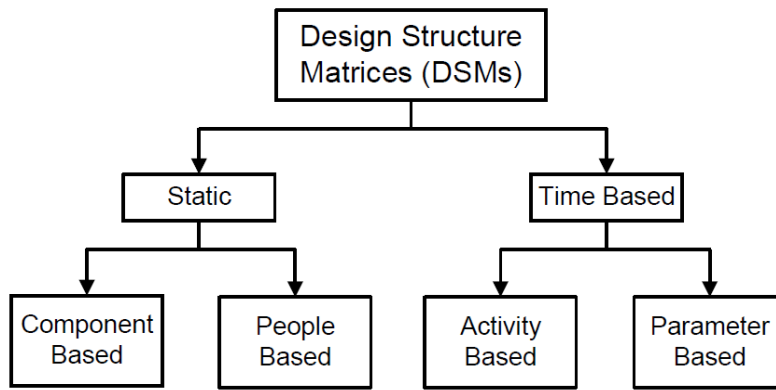

**Fig. 11.4** Classification of DSM (based on **Browning 2001**)

The way to read a DSM can be shown based on Figure 11.3:

- The input information can be read along the rows – i.e. process 4 (design phase) receives information from processes 1, 2 and 3 (offer, concept and definition).
- The output information can be read along the columns – i.e. process 4 (design phase) gives information to process 3 (definition).
- The information exchange is marked through the logical operator true / 1.

The order can be inverted if the user decides to change this convention. In this case one can read the input information on the column and vice-versa. Usually this convention is indicated by an arrow mark above the matrix (as shown on Figure 11.3).

The logical operators only show the coupling between the nodes. It is possible to replace them by numbers in order to show the degree of dependency between the elements (**DSM 2009**):

- 1 – high dependency
- 2 – medium dependency
- 3 – low dependency

**Browning 2001** and **Pimmler 1994** use positive and negative numbers, called coupling coefficients, to express the ranking of the interactions (see Table 11.2). Negative numbers need to be carefully implemented into the tools which optimize DSMs, as they may not function properly.

The *key factor* in using the DSM methodology is the *correct input of the logical operators*, respectively coupling coefficients into the matrix. Researchers of this topic (**Browning 2001**, **Pimmler 1994**, **Danilovic 2007**, **Bartolomei 2008**) agree on the following preparing steps:

1. Clear definition of system boundary and functionality
2. Identification of system components

Proper fulfillment of Steps 1 and 2 make step 3 possible, which needs additional information from the members of the organizational staff and engineers:

3. Identification of interfaces between components.

**Table 11.2** Interaction quantification scheme (based on **Pimmler 1994**)

Information	Weight	Information exchange is...
Required:	+ 2	...necessary for functionality
Desired:	+ 1	...beneficial but not absolutely necessary for functionality
Indifferent:	0	...does not affect functionality
Undesired:	- 1	...causes negative effects but does not prevent functionality
Detrimental:	- 2	...must be prevented to achieve functionality

The engineers need to be questioned with respect to the type and frequency of interactions between the components, in order to estimate the right position and intensity of the coupling coefficient. The additional sub-steps are required:

- 3.1 Preparation of questionnaires
- 3.2 Gathering and analyzing the results.
- 3.3 Implementing the results into the matrix

A Design Structure Matrix can only be used to analyze interactions between elements of the same type. In order to see for instance which team is suitable for which activity, one would need to combine a people-based DSM with an activity-based DSM and analyze the interactions as a whole. This analysis is possible in the frame of a Domain Mapping Matrix (DMM). A DMM is a rectangular matrix which examines interactions between two domains.

The literature about DMMs indicates that there are at least 5 major domains which interact in product development (**Danilovic 2007**):

1. Goals
2. Product
3. Process
4. Organization
5. Tools

The interactions inside the five domains listed above are represented in DSMs. The interactions between the domains are illustrated with DMMs (see Figure 11.5).

DMM analysis methods are relatively new, thus the literature is limited. The advantage of expanding the analysis beyond single domain information gives however enough reason to consider the DMM approach. To summarize, the main characteristics of both DSM and DMM are listed in Table 11.3.

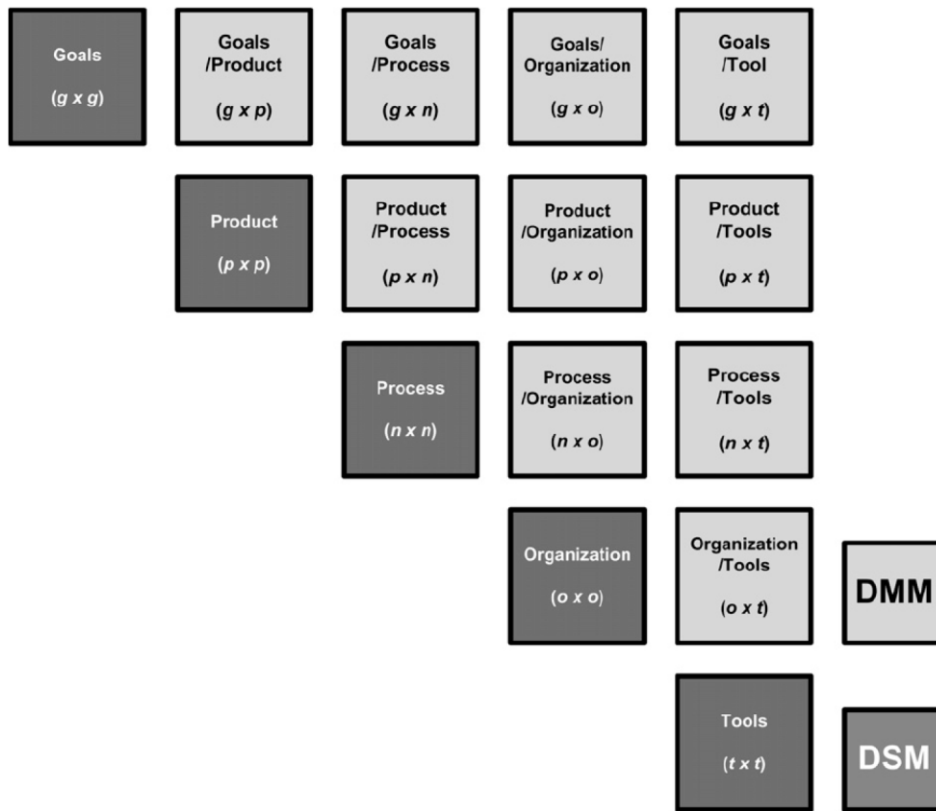

**Fig. 11.5** DSMs and DMMs for the five project domains (Danilovic 2007)

**Table 11.3** Main characteristics of DSMs and DMMs (based on information gathered from References Browning 2001, Danilovic 2007, Bartolomei 2008)

Criteria	DSM	DMM
Representation	$n \times n$ matrix	$n \times m$ matrix
Dimension	Single domain	Dual domain
Focus of Analysis	Tasks Activities Parameters Components People Information flow Deliverable flow	Components / Organization Project / Organizational Structure Functionality / Product Architecture Information flow

## 11.2.2 Optimization Algorithms

Several analysis algorithms are applicable depending on the type of elements represented into the matrices. The aim of the investigation towards the DSM methodology is to apply it for the optimization processes required to perform an Aircraft Cabin Conversion. The interest of this study is, therefore, to highlight and apply those algorithms suitable for activity based components analysis.

A number of 143 processes for completing a Cabin Conversion (while considering a low degree of detail) were identified (see Appendix C). The analysis of a great number of

processes with the DSM method requires the automation of the optimization. Highly detailed DSMs use programmed algorithms and computer aid.

If the purpose is to optimize the sequence of the activities, the suitable algorithm is called *partitioning* or *sequencing*. If the purpose is to assign proper personnel to specific tasks, the suitable algorithm is called *clustering*, as it allows grouping of the highly related elements into clusters (**Eppinger 2002, Danilovic 2007, Bartolomei 2008**).

*Partitioning* aims to reorder the sequence of the elements in order to obtain a lower triangular matrix (according to the convention from Figure 11.3, otherwise the algorithm would deliver an upper triangular matrix). This is achieved by manipulating the rows and columns of the matrix such that the coefficients move closer to the main diagonal and reduce the negative feedback between the elements. The result is a minimized waiting time between activities. The conclusion to be drawn (**Bartolomei 2008**) is that *minimizing feedback eliminates the process iteration and spares time*.

When looking at the matrix in Figure 11.3, it can be observed that coefficients above the diagonal indicate the necessity of a task to wait for the completion of another task which is to be fulfilled in the future.

The problem formalization can be expressed through the following exemplary question for element number 5: Can process number 5 be fulfilled after processes 6 and 7? If yes, then insert 1. Do processes 1, 2, 3, 4 give information to process 5? If yes, then insert 1.

The following observations after analyzing Figure 11.3 can be extracted:

1. The concept phase can suffer modifications after the definition phase.
2. The definition phase can suffer modifications after the design phase.
3. The design is influenced by the certification requirements, and can later suffer modifications accordingly.
4. All phases provide information for the adjustment phase.
5. All phases, besides adjustment and handover give information to certification phase.
6. Handover phase receives information from all other phases, besides adjustment, to which it gives feedback.

Applying the partitioning algorithm to the matrix in Figure 11.3 means reordering the phases in the most economical manner. Due to the fact that the dimensions of the matrix are small, a manual manipulation is possible. The following steps are required (based on **DSM 2009**):

1. Identification of the elements which do not receive information from the others (by looking for empty columns) and moving them to the right.
2. Identification of the elements which do not give information to the others (by looking for empty rows) and moving them to the left.

- If after steps 1 and 2 there are no remaining elements in the DSM, then the matrix is completely partitioned; otherwise, the remaining elements contain information circuits, which can be further optimized.

**DSM 2009** provides a tool, developed at the Technical University München, which can automate the process of partitioning. Figure 11.6 shows the partitioned matrix obtained with this tool from the original matrix shown in Figure 11.3.

		Offer	Concept	Definition	Design	Certification	Handover	Adjustment
		1	2	3	4	6	7	5
Offer	1	1						
Concept	2	1	2	1				
Definition	3	1	1	3	1			
Design	4	1	1	1	4	1		
Certification	6	1	1	1	1	6		
Handover	7	1	1	1	1	1	7	
Adjustment	5	1	1	1	1	1	1	5

**Fig. 11.6** The partitioned matrix obtained from the original matrix shown in Figure 11.3

From the results obtained, the following conclusions can be extracted:

- The adjustment phase was moved at the end of the sequence; it is the last to be fulfilled, once it receives the feedback from all other phases.
- There are still coefficients above the diagonal (market in light blue) but they are required for the proper functioning of the system.
- The light blue indicates that the information exchange is bidirectional, which means the three phases are coupled.

Besides partitioning, another algorithm may be of interest when it comes to setting up a completion center. The *clustering* algorithm will be further illustrated, but its application is beyond the purpose of this paper.

While partitioning is suitable for time-dependent elements, clustering is suitable for time-independent systems, such as product architecture or project organization (**Danilovic 2007**). Clustering focuses on *identifying groups of items*. It is, for example, useful when the elements of the matrix are people, which need to be grouped in teams. When it comes to designing a product, another application of the clustering algorithm is in the *system decomposition* and can help identifying the sub-components suitable for the system modularization. The procedure is similar to partitioning: columns and rows are reordered with the purpose to

underline the elements which are highly interconnected. Interactions between clusters are, in the same time, minimized (**Bartolomei 2008**).

**Table 11.4** Comparison between DSM and DMM (based on **Danilovic 2007**)

Dimensions	DSM		DMM
	Partitioning analysis	Clustering analysis	
Partitioning algorithm	Block diagonalization / Triangularization	Clustering in blocks along the diagonal	Move items into clusters
Result of the analysis	Sequence of items, activities	Cluster of items	Cluster of items
Visualization of dependencies	Feedback and circuits Loop of items Parallel items Sequence of items	Cluster of items Dependencies of clusters	Cluster of items Dependencies of clusters
Key words	Tasks Activities Information flow Deliverables	Parameters Components People Organization Information flow	Components / Organization Project / Organizational Structure Functionality / Product architecture

Partitioning and clustering are algorithms suitable for DSM analysis. When it is required to analyze the interaction between two domains within a DMM, the algorithms need to be adapted. **Danilovic 2007** provides an analysis with respect to applicable algorithms for DMMs. His conclusions are summarized in Table 11.4.

### 11.3 Analysis of the DSM for the Process Chain for Cabin Conversion

In the previous section a DSM analysis was already performed on the *coarse matrix* (illustrated in Figure 11.3) with the purpose to exemplify the functioning of the partitioning algorithms. The following paragraphs will apply the algorithm for the *fine matrix*, which includes all the processes identified and included in Appendix C. Other two types of analyses are as well illustrated: the *eigenstructure analysis* and the *cross impact analysis*.

#### 11.3.1 Partitioning Algorithm

The processes were introduced in the MS Excel tool (**DSM 2009**) and the algorithm was run. By manipulating the rows and columns, a minimal feedback process configuration was obtained. Figure 11.7 illustrates, as far as possible, the partitioned DSM.

This analysis required a long preparation time and the main difficulties consisted of:

- understanding the dependencies between each process,
- inserting them into the matrix,
- having a clear view over the whole complex structure.

After overcoming these difficulties and running the algorithm, the following conclusions were extracted:

- Definition, Design and Certification phases are coupled (light blue); they create an information cycle which needs iteration, and therefore further optimization.
- Other small couplings exist between the teams for engineering, certification and quality assurance.
- A detailed analysis of the matrix and of each of the illustrated dependency allows a better understanding of the results.

### 11.3.2 Eigenstructure Analysis

When aiming to optimize a large number of processes, it helps conducting an analysis which allows the extraction of the most important ones. The eigenstructure analysis for DSMs was developed by Smith and Eppinger in **Smith 1997**. In our case it helps underlining those processes which have a major influence on the system.

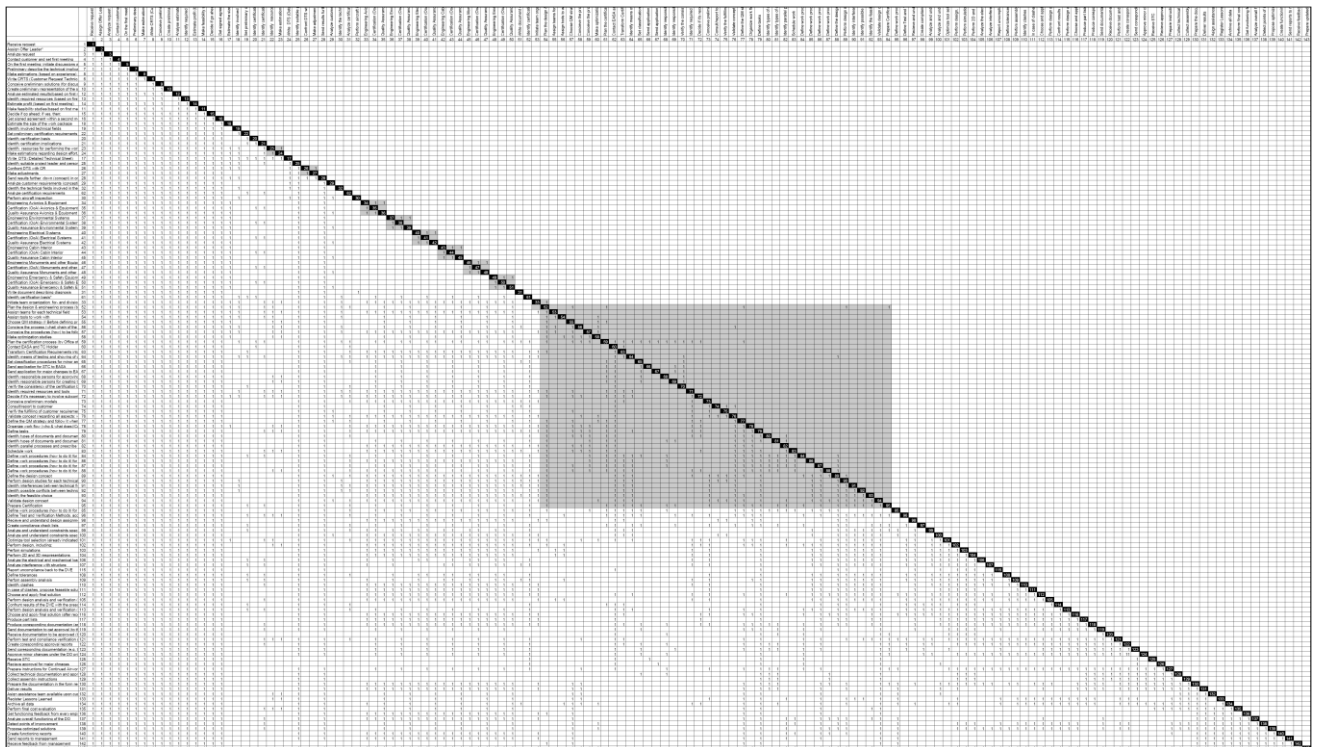
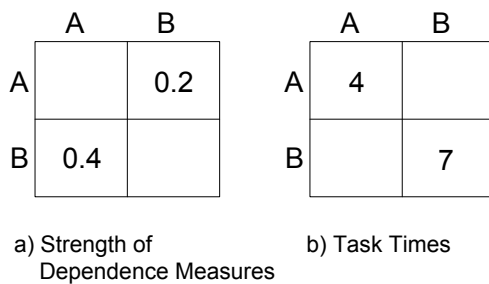

**Fig. 11.7** The partitioned DSM resulted after running the partitioning algorithm on the original DSM

Another interesting analysis is to optimize the duration of the development time (Smith 1997):

- Serial tasks can be evaluated by summing their individual times.
- Parallel tasks can be evaluated by finding the maximum of those task times.

In this case a Work Transformation Matrix (WTM) (Smith 1997) needs to be used. Each iteration causes rework; the amount of rework is quantified through this matrix. The off diagonal elements of WTM represent the strength of dependence between tasks – for our analysis, the rework necessary for each task. The diagonal elements represent the time that it takes to complete each task during the first iteration (see Figure 11.8).



**Fig. 11.8** Work Transformation Matrix (WTM) (Smith 1997)

The eigenstructure analysis of the process chain was performed on the WTM under the consideration that the amount of rework is 100%. In this way the problem became simpler to handle (by inserting 1 instead of proportions of 1) and the results were covered by the largest safety margin possible. The steps for conducting the analysis were:

1. Building the WTM.
2. Calculating the eigenstructure i.e. eigenvalues and eigenvectors of the matrix.
3. Interpreting the magnitude of the eigenvalues.

Results are summarized by Table 11.5.

**Table 11.5** The processes with the largest eigenvalues

Process ID	Process Title	Eigenvalue
50	Organizing team for certification	6.43
51	Organizing team for quality assurance	2.21
52	Planning the Design & Engineering process	2.21
53	Assigning Teams for each technical field	2.31
106	Analyzing electrical and mechanical loads	1.62
113	Performing design analysis and verification	1.62
121	Perform test and compliance verification	1.00

The eigenvalues and eigenvectors determine the nature of the convergence of the design process in a similar way with the aircraft dynamics:

- the eigenvalues give information about the rate of convergence,
- the eigenvectors give information about the shape of the natural motion.



An interesting similarity between the dynamical behavior of a physical system and the behavior of the tasks / processes of an engineering system can be noticed. In both cases *large magnitude positive eigenvalues* give information about the convergence of the system, as it can be interpreted from Table 11.5. Within a Completion Center, it seems that certification (eigenvalue 6.43), along with quality assurance (eigenvalue 2.21) play a key role along with the planning the design and engineering process and the team selection. A second major importance is represented by the tasks grouped under the design analysis and verification. The results are plausible, especially when considering the way EASA developed the DOA requirements. For EASA the self control capability of each Design Organization presents a major importance.

### 11.3.3 Cross Impact Analysis

Another type of analysis which can be performed based on the DSM is the Cross-Impact Analysis. The data is analyzed by means of a Cross Impact Matrix, as illustrated in Figure 11.9. The red numbers represent the strength of the influence exercised by each factor / task over the rest of the factors / tasks. It is assumed for our analysis that the influence is always either 1 or 0. Depending on the convention, the tasks are either passive or active. The aim of the Cross-Impact Analysis is to identify several meaningful influence zones and the processes belonging to them. The values representing the strength of the relations are summarized per row and per column. The results are graphically represented as shown in Figure 11.10. There are five meaningful zones which can be identified:

1. **Zone I: Reactive Processes** – Changes of elements in this area have a strong influence on the system; they give a lot of information to the rest of the components.
2. **Zone II: Dynamic Processes** – Changes of elements in this area have an important influence on the system; the information exchange is strong on both sides.
3. **Zone III: Impulsive Processes** – Elements in this area have a small influence on the system but are strongly influenced by other system changes.
4. **Zone IV: Low Impact Processes** – Elements in this area have a small influence on the system and are poorly influenced by other system changes.
5. **Zone V: Neutral Processes** – Elements in this area find themselves at the intersection with other domains; neutral means safe from unexpected effects.

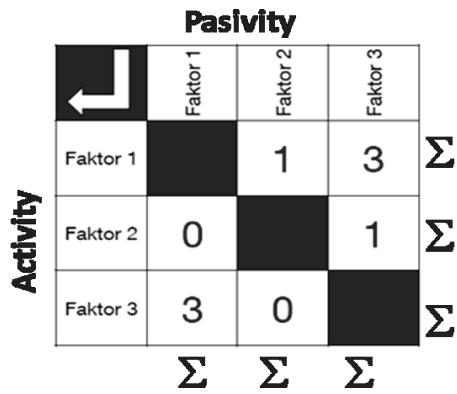

Fig. 11.9 Cross Impact Matrix example (based on Phleps 2009)

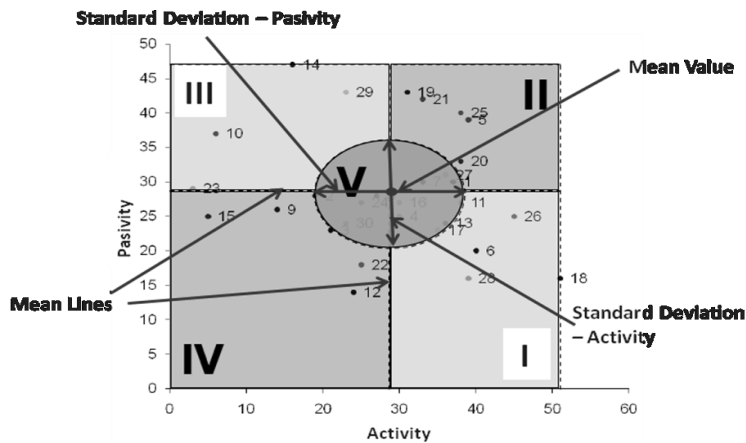

Fig. 11.10 Cross Impact Diagram (based on Phleps 2009)

Based on the DSM, the following results for the parameters describing the diagram were obtained through MS Excel calculation (see Table 11.6):

**Table 11.6** Results for the parameters describing the Cross-Impact diagram

Partitioned DSM	Activity	Pactivity
Sum	5271	5271
Mean Value	36.86	36.86
Standard Deviation	40.067	19.147
Minimum	0	0
Maximum	142	85

Due to the large number of processes the diagram is not easy to interpret. However ‘clouds’ of processes can be identified. The diagram is shown in Figure 11.11 and an overview of the results in Table 11.7.

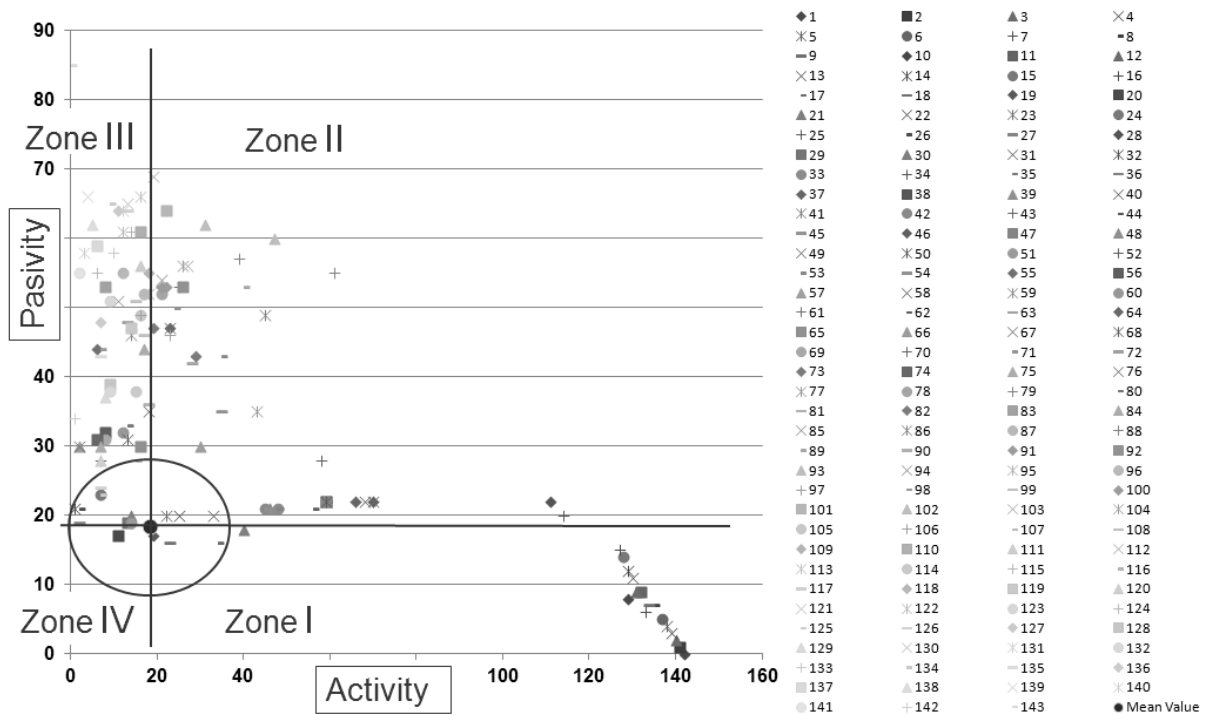

**Fig. 11.11** The Cross-Impact Diagram based on the DSM

*Processes in zone I*, like feasibility studies or getting the signed agreement, strongly influence the rest of the processes: unless the contract is signed and the technical proposal accepted, the rest of the processes are not run anymore.

*Processes in zone II*, like validating the design concept or identifying the certification basis, are very important for the functioning of the system and require a lot of information from the rest of the processes.

*Processes in zone III*, like proposing solutions for an optimized functioning are processes which require a lot of feedback information from the rest of the processes, while their influence may be important in the future, and not for the respective project / iteration.

*Processes in zone IV*, like adjusting a document, once new information is available, have a low impact on the system.

*Processes in zone V*, like estimating the size of the work package and design effort, are in the neutral zone. They are important for the system, but the results are rather expected.

**Table 11.7** Selected processes for each zone of influence

---

Zone I	(2) Assign Offer Leader (126) Receive approval for major changes (9) Conceive preliminary solutions for discussing it with the customer (based on the first meeting) (10) Create preliminary representation of the solutions found (12) Identify required resources (based on the first meeting) (14) Make feasibility studies (16) Get signed agreement
Zone II	(94) Validate design concept (87) Define work procedures for quality assurance (79) Define tasks (definition phase) (93) Identify feasible choice (when it comes to interferences) (design phase) (73) Conceive preliminary models (concept phase) (61) Identify certification basis (concept phase) (54) Plan the design and engineering process
Zone III	(137) Analyze overall functioning of the DO (133) Register Lessons Learned (75) Verify the fulfillment of the customer request (139) Propose optimized solutions (for the functioning of DO) (143) Prepare updated procedures for the functioning of the DO (138) Detect points of improvement (of the DO) (119) Send documentation to EASA (to get approval)
Zone IV	(27) Make adjustments of the DTS after confronting it with CR
Zone V	(17) Write DTS (18) Estimate the size of the work package (24) Make estimations regarding design effort (30) Perform aircraft inspection (31) Write document describing diagnosis (32) Identify the technical fields involved in the design process (concept phase) (62) Analyze certification requirements (concept phase)

---



# 12 Conclusions and Summary of Contributions

## 12.1 Overview

This work substantiated the research on initial stage Aircraft Design and Optimization.

An extensive study on methods and equations used in Aircraft Preliminary Design was performed, and wherever inconsistencies were found, or the degree of accuracy was not sufficient, own methods or method improvements were presented. Section 2 described the contributions to Aircraft Preliminary Sizing and Conceptual Design and Section 3 focused on Cabin Preliminary Design. The aircraft cabin is vital for the overall aircraft efficiency, first through its economical importance, and second, through its impact on aircraft performance. Both these aspects were accounted for when performing aircraft preliminary design optimization. Combining aircraft and cabin comfort parameters in an optimization loop is a new approach to Aircraft Preliminary Design.

The resulting methodology was applied in creating a tool, called *OPerA – Optimization in Preliminary Aircraft Design* that was able to respond to all questions rose in the problem statement of this research. The consistency of the correlations included in the tool was tested on the basis of the Airbus A320-200 reference aircraft. Section 7 described the tool and the tool suite it is part of.

Section 5 showed arguments for selecting the right optimization technique, for the resulting compendium of equations. Selected were Evolutionary Algorithms for their capacity of finding global optima independently from the form of the objective function. Initial tests conducted with a commercial optimization platform, called Optimus® aided the algorithm selection process. The Differential Evolution technique was found most suitable and was programmed in Visual Basic for Applications.

Section 6 presented the implementation of Differential Evolution into OPerA. Initial tests with the standard version of the algorithm and default values for the control parameters showed a mediocre convergence. A convergence improvement and a well adapted choice of algorithm control parameters to the characteristics of the objective function produced results slightly better than the commercial tool with its default settings. The duration of the VBA experiment runs was similar to the duration required by Optimus®, but the number of iterations required was double. Compared to the VBA code, Optimus® offers plotting alternatives up to 4 variables, through bubble plots. If licenses are available, both optimization procedures may be adopted in OPerA.

Section 8 described the objective functions, and presented a new approach to building an original one, composed by Added Values and Direct Operating Costs. With the aid of expert

inquiries and mathematical analysis, questionnaires were evaluated and weights were attributed for every cabin parameter able to bring additional revenue to an airline.

Section 9 presented selected optimization results for four study cases. Besides the optimization of the standard configuration based on the A320-200 aircraft, technology insertions were tested: high by-pass ratio engines, braced wing configuration, natural laminar flow, winglets and wing span limitation increase. These are promising innovations that may be incorporated on current conventional configurations. In this way extensive changes in Aircraft Design paradigm are avoided, while high aircraft efficiency is obtained.

Aircraft cabin parameters were accounted for during the optimization process, as mentioned before. The cabin is the only aircraft component which suffers repetitive changes during the aircraft life. Section 10 presented the industry perspective on Cabin Design and Cabin Conversion activities and demonstrated their current and future economic impact through a market forecast. Section 11 offered an original mathematical alternative for optimizing the Cabin Conversion activity chain. From the perspective of Design Organizations performing Cabin Conversions, the process chain optimization is not only beneficial, but required by the certification authorities. A predefined organization of the engineering company is required for certifying work in the area of Cabin Conversions.

## **12.2 Summary of Theoretical Contributions**

Over twenty new equations and equation improvements were brought on theoretical level. These equations composed a balanced methodology for Aircraft Preliminary Design that includes analysis of new technologies applicable to conventional configurations:

- high by-pass ratio engines
- braced wing configuration
- natural laminar flow
- effect of winglets and wing span limitation increase

The methodology starts with Preliminary Sizing of aircraft, where essential parameters are determined and requirements are matched in a single chart. The requirements matching chart represents the solution of an intrinsic two-dimensional optimization problem. This solution is the design point given by the (best matching) couple thrust-to-weight ratio and wing loading.

The next step is taken towards Conceptual Design, first, by creating a responsive geometry of the entire aircraft. Emphasis was given to the calculation of basic cabin and cargo parameters. Second, by assessing the impact of geometry on wetted areas, zero-lift drag (including interference drag and wave drag), fineness ratio and mass.

After setting objectives, formal optimization, which incorporates matching chart optimization, is applied. This strategy represents a new approach in Preliminary Aircraft Design Optimization.

In order to create this balanced environment, where all parameter relations account for relative advantages and disadvantages, improvements were brought as follows:

- 1.) proposal of new mission fuel fractions for taxi, take-off, climb, descent and landing mission segments
- 2.) method for estimating Oswald efficiency factor
- 3.) method for estimating proportion of laminar flow as a function of the transition Reynolds number and leading edge sweep
- 4.) unified method for determining winglet efficiency
- 5.) incorporation of braced wing configuration
- 6.) incorporation of the latest preliminary design method on specific fuel consumption estimation able to account for high by-pass ratio engines
- 7.) incorporation of a constraint-responsive geometry for landing gear, able to account for the effects of new generation engines (with higher by-pass ratio)
- 8.) incorporation of landing gear mass estimation as a function of landing gear length
- 9.) method adjustment for wing thickness ratio
- 10.) estimation of aircraft sensitivity to gusts
- 11.) method for estimating generic cabin length and cabin length factor
- 12.) method for estimating the fuselage nose length
- 13.) method for estimating cargo compartment height
- 14.) method for estimating overhead stowage volume (per passenger)
- 15.) method for estimating sill height and cargo hold accessibility factor
- 16.) definition of Added Values for Aircraft Design
- 17.) incorporation of Added Values in a new, composed objective function; study on Added Value boundaries
- 18.) incorporation of decision making techniques and consistency estimation, utilization on Added Values evaluation
- 19.) utilization of matrix based methodology for process chain optimization
- 20.) many updated statistics (e.g. factors relating empennage parameters of wing parameters)
- 21.) extensive literature studies on key issues of this work



## 12.3 Conclusions on OPerA – Optimization in Preliminary Aircraft Design

The discussed methodology was created to be incorporated in a software tool able to respond to the questions defined in the problem statement:

- 1.) *Which values of the basic parameter combination in the initial design stage leads to an optimum aircraft design and through what means can these values be found?*
- 2.) *Which values of the basic parameter combination in the initial design stage that includes aircraft cabin parameters leads to an optimum aircraft design?*
- 3.) *How can a process chain for cabin conversions be optimized, by using a scientific approach?*

OPerA was built to function as a transparent tool for both design and optimization during aircraft project phase. Manual design and redesign cases can be studied (see the example of A320-Neo aircraft in Section 4.7) and automatic optimization of designs may be employed, either through own optimization codes (for single and multiple parameter variations) or by connecting the tool to Optimus®, a high level optimization software platform.

Regarding optimization, the purpose was not only producing the result itself, (i.e. untraceable, optimal parameter combination for a specific case). The purpose was also to create a tool able to assist the user in finding the arguments for the behavior of the resulting optimized design. As such, the major advantage of OPerA is that it *allows understanding the deep correlations of Aircraft Design, and confirms them by numbers.*

OPerA proved to fulfill all the goals set in the beginning of this research:

- It allows design space exploration and independent optimization of parameters in the Preliminary Design phase, where it is important to analyze as many configurations as possible.
- It is a simple tool that allows results traceability. For single and up to 4 parameter variations, plots may be produced for visualization.
- It allows analyzing not only conventional configuration, but also innovative configurations.
- It contains updated methods, and it represents in itself a unique synthesis of Aircraft Design equations, that showed reliability. In the same time, is a very open tool that allows ease incorporation of new ideas.
- It can be explored as a didactical tool, and aids the process of learning Aircraft Design.
- It builds on both classical and original objective functions.
- It includes expert knowledge, through weighted Added Values that increase potential revenue for airlines.

## 12.4 Conclusions on Optimization Results

Additionally to optimizing cabin parameters together with aircraft parameters, the novelty in applying optimization for producing results consisted in creating a composed objective function, based on economics and Added Values. It was concluded that, so far, aircraft were optimized mainly for cost efficiency. This objective remains valid also for the future: it is necessary that the future designs get better but also cheaper, in order to remain profitable. Based on the politics of saving money, Added Values - AV (i.e. quantified parameters that have the potential to bring more revenue to the airlines) were investigated. A number of 16 Added Values were incorporated, along with equivalent ton-mile Direct Operating Costs in a composed objective function. Weights were attributed following expert inquiries.

Tool capabilities were first proved by redesigning the A320-200 aircraft. This reference version was then optimized with OPerA. Three additional versions of the reference aircraft were tested: a version with braced wings, a version with Natural Laminar Flow capability and another version containing these two innovations at the same time. Optimization was performed for minimum Direct Operating Costs, minimum maximum take-off mass, minimum fuel mass and maximum Direct Operating Costs + Added Values. Optimization results produced with OPerA allowed confirmation of existing Aircraft Design statements or formulation of new ones.

The *optimization strategy* was to start with single Aircraft Design parameter variations and then combine them, step by step, with all cabin parameters and requirements. The optimization case that allowed the highest design freedom was to vary all design parameters (except number of engines and number of passengers), all requirements and to allow an increase in span limitation from the 36 m category to the 52 m category. This case was selected for inclusion in the work.

High improvements are obtained already by optimizing the standard configuration: 11.4 % costs reduction when optimizing for DOC; 20.1 % mass reduction when optimizing for maximum take-off mass, 45.7 % fuel reduction, when optimizing for fuel mass, and an increase of 40.9 % of the DOC + AV composed function (i.e. a score increase from 4.5 to 8.6 out of 10).

Adding (both) technologies, makes the design even more efficient: 15.8 % costs reduction when optimizing the A320-200 configuration with braced wings and natural laminar flow for minimum DOC; 24.4 % mass reduction when optimizing for maximum take-off mass; 49.7 % fuel reduction, when optimizing for fuel mass, and an increase of 48 % of the DOC + AV composed function.

For calculating DOC an aircraft delivery price was used that depends on operating empty mass. If the incorporated technologies, such as braced wing configuration, reduce mass, this is

beneficial for the costs. Yet, no penalty is included in OPerA for assessing the price of the technology, which in turn, would reflect detrimental on DOC.

Some remarks regarding the *objective functions* are: Minimum fuel mass takes the most advantage from design freedom; due to the span limitation increase, the aspect ratio increases very much as well as by-pass ratio (in conjunction with a lower altitude) in order to generate the fuel reduction. Nevertheless, the resulting extreme design alters the economic efficiency quite much (depending on how much aspect ratio is allowed to increase). Optimization for minimum  $m_{MTO}$  is similar to optimization for DOC, with the difference that it favors smaller speeds. When optimizing for DOC, as a secondary effect, fuel mass and maximum take-off mass have a quite good improvement. DOC + AV is an objective function that accounts better for cabin requirements, ground handling requirements, productivity, and taking-off also from smaller airports. Yet, due to limitation in landing and take-off field lengths, and increase in cabin comfort parameters, the design is less efficient than when optimizing for DOC alone. For all optimization runs range and payload were kept constant. If mass reductions are used for accommodating more payload or increasing range (as it is the case with the new A320 NEO version) then the design would become even more efficient.

The influence of *cabin parameters* on the aircraft design depends on the objective functions. Adding cabin parameters to the optimization runs when the objective is minimum DOC shows the (unsurprisingly) tendency towards minimum comfort standards. This results in additional improvements of 5.4 % on average for every major output. More precisely, additional improvements of 5.9 % for  $m_{MTO}$ , 6.1 % for  $m_F$  and 4.4 % for DOC are obtained, compared to the case when only aircraft parameters are varied (experiments 19a and b). As such, optimizing DOC makes sense more on a predefined cabin, unless the airline is happy with minimum standards, in which case the airline would save money. When optimizing for DOC+AV, some of the cabin parameters go towards minimum whereas other values go towards maximum values. This tendency is the result of the optimization between benefits of AV points for comfort and the burden in drag and mass caused by the increased size of the fuselage resulting from selected comfort measures. Optimizing for maximum DOC+AV shows parameter trends in which the cabin should be developed. Recognizing these trends should help support management decisions.

Regarding *technology insertions* the following statements result:

- Lower speeds (thus lower altitude) allow an increase in BPR and a reduction in drag, and thus dramatic fuel reduction.
- There is an optimum BPR for a given Mach number.
- Increased landing and take-off distance allow a smaller engine and thus a more efficient design for the same Mach number.
- Aircraft can be optimized with higher span, especially with a braced wing.
- Winglets are beneficial if span is limited.
- Span increase is more efficient than winglets.

- Braced wings allow a low wing sweep and enable Natural laminar flow (NLF).
- Braced wings alone are more efficient than NLF (on the wing) alone.
- If eco-efficiency is the goal, then the objective function should not be DOC.
- When optimizing for DOC, traditional cruise Mach number should be maintained.
- With increasing fuel prices, DOC optimized aircraft will be equal to  $m_F$  optimized aircraft.
- Cabin parameters are sensitive to objective functions, rather than to technology.

Regarding the investigation on the importance of *cabin activities* after the aircraft design is over, it can be concluded that:

- Cabin modifications occur in cycles and are very important during the aircraft life.
- This segment of aircraft exploitation is only little sensitive to economic crises, and very productive especially for VIP scenarios.
- The results of a 20 years forecast showed that there is and will be a high demand for this type of activities.
- The ability of an organization (different from the aircraft manufacturer) to perform modifications on aircraft (i.e. design, redesign and certification activities) needs to be proven by fulfilling a set of strict organizational requirements defined by certification authorities.
- An efficient Design Organization can be supported by process chain optimization techniques.
- A suitable (and original) process chain optimization technique for cabin upgrades and conversion activities is Dependency and Structure Modeling Methodology.
- The partitioning algorithm delivered the optimal sequence of the standard conversion processes.
- The eigenstructure analysis underlined those processes with the greatest influence on the engineering system.
- The cross impact diagram delivered groups of processes belonging to five spheres: reactive, dynamic, impulsive, low impact and neutral.
- Several categories of tools to support such work were identified and appropriate commercial tools were evaluated.
- Product Data Management (PDM) tools and Enterprise Resources Planning (ERP) tools are essential for reducing rework, for avoiding delays, thus for optimizing the functioning of Design Organizations.

To summarize, the contributions of this work are two-folded and cover several areas: First, on the *theoretical* level, through the methodology set up for Aircraft and Cabin Design and Conversion, and second on the *practical* level, by delivering a Preliminary Aircraft Design and Optimization tool, by building an Optimization Module able to compete with a commercial tool, by applying mathematical approaches to industry questions regarding Cabin Design and Cabin Conversions.



## 13 Outlook

OPerA – the materialization of the work performed, offers the designer the support, the transparency and the freedom required in a preliminary design stage. The tool is able to perform design assessments while facilitating the *understanding* of advantages and disadvantages of a multitude of Aircraft Design problems.

Three main directions of further research and development are possible:

- 1.) Further analysis of the mathematical side of optimization algorithms, and ultimately an extension of the optimization module;
- 2.) Further analysis of the Aircraft Design equations;
- 3.) Extension of OPerA for all classes of aircraft (such as CS-23, CS-VLA), and utilization of OPerA for diverse case studies (box wing, folding wing, etc).

At Hamburg University of Applied Sciences doctoral studies are undergoing that already use OPerA<sup>1</sup>. These studies analyze topics such as Smart Turboprop, Box Wing configuration or Strut Braced Wing configuration. A research proposal was written on the impact of span limitation increase, and the effect of changing the airport category on aircraft productivity.

The tool is currently being extended to cover propeller driven aircraft, under the name *PrOPerA*. A research on the required adaptations has been performed in the paper **Scholz 2009** (based on the results my diploma thesis, **Niță 2008**).

---

<sup>1</sup> URL: <http://Aero.ProfScholz.de/>



# List of Publications

- 1.) SCHOLZ, Dieter; NIȚĂ, Mihaela: Preliminary Sizing of Large Propeller Driven Aeroplanes. In: *Czech Aerospace Proceedings*, (2009), No. 2, S. 41-47. – ISSN: 1211—877X
- 2.) NIȚĂ, Mihaela; SCHOLZ, Dieter: The Process Chain to a Certified Cabin Design and Conversion. In: DGLR: *Deutscher Luft- und Raumfahrtkongress 2009 : Tagungsband - Ausgewählte Manuskripte* (DLRK, Aachen, 01.-04. September 2009). – ISBN: 978-3-932182-63-4. DocumentID: 121161. Download: <http://CARISMA.ProfScholz.de>
- 3.) NIȚĂ, Mihaela; SCHOLZ, Dieter: Business Opportunities in Aircraft Cabin Conversion and Refurbishing. In: *Journal of Aerospace Operations*. Amsterdam : IOS Press (2011), Vol. 1, No. 1-2, pp. 129-153. – ISSN 2211-002X
- 4.) NIȚĂ, Mihaela; SCHOLZ, Dieter: From Preliminary Aircraft Cabin Design to Cabin Optimization. In: *DGLR: Deutscher Luft- und Raumfahrtkongress 2010 : Tagungsband - Ausgewählte Manuskripte* (DLRK, Hamburg, 30.August-02. September 2010). – ISBN: 978-3-932073-87-9 ICAS 2010
- 5.) NIȚĂ, Mihaela; SCHOLZ, Dieter: Process Chain Analysis and Tools for Cabin Design and Redesign Activities. In: *CD Proceedings : ICAS 2010 - 27th Congress of the International Council of the Aeronautical Sciences* (ICAS, Nizza, 19.-24. September 2010). Edinburgh, UK : Optimage Ltd, 2010. – ISBN: 978-0-9565333-0-2. Paper: ICAS2010-7.3.4 (363.pdf). Download: <http://CARISMA.ProfScholz.de>
- 6.) NIȚĂ, Mihaela; SCHOLZ, Dieter: Parameter Optimization for an Interactive Aircraft Design, EWAD 2011 (10th European Workshop on Aircraft Design Education, University of Naples "Federico II", Italy, 24. - 27. May 2011 ). – Download: <http://OPerA.ProfScholz.de>
- 7.) NIȚĂ, Mihaela; SCHOLZ, Dieter: Parameter Optimization for an Interactive Aircraft Design (Aerodays 2011, Madrid, 30. March - 01. April 2011). – Poster for the Student Participation Program. Download: <http://OPerA.ProfScholz.de>
- 8.) NIȚĂ, Mihaela; SCHOLZ, Dieter: Estimating the Oswald Factor from Basic Aircraft Geometrical Parameters. In: *Publikationen zum DLRK 2012* (Deutscher Luft- und Raumfahrtkongress, Berlin, 10. - 12. September 2012). – URN: urn:nbn:de:101:1-201211164010. DocumentID: 281424

Paper to be published:

- 9.) NIȚĂ, Mihaela; SCHOLZ, Dieter: From Preliminary Aircraft Cabin Design to Cabin Optimization. In: *Scientific Bulletin*, University Politehnica Bucharest (paper sent, confirmation for publication received)





## List of References

- ACARE 2011** ADVISORY COUNCIL FOR AVIATION RESEARCH AND INNOVATION IN EUROPE (ACARE): *Latest ACARE Documents*. – URL: <http://www.acare4europe.com/documents/latest-acare-documents> and <http://www.acare4europe.com/> (2011-03-06)
- ACMG 2012** AIR CARGO MANAGEMENT GROUP: URL: <http://www.cargofacts.com/> (2012-02-11)
- AEA 1989a** ASSOCIATION OF EUROPEAN AIRLINES: *Short-Medium Range Aircraft AEA Requirements*. Brussels : AEA, 1989 (G(T)5656)
- AEA 1989b** ASSOCIATION OF EUROPEAN AIRLINES: *Long Range Aircraft AEA Requirements*. Brussels : AEA, 1989 (G(T)5655)
- AFPO 2006** AIRBUS FUTURE PROJECT OFFICE: *Airbus UK / University Design Project 2006/7: Task Proposal – Low Fare Airline Optimised Aircraft*. Airbus FPO, Ref.: EDXG1/MSC/KJM/20731C, October 2006.
- Airbus 2011** AIRBUS: *Airplane Characteristics for Airport Planning, AC A320*. Blagnac : Airbus SAS, 2005, Rev. 2011
- Airbus 2012** AIRBUS: *New “sharklets” and A320 NEO*. – URL: <http://www.airbus.com/aircraftfamilies/passengeraircraft/a320family/technology-and-innovation/> (2012-02-18)
- Ali 2002** ALI, N.; BEHDINAN, K.: Conceptual Aircraft Design: A Genetic Search and Optimization Approach. In: *CD Proceedings : ICAS 2002 - 23rd Congress of International Council of the Aeronautical Sciences* (Toronto, 08. - 13. September 2002). Edinburgh, UK : Optimage Ltd, 2002. – ISBN: 0-9533991-3-3. Paper: ICAS2002-1.1.4.
- Alonso 2006** ALONSO, J.A.; LAMATA, M.T.: Consistency in the Analytic Hierarchy Process: A new Approach. In: *International Journal of Uncertainty, Fuzziness and Knowledge-Based Systems*, Vol. 14 (2006), No. 4, pp. 445–459
- Amadori 2008** AMADORI, K.: *On Aircraft Conceptual Design: A Framework for Knowledge Based Engineering and Design Optimization*. Linköping, Linköping University, Institute of Technology, Studies in Science and Technology, Thesis No. 1366, 2008

- AMC 21** EUROPEAN AVIATION SAFETY AGENCY: *Acceptable Means of Compliance and Guidance Material to Part 21*, 2003. – URL: [http://easa.eu.int/ws\\_prod/g/doc/Agency\\_Mesures/Certification\\_Spec/decision\\_ED\\_2003\\_01\\_RM.pdf](http://easa.eu.int/ws_prod/g/doc/Agency_Mesures/Certification_Spec/decision_ED_2003_01_RM.pdf) (2009-07-08)
- Anderson 1996** ANDERSON, M.B.; GERBERT, G.A.: Using Pareto genetic Algorithms for Preliminary Subsonic Wing Design. In: *AIAA Meeting Papers on Disc*, 1996, pp. 363-371. – Paper: AIAA 96-4023, A9638738
- AP 1500** AIRBUS PROCEDURE: *AP1500 – General Requirements for Engineering Design Suppliers (GREDS)*, 2005
- AP 2289** AIRBUS: Airbus Procedure AP 2289: *Develop New Cabin & Cargo (DnCC) - The Process*, December 2003
- Arnoult 2007** ARNOULT, S.: Cabin Fever: Cabin makeovers come in cycles and the cycles keep getting shorter, In: *Air Transport World*, April 2007. – URL: <http://www.atwonline.com/magazine/article.html?articleID=1898> (2009-05-01)
- Bartolomei 2008** BARTOLOMEI, J.; COKUS, M.; DAHLGREN, J.; DE NEUFVILLE, R.; MALDONADO, D.; WILDS, J.: *Analysis and Application of Design Structure Matrix, Domain Mapping Matrix and Engineering System Matrix Frameworks*. Massachusetts Institute of Technology, Engineering Systems Division, 2008.
- Bartolomei 2009** BARTOLOMEI, J.; SILBEY, S.; HASTINGS, D.; DE NEUFVILLE, R.; RHODES, H.: Bridging the Unspannable Chasm: Qualitative Knowledge Construction for Engineering Systems. In: *Second International Symposium on Engineering Systems*, (MIT, Cambridge, Massachusetts, 15. - 17. June 2009)
- Bichlmaier 1999** BICHLMAIER, C.; GRUNWALD, S.: PMM - Process Module Methodology for Integrated Design and Assembly Planning. In: *Proceedings of the 4<sup>th</sup> Design for Manufacturing Conference* (Las Vegas, Nevada, 12-15 September 1999). – URL: [http://cadcam.yonsei.ac.kr/abstract\\_system/200301\\_processplan\\_pdf/pm.pdf](http://cadcam.yonsei.ac.kr/abstract_system/200301_processplan_pdf/pm.pdf) (2009-06-21)
- Boeing 2002** BOEING: Blended Winglets for Improved Airplane Performance. In: *Boeing AERO*, No. 17 (2002), pp. 16-31. – URL: [http://www.boeing.com/commercial/aeromagazine/aero\\_17/](http://www.boeing.com/commercial/aeromagazine/aero_17/) (2012-02-18)

- Boeing 2009** THE BOEING COMPANY: *Current Market Outlook 2009-2028*. – URL: <http://www.boeing.com/commercial/cmo/> (2009-04-10)
- Boeing 2012** URL: <http://www.boeing.com/commercial/707family/product.html> (2012-08-20)
- Böhnke 2011** BÖHNKE, D.; JEPSEN, J.; PFEIER, T.; NAGEL, B.; GOLLNICK, V.; Liersch, C.: An Integrated Method for Determination of the Oswald Factor in a Multi-Fidelity Design Environment. In: *CEAS: 3<sup>rd</sup> International Conference of European Aerospace Societies, AirSpace Conference : Proceedings* (CEAS2011, Venice, 24. - 28. October 2011), pp. 735-743 - ISBN: 978-88-96427-18-7.
- Box 1965** BOX, M.J.: A New Method of Constrained Optimization and a Comparison with Other Methods. In: *Computer Journal*, Vol. 8 (1965), pp.42-52
- Bradley 2010** BRADLEY, M.; et al.: *Subsonic Ultra Green Aircraft Research SUGAR : Final Review*. Boeing Research and Technology, NASA N+3, April 2010. – URL: [http://aviationweek.typepad.com/files/boeing\\_sugar\\_phase\\_i\\_final\\_review\\_v5.pdf](http://aviationweek.typepad.com/files/boeing_sugar_phase_i_final_review_v5.pdf) (2011-03-06)
- Brandt 1997** BRANDT, S.A.; STILES, R.J.; BERTIN, J.J.; WHITFORD, R.: *Introduction to Aeronautics: A design Perspective*. Reston, VA : AIAA Education Series, 1997
- Brink 1973** BRINK, K.B.; RIECK, G.: *Wartungsaufwandanalyse auf Systemebene: Qualitative und quantitative Wartbarkeits- und Zuverlässigkeitsanalysen*. Verein Deutscher Ingenieure, VDI Bildungswerk, 1973
- Browning 2001** BROWNING, T.: Applying the Design Structure Matrix to System Decomposition and Integration Problems: A Review and New Directions. In: *IEEE Transactions on Engineering Management*, Vol. 48 (2001), No. 3, pp. 292-306. – ISSN: 0018-9391, Download from Digital Library of URL: <http://dsmweb.org> (2009-06-21)
- Cantelimi 1998** CANTELIMI, F.J.; PELZ, R.B.; OGOT, M.M.: *Stochastic Optimization for Aircraft Preliminary Design*. American Institute of Aeronautics and Astronautics, 1998. – Paper: AIAA 98-4773, A98-39754

- Chai 1996** CHAI, S.T.; MASON, W.H.: *Landing Gear Integration in Aircraft Conceptual Design*. Virginia Polytechnic Institute and State University, Multidisciplinary Analysis and Design Center for Advanced Vehicles, MAD Center Report: MAD 96-09-01, 1996. – URL: [http://www.dept.aoe.vt.edu/~mason/Mason\\_f/M96SC.html](http://www.dept.aoe.vt.edu/~mason/Mason_f/M96SC.html) (2012-02-03)
- Chanas 2001** CHANAS, S.; ZIELI, P.: Critical Path Analysis in the Network with Fuzzy Activity Times. In: *Fuzzy Sets and Systems*, No. 122 (2001), pp. 195-204. – ISSN: 0165-0114, URL: <http://citeseerx.ist.psu.edu/viewdoc/download?doi=10.1.1.97.997&rep=rep1&type=pdf> (2009-06-22)
- Chen 1998** CHEN, G; YINGMING, H.; NÜBER, H.G.; WILKEN, D.: A method of Evaluating Civil Aircraft Market Adequacy. In: DGLR Fachausschuß S2 Luftfahrtsysteme: *Bewertung von Flugzeugen*. Proceedings of the Workshop. Garching, 26. - 27. October 1998. – URL: <http://www.fzt.haw-hamburg.de/pers/Scholz/dglr/bericht1098/Bericht1098.html> and <http://12.dglr.de> (2011-03-06)
- Clean Sky 2011** URL: <http://www.cleansky.eu/> and <http://www.cleansky.eu/content/page/gra-green-regional-aircraft> (2011-03-06)
- Crispin 1994** CRISPIN, Y.: Aircraft Conceptual Optimization Using Simulated Evolution. In: AIAA: *32nd AIAA Aerospace Sciences Meeting and Exhibit* (Reno, NV, 10. - 13. January 1994). Reno, NV : American Institute of Aeronautics and Astronautics, 1994. – Paper: AIAA 94-0092
- Crossley 1996** CROSSLEY, W.A.; LAANANEN, D.H.: Conceptual Design of Helicopters via Genetic Algorithm. In: *Journal of Aircraft*, Vol. 33 (1996), No. 6, pp. 1062-1070
- CS 23** EUROPEAN AVIATION SAFETY AGENCY: *Certification Specifications for Normal, Utility, Aerobatic, and Commuter Category Aeroplanes, CS-23, Amendment 2 (Corrigendum)*, Sep. 2008
- CS 25** EUROPEAN AVIATION SAFETY AGENCY: *Certification Specifications for Large Aeroplanes, CS-25*, Sep. 2008

- Dahl 2003** DAHL, V.R.: Holding Pattern for Freighters. In: *Air Cargo World*, 1 November 2003. – URL: [http://www.aircargoworld.com/features/1103\\_1.htm](http://www.aircargoworld.com/features/1103_1.htm) (2009-06-01)
- Danilovic 2007** DANILOVIC, M.; BROWNING, T.: Managing Complex Product Development Projects with Design Structure Matrices and Domain Mapping Matrices. In: *International Journal of Project Management*, No. 25 (2007), pp. 300-314
- De Falco 1995** DE FALCO, I.; DEL BALIO, R.; DELLA CIOPPA, A.; TARANTINO, E.: A Parallel Genetic Algorithm for Transonic Airfoil Optimization. In: *Proceedings of the IEEE International Conference on Evolutionary Computation* (Perth, University of Western Australia, 1995), pp. 429-434
- Deb 2002** DEB, K.: *Multi-Objective Optimization Using Evolutionary Algorithms*. Dordrecht : Kluwer Academic Publishers, 2002
- DeYoung 1955** DEYOUNG, J.; HARPER, C.W.: *Theoretical Symmetric Span Loading at Subsonic Speeds for Wings Having Arbitrary Plan Form*. Report No. 921, US Government Printing Office, 1955, pp. 593-648
- DeYoung 1980** DEYOUNG, J.: *Induced Drag Ideal Efficiency Factor of Arbitrary Lateral-Vertical Wing Forms*. NASA Contractor Report 3357, 1980
- Dirks 1999** DIRKS, G.A.; MEUSSEN, M.; SCHOLZ, D.: *Evaluation of MDO Tool iSIGHT*. Hamburg : DaimlerChrysler Aerospace Airbus, 1999. – TNEZB-17/99
- DLR 2009** DLR: INSTITUTE OF SPACE SYSTEMS, SYSTEM ANALYSIS SPACE SEGMENT. – URL: [http://www.dlr.de/irs/en/desktopdefault.aspx/tabid-4392/7172\\_read-10767](http://www.dlr.de/irs/en/desktopdefault.aspx/tabid-4392/7172_read-10767) (2009-06-22)
- Dodbele 1986** DODBELE, S.S.; VAN DAM, C.P.; VIJGEN, P.M.H.W.: *Design of Fuselage Shapes for Natural Laminar Flow*. NASA Contractor Report 3970. Langley : National Aeronautics and Space Administration, Scientific and Technical Information Branch, 1986. – Prepared for Langley Research Center under Contract NAS1-17926
- Driver 2006** DRIVER, J.; ZINGG, D.W.: Optimized Natural-Laminar-Flow Airfoils. In: AIAA: *44th AIAA Aerospace Sciences Meeting and Exhibit* (Reno, Nevada, 09. - 12. January 2006). Reno, Nevada : American

- Institute of Aeronautics and Astronautics, 2006. – Paper: AIAA-2006-247
- DSM 2009** URL: <http://dsmweb.org/> (2009-07-02). – DSM dedicated website, maintained by the Institute of Product Development, from Technical University München
- Dubs 1975** DUBS, F.: *Hochgeschwindigkeits-Aerodynamik*. Basel : Birkhäuser, 1975
- Eppinger 2002** EPPINGER, D.S.: *Managing Complex System Development Projects*, 2002. – URL: <http://mit.edu/eppinger/www/abstracts.html> (2009-06-22)
- ESA 2009** ESA: EUROPEAN SPACE AGENCY, CONCURRENT DESIGN FACILITY. – URL: <http://www.esa.int/SPECIALS/CDF/index.html> (2009-06-22)
- ESDU 1996** ESDU 74035: *Subsonic lift-dependent drag due to trailing vortex wake for wings without camber or twist*. Endorsed by The Royal Aeronautical Society, 1996
- Excel 2011a** MICROSOFT EXCEL HELP: *Excel specifications and limits*. – URL: <http://MS.EXCEL.12.1033/EXCEL/content/HP10073849.htm#WorksheetWorkbook> (2011-03-05)
- Excel 2011b** MICROSOFT HELP AND SUPPORT: *Solver Uses Generalized Reduced Gradient Algorithm*. – Article ID: 82890. URL: <http://support.microsoft.com/kb/82890/en-us> (2011-03-05)
- Feir 2001** FEIR, J.: Aircraft Useful Lives, Retirements and Freighter Conversions. In: *Speednews Aviation Industry Suppliers Conference*, Doylestown, 26. - 28. March 2001. – URL: <http://www.jackfeir.com/JackFeirPresentation.pdf> (2009-05-09)
- Fernandez 2001** FERNANDEZ DA MOURA, E.J.: *Vergleich verschiedener Verfahren zur Masseprognose von Flugzeugbaugruppen im frühen Flugzeugentwurf*. Hamburg University of Applied Sciences, Department of Automotive and Aeronautical Engineering, Diploma Thesis, 2001
- Flug 2012** URL: <http://www.flugzeuginfo.net> (2012-08-20)

- Gern 2000a** GERN, F.H.; KO, A.; SULAEMAN, E.; KAPANIA, R. K.; MASON; W.H.; GROSSMAN, B.: Passive Load Alleviation in the Design of a Strut-Braced Wing Transonic Transport. In: *8<sup>th</sup> AIAA/USAF/NASA/ISSMO Symposium on Multidisciplinary Analysis and Optimization* (Long Beach, CA, 6.-8. September 2000). Long Beach : American Institute of Aeronautics and Astronautics, 2000. – Paper: AIAA 2000-4826
- Gern 2000b** GERN, F.H.; SULAEMAN, E.; NAGHSHINEH-POUR, A.; KAPANIA, R.K.; HAFTKA, R.T.: Flexible Wing Model for Structural Wing Sizing and Multidisciplinary Design Optimization of a Strut-Braced Wing. In: *41st AIAA/ASME/ASCE/AHS/ASC Structures, Structural Dynamics, and Materials Conference and Exhibit* (Atlanta, GA, 03. - 06. April 2000). – Paper: AIAA 2000-1327, URL: [http://archive.org/details/nasa\\_techdoc\\_20000023179](http://archive.org/details/nasa_techdoc_20000023179)
- Gern 2005** GERN, F.H.; KO, A.; GROSSMAN, B.; HAFTKA, R.; KAPANIA, R.K.: Transport Weight Reduction through MDO: The Strut-Braced Wing Transonic Transport. In: *AIAA: 35th AIAA Fluid Dynamics Conference and Exhibit* (Toronto, Ontario, 06. - 09. June 2005). Toronto : American Institute of Aeronautics and Astronautics, 2005. - Paper: AIAA 2005-4667
- Giannakoglou 2008a** GIANNAKOGLU, K.C.; KAMPOLIS, I.C.; GEORGOPOULOU, C.A.: Metamodel-Assisted Evolutionary Algorithms. In: PÉRIAUX, J.; DECONINCK, H. (Eds.): *Introduction to Optimization Methods for Multidisciplinary Design in Aeronautics and Turbomachinery (von Karman Institute for Fluid Dynamics, Lecture Series 2008-07)*. Belgium : VKI, 2008. – ISBN 978-2-930389-86-9
- Giannakoglou 2008b** GIANNAKOGLU, K.C.; PAPADIMITRIOU, D.I.; KAMPOLIS, I.C.: Hybridized Adjoint Methods / Evolutionary Algorithms and Applications to Turbomachinery. In: PÉRIAUX, J.; DECONINCK, H. (Eds.): *Introduction to Optimization Methods for Multidisciplinary Design in Aeronautics and Turbomachinery (von Karman Institute for Fluid Dynamics, Lecture Series 2008-07)*. Belgium : VKI, 2008. – ISBN 978-2-930389-86-9
- Goldberg 2011** GOLDBERG, A.: *Fahrwerksauslegung im Flugzeugentwurf und Berechnung der Bodenbelastung in PreSto*. Hamburg University of Applied Sciences, Department of Automotive and Aeronautical Engineering, Project, 2011



- Gonzales 2004a** GONZALES, L.; WHITNEY, E.; SRINIVAS, K.; PERIAUX, J.: Multidisciplinary Aircraft Design and Optimization using a Robust Evolutionary Technique with Variable Fidelity Models., In: *CD Proceedings of the 10<sup>th</sup> AIAA/ISSMO Multidisciplinary Analysis and Optimization Conference* (Albany, N.Y., 30. August - 01. September 2004). Albany : American Institute of Aeronautics and Astronautics, 2004. – Paper: AIAA 2004-4625
- Gonzales 2004b** GONZALES, L.F.; WHITNEY, E.J.; PÉRIAUX, J.; SEFRIQUI, M.; Srinivas, K.: A Robust Evolutionary Technique for Inverse Aerodynamic Design: Design and Control of Aerospace Systems Using Tools from Nature. In: NEITTAANMÄKI, P.; ROSSI, T.; KOROTOV, S.; ONATE, E.; PÉRIAUX, J.; KRNOZER, D. (Eds.): *Proceedings of the 4<sup>th</sup> European Congress on Computational Methods in Applied Sciences and Engineering, Volume II*, (ECCOMAS 2004, Jyväskylä, Finland, 24. - 28. July 2004). Jyväskylä, Finland : University of Jyväskylä, 2004. – ISBN 951-39-1869-6
- Gonzales 2008** GONZALES, L.: MOO Methods for Multidisciplinary design using Parallel Evolutionary Algorithms, Game Theory and Hierarchical Topology: Numerical Aspects and Implementation of Model Test Cases. In: PÉRIAUX, J.; DECONINCK, H. (Eds.): *Introduction to Optimization Methods for Multidisciplinary Design in Aeronautics and Turbomachinery (von Karman Institute for Fluid Dynamics, Lecture Series 2008-07)*. Belgium : VKI, 2008. – ISBN 978-2-930389-86-9
- Grasmeyer 1997** GRASMEYER, J.: *A discrete Vortex Method for Calculating the Minimum Induced Drag and Optimum Load Distribution for Aircraft Configurations with Noncoplanar Surfaces*. Virginia Polytechnic Institute and State University, Department of Aerospace and Ocean Engineering, 1997.
- Grasmeyer 1998a** GRASMEYER, J.M.: *Multidisciplinary Design Optimization of a Strut-Braced Wing Aircraft*. Faculty of the Virginia Polytechnic Institute and State University, Master Thesis, 1998
- Grasmeyer 1998b** GRASMEYER, J.M: *Multidisciplinary Design Optimization of a Strut-Braced Wing Aircraft with Tip-Mounted Engines*. Virginia Polytechnic Institute and State University, Multidisciplinary Analysis and Design Center for Advanced Vehicles, MAD Center Report: MAD 98-01-01, 1998

- Greatwood 2006** GREATWOOD, C.; et al.: *Strut Braced Wing Aircraft - Preliminary Engineering Definition Report*. University of Bristol and Airbus, 2006. – URL: <http://www.bris.ac.uk/aerospace/msc/avadi/units/projects/ub2007/group2/pedr.pdf> (2011-03-05)
- Grosu 1965** GROSU, I.: *Calculul și construcția avionului, Vol.1*. Buchaest : Editura didactică și pedagogică, 1965
- Gundlach 1999** GUNDLACH IV, J.F.: *Multidisciplinary Design Optimization and Industry Review of a 2010 Strut-Braced Wing Transonic Transport*. Blacksburg, VA, Virginia Polytechnic Institute and State University, Department of Aerospace and Ocean Engineering, Multidisciplinary Analysis and Design Center for Advanced Vehicles, Report MAD 99-06-03, 1999. – URL: [http://www.dept.aoe.vt.edu/~mason/Mason\\_f/MAD990603.pdf](http://www.dept.aoe.vt.edu/~mason/Mason_f/MAD990603.pdf) (2011-03-06)
- Gundlach 2000** GUNDLACH IV, J.F.; TÉTRAULT, P-A.; GERN, F.; NAGSHINEH-POUR, A.; KO, A.; SCHETZ, J.A.; MASON, W.H.; KAPANIA, R.; GROSSMAN, B.: *Multidisciplinary Design Optimization of a Strut-Braced Wing Transonic Transport*. In: *38th Aerospace Sciences Meeting & Exhibit* (Reno, Nevada, 10. - 13. January 2000). Reno : American Institute of Aeronautics and Astronautics, 2000. – Paper: AIAA 2000-0420
- Hepperle 2008** HEPPERLE, M.: *MDO of Forward Swept Wings : Presentation at KATnet II Workshop*. Braunschweig, 28. - 29. January 2008
- Herrmann 2010** HERRMANN, S.: *Untersuchung des Einflusses der Motorenzahl auf die Wirtschaftlichkeit eines Verkehrsflugzeuges unter Berücksichtigung eines optimalen Bypassverhältnisses*. Berlin, Technical University, Institute for Aerospace Sciences, Department of Aircraft and Lightweight Constructions, Graduation Thesis, 2010
- Hoak 1978** HOAK, D.E.: *USAF Stability and Control Datcom*, Wright-Patterson Air Force Base, Air Force Flight Dynamics Laboratory, Flight Control Division, Ohio, 1978. – Sale: NTIS
- Holmes 1986** HOLMES, B.J.; CROOM, C.C.; HASTINGS, E.C.; OBARA, C.J.; VAN DAM, C.P.: *Flight Research on Natural Laminar Flow*. In: *Langley Symposium on Aerodynamics* (NASA Langley Research Center, 1986), Vol. 1 (1986), pp. 461-474. – Document ID: 19880005568, Accession Number: 88N14950, SEE N88-14926 07-01. URL: [http://hdl.handle.net/2060/1988\\_0005568](http://hdl.handle.net/2060/1988_0005568) (2013-02-02)

- Hongman 2004** HONGMAN, K.; MALONE, B.; SOBIESZCZANSKI-SOBIESKI, J.: A Distributed, Parallel, and Collaborative Environment for Design of Complex Systems. In: AIAA: *45<sup>th</sup> AIAA/ASME/ASCE/AHS/ASC Structures, Structural Dynamics and Materials Conference* (Palm Springs, California, 19. - 22. April 2004). Palm Springs : American Institute of Aeronautics and Astronautics, 2004. – Paper: AIAA 2004-1848. URL: <http://www.phoenix-int.com/documents/DesignofComplexSystems.pdf> (2011-09-27)
- Hörner 1951** HÖRNER, S.F.: *Fluid Dynamic Drag*. Otterbein Press, Dayton Ohio, 1951.
- Howe 2000** HOWE, D.: *Aircraft Conceptual Design Synthesis*. London : Professional Engineering Publishing, 2000
- ICAO 2004** INTERNATIONAL CIVIL AVIATION ORGANIZATION (ICAO): *Annex 14 to the Convention on International Civil Aviation : Aerodromes, Volume 1, Aerodrome Design and Operations*. ICAO, July 2004
- Isikveeren 2002** ISIKVEEREN, A.T.: *Quasi-Analytical Modelling and Optimisation Techniques for Transport Aircraft Design*. Stockholm, Royal Institute of Technology (KTH), Department of Aeronautics (Flygteknik), Doctoral Thesis, Report 2002-13, 2002
- Jackson 2007** JACKSON, P.: *Jane's all the Worlds Aircraft 2007-08*. Couldsdon : Cambridge University Press, 2007
- JAR OPS** JOINT AVIATION REQUIREMENTS: *JAR-OPS 1, Commercial Air Transportation (Aeroplanes)*, Amendment 13, May 2007. – URL: <http://www.jaa.nl/publications/jars/jar-ops-1.pdf> (2009-01-22)
- Jenkinson 1999** JENKINSON, L.R.; SIMPKIN, P.; ROHDES, D.: *Civil Jet Aircraft Design*. Burlington : Butterworth-Heinemann Publications, 1999
- Jobe 1979** JOBE, C.E.; KULFAN, R.M.; VACHAL, J.D.: Wing Planforms for Large Military Transports. In: *Journal of Aircraft*, Vol. 16 (1979), No. 7, pp. 425-432. – Article no. 78-1470
- Johanning 2012** JOHANNING, A.; SCHOLZ, D.: Evaluation of Worldwide Noise and Pollutant Emission Costs for Integration into Direct Operating Cost Methods. In: *Publikationen zum DLRK 2012* (Deutscher Luft- und Raumfahrtkongress, Berlin, 10. - 12. September 2012). – URN:

- Jones 1998** JONES, B.; CROSSLEY, W.; LYRINTZIS, A.: Aerodynamic and Aeroacoustic Optimization of Airfoils via a Parallel Genetic Algorithm. In: *Proceedings of Seventh AIAA/USAF/NASA/ISSMO Symposium on Multidisciplinary Analysis and Optimization* (St. Louis, Missouri, September 1998). St. Louis : American Institute of Aeronautics and Astronautics, 1998. – Paper: AIAA 98-4811
- Kingsley-Jones 2010** KINGSLEY-JONES, M.: Farnborough : A350's race against time. In : *Flight International*, 13 July 2010. – URL: <http://www.flightglobal.com/news/articles/farnborough-a350s-race-against-time-344205/> (2010-07-12)
- Knight 2001** KNIGHT, D.: Application of Genetic Algorithms to High Speed Air Intake Design. In: GIANNAKOGLU, K.C.; TSAHALIS, D.T.; PÉRIAUX, J.; PAPAILIOU, K.D.; FOGARTY, T. (Eds.): *Evolutionary Methods for Design Optimization and Control with Applications to Industrial Problems*, pp. 43-50. Athens : International Center for Numerical Methods in Engineering (CIMNE), 2001.
- Ko 2000a** Ko, A.: *The Role of Constraints and Vehicle Concepts in Transport Design: A Comparison of Cantilever and Strut-Braced Wing Airplane Concepts*. Faculty of the Virginia Polytechnic Institute and State University, Master Thesis, 2000
- Ko 2000b** KO, A; GROSSMAN, B.; MASON, W.H.: The Role of Constraints in the MDO of a Cantilever and Strut-Braced Wing Transonic Commercial Transport Aircraft. In: AIAA, SAE: *World Aviation Conference* (San Diego, CA, 10. - 12. October 2000). – Paper: 2000-01-5609
- König 2008** KÖNIG, C.; KREIMEYER, M.; BRAUN, T.: Multiple-Domain Matrix as a Framework for Systematic Process Analysis. In: *10<sup>th</sup> International Design Structure Matrix Conference, DSM'08*, (Stockholm, Sweden, 11. - 12. November 2008), München : Hanser, pp. 231–244. – ISBN: 978-3-446-41825-7
- Kroo 1994** KROO, I.; ALTUS, S.; BRAUN, R.; GAGE, P.; SOBIESKI, I.: Multidisciplinary Optimization Methods for Aircraft Preliminary Design. In: *Fifth AIAA/USAF/NASA/ISSMO Symposium on Multidisciplinary Analysis and Optimization* (Panama City, Florida,

07. - 09. September 1994). Panama City : American Institute of Aeronautics and Astronautics, 1994. – Paper: AIAA 94-4325

- Kroo 2001** KROO, I.: Drag Due to Lift: Concepts for Prediction and Reduction. In: *Annual Reviews, Fluid Mechanics*, Vol. 33 (2001), pp. 587–617
- Kroo 2005** KROO, I.: Nonplanar Wing Concepts for Increased Aircraft Efficiency. In: TORENBECK, E.; DECONINCK, H. (Eds.): *Innovative Configurations and Advanced Concepts for Future Civil Aircraft (von Karman Institute for Fluid Dynamics, Lecture Series 2005-06)*. Belgium : VKI, 2005. – ISBN 2-930389-62-1
- Kroo 2006** KROO, I.; SHEVELL, R.: *Aircraft design : Synthesis and Analysis*, Version 1.2. Stanford : Desktop Aeronautics, Inc., , 2006. – URL: <http://adg.stanford.edu/aa241/AircraftDesign.html> and [http://adg.stanford.edu/aa241/drag/cdc\\_intro.html](http://adg.stanford.edu/aa241/drag/cdc_intro.html) (2011-03-06)
- Kulfan 1978** KULFAN, R.M.; VACHAL, J.D.: *Wing Planform Geometry Effects on Large Subsonic Military Transport Airplanes*. Boeing Commercial Airplane Company, AFFDL-TR-78-16, February 1978.
- Kundu 2010** KUNDU, A.K.: *Aircraft Design*. New York : Cambridge University Press, 2010
- Laarhoven 1987** LAARHOVEN, P.J.M.; AARTS, E.H.L.: *Simulated Annealing: Theory and Applications*. Dordrecht : Kluwer Academic Publishers, 1987
- Lambert 1997** LAMBERT, M.: *Jane's all the World's Aircraft*, 1997. – Jane's Information Group, 163 Brighton Road, Coulsdon, Surrey CR5 2NH, UK
- Lambert 2001** LAMBERT, M.: *Jane's all the World's Aircraft*, 2001. – Jane's Information Group, 163 Brighton Road, Coulsdon, Surrey CR5 2NH, UK
- Lasdon 1974** LASDON, L.S.; FOX, R.; RATNER, M.: Nonlinear Optimization Using the Generalized Reduced Gradient Method. In: *Revue Francaise d'Automatique, d'Informatique, et de Recherche Operationnelle (R.A.I.R.O.)*, Vol. 3,(1974), pp. 73-104

- Lavelle 1994** LAVELLE, M.T.; CURLETT, P.B.: *Graphical User Interface for the NASA FLOPS Aircraft Performance and Sizing Code*. NASA Lewis Research Center, NASA Technical Memorandum 106649, 1994
- Lee 2007** LEE, D.S.; GONZALES, L.F.; SRINIVAS, K.; PÉRIAUX, J.: An Evolutionary Robust Optimization Method for the Wing Drag/RCS Reduction with Uncertain Operating Flight Condition Parameters. Applications to the Design of UCAVs systems. In: *Intelligent Computing in Mechanics and USNCCM9* (San Francisco, USA, 23. - 26. July, 2007)
- Lee 2008** LEE, D.S.: *Uncertainty Based MultiObjective and Multidisciplinary Design Optimization in Aerospace Engineering*. New South Wales, Australia, University of Sydney, Doctoral Thesis, 2008
- Loftin 1980** LOFTIN, L.K.: *Subsonic Aircraft: Evolution and the Matching of Size to Performance*. Hampton, Langley : National Aeronautics and Space Administration, Research Center, 1980. – NASA Reference Publication 1060
- LTH 2008** LTH: *Luftfahrttechnisches Handbuch Edition 2008, Volume MA Masseanalyse*, 2008. URL: <http://www.lth-online.de/> (2011-09-27)
- MAD 2011** MULTIDISCIPLINARY ANALYSIS AND DESIGN (MAD) CENTER FOR ADVANCED VEHICLES. – URL: <http://www.dept.aoe.vt.edu/research/groups/mad/> (2011-03-06) and <http://www.dept.aoe.vt.edu/research/groups/tbw/> (2011-03-06)
- Marco 1989** MARCO, N.; LANTERI, S.; DESIDERI, J.A.; PÉRIAUX, J.: A Parallel Genetic Algorithm for Multi-objective Optimization in Computational Fluid Dynamics. In: MIETTINEN, K.; MÄKELÄ, M.M.; NEITTAANMÄKI, P.; PÉRIAUX, J. (Eds.): *Evolutionary Algorithms in Engineering and Computer Science*. Chichester, UK : Wiley & Sons, 1999, pp. 445-456
- Markwardt 1998** MARKWARDT, K.: *Flugzeugentwurf (Aircraft Design)*. Hamburg University of Applied Sciences, Department of Automotive and Aeronautical Engineering, Lecture Notes, 1998
- Mason 2006** MASON, W.H.: *AOE 4124 Configuration Aerodynamics*. Virginia Polytechnic Institute and State University, Aerospace and Ocean Engineering Department, Lecture Notes, 2006. – URL: <http://www.de>

pt.aoe.vt.edu/~mason/Mason\_f/ConfigAero.html and [http://www.dept.aoe.vt.edu/~mason/Mason\\_f/ConfigAeroTransonics.pdf](http://www.dept.aoe.vt.edu/~mason/Mason_f/ConfigAeroTransonics.pdf) (2012-03-01)

- Mattingly 1996** MATTINGLY, J.D.: *Elements of Gas Turbine Propulsion*. USA : McGraw-Hill, 1996
- Mayer 1995** MAYER, J.R.; MENZEL, P.C.; PAINTER, K.M.; DEWITTE, S.P.; BLINN, T.; PERAKATH, B.: *Knowledge Based Systems, Logistics Research Division: Information for Concurrent Engineering (IICE): IDEF 3 Process Description Capture Method Report*. Texas : Knowledge Based Systems, 1995. – 1500 University Drive East College Station, Texas 77840-2335. Interim Technical Report for Period April 1992 - September 1995
- McCormick 1995** MCCORMICK, B.: *Aerodynamics, Aeronautics, and Flight Mechanics*. New York : John Wiley and Sons, Inc., 1995
- Mechler 2002** MECHLER, H.: *Synthese und Analyse im parametrischen Flugzeugvorentwurf*. München, Technical University, Faculty of Mechanical Engineering, Doctoral Thesis, 2002
- Meller 1998** MELLER, F.; JOST, P.: Key Buying Factors and Added Value – a New Approach to Aircraft Evaluation. In: DGLR Fachausschuß S2 Luftfahrtsysteme: *Bewertung von Flugzeugen*. Proceedings of the Workshop. Garching, 26. - 27. October 1998. – URL: <http://www.fzt.haw-hamburg.de/pers/Scholz/dglr/bericht1098/Bericht1098.html> and <http://12.dglr.de> (2011-03-06)
- Metzger 2008** METZGER, R.: *Gesamtheitliche Optimierung von Rumpfquerschnitten im Flugzeugvorentwurf*. München : Dr. Hut, 2008. – Technical University München, Chair of Lightweight Constructions, Doctoral Thesis. ISBN 978-3-89963-814-1
- Miller 1956** MILLER, G., A.: The magical number seven, plus or minus two: some limits on our capacity for processing information. In: *The Psychological Review*, No. 63 (1956), pp. 81-97.
- Moen 2010** MOEN, C.D.; GUEST, J.K.: *Truss-Braced Wing Topology Optimization Studies*. Springfield, VA : NBM Technologies, Inc., 2010
- MPC 75** URL: <http://MPC75.ProfScholz.de/> (2012-08-20)

- Müller 2003** MÜLLER, F. : *Flugzeugentwurf: Entwurfssystematik, Aerodynamic, Flugmechanik und Auslegungsparameter für kleiner Unterschallflugzeuge*. Fürstenfeldbruck : Dieter Thoms, 2003. – Source in **Müller 2003** from: ZIMMER, H.: Optimale Mehrdecker- und Einzelflügel-Konfigurationen.
- Nagalingam 2002** NAGALINGAM, S.; HARRIS, H.R.: *A Guide to Introducing Concurrent Engineering in Your Organisation*. National Institute for Manufacturing Management (Smart Link), 2002. – Based on research conducted at the Centre for Advanced Manufacturing Research (CAMR), of the University of South Australia. URL:<http://www.smartlink.net.au/library/concurrent.pdf> (2009-06-22)
- Naghshineh-Pour 1998** NAGHSHINEH-POUR, A.H.: *Structural Optimization and Design of a Strut-Braced Wing Aircraft*. Faculty of the Virginia Polytechnic Institute and State University, Master Thesis, 1998
- Nam 2001** NAM PYO SUH: *Axiomatic Design –Advances and Applications*. New York : Oxford University Press, 2001
- Nelder 1965** NELDER, J.A.; MEAD, R.: A Simplex Method for Function Minimization. In: *Computer Journal*, Vol. 7 (1965), pp.308-313
- Niță 1984** NIȚĂ, M.M.; PATRAULEA, R.; SÂRBU, A.: *Mecanica Aeronavelor*. Bucharest, 1984
- Niță 2008** NIȚĂ, M.F.: *Aircraft Design Studies on ATR72 Aircraft*. Hamburg University of Applied Sciences, Politehnica University Bucharest, Diploma Thesis, 2008
- Niță 2010** NIȚĂ, M.; SCHOLZ, D.: From Preliminary Aircraft Cabin Design to Cabin Optimization. In: *DGLR: Deutscher Luft- und Raumfahrtkongress 2010 : Tagungsband - Manuskripte* (DLRK, Hamburg, 31. August - 02. September 2010). – ISBN: 978-3-932182-68-5. DocumentID: 161168
- Niță 2011** NIȚĂ, M.F.; SCHOLZ, D.: Business Opportunities in Aircraft Cabin Conversion and Refurbishing. In: *Journal of Aerospace Operations*. Amsterdam : IOS Press, Vol. 1 (2011), No. 1-2, pp. 129-153. – ISSN 2211-002X



- Niță 2012** NIȚĂ, M.F.; SCHOLZ, D.: Estimating the Oswald Factor from Basic Aircraft Geometrical Parameters. In: *Publikationen zum DLRK 2012* (Deutscher Luft- und Raumfahrtkongress, Berlin, 10. - 12. September 2012). – URN: urn:nbn:de:101:1-201212176728. DocumentID: 281424. Download: <http://OPerA.ProfScholz.de>
- Noesis 2008** NOESIS SOLUTIONS: *OPTIMUS Theoretical Background*. Leuven, Belgium, 2008
- Noesis 2011** NOESIS SOLUTIONS: *Optimus Functions*. – URL: <http://www.noesis-solutions.com/Noesis/optimus-functions> (2011-09-27)
- Noran 2000** NORAN, O.: *Business Modeling: UML vs. IDEF*. Griffith University, School of Computing and Information Technology, 2000. – URL: <http://www.cit.gu.edu.au/~noran/Docs/UMLvsIDEF.pdf> (2009-06-21)
- Obayashi 1997a** OBAYASHI, S.; TSUKAHARA, T.: Comparison of Optimization Algorithms for Aerodynamic Shape Design. In: *AIAA Journal*, Vol. 35 (1997), No. 8, pp. 1413-1415
- Obayashi 1997b** OBAYASHI, S.: Aerodynamic Optimization with Evolutionary Algorithms. In: MANNA, M. (Eds.): *Inverse Design and Optimisation Methods (von Karman Institute for Fluid Dynamics, Lecture Series 1997-05)*. Belgium : VKI, 1997
- Obayashi 1998** OBAYASHI, S.: Multidisciplinary Design Optimization of Aircraft Wing Planform Based on Evolutionary Algorithms. In: *Proceedings of the 1998 IEEE International Conference on Systems, Man and Cybernetics, Vol. 4* (IEEE, La Jolla, California, 11. - 14. October 1998). San Diego : IEEE, 1998, pp. 3148-3153. – ISBN: 0-7803-4778-1
- Obert 2009** OBERT, E.: *Aerodynamic Design of Transport Aircraft*. Delft : IOS Press, 2009
- Ostrower 2011** OSTROWER, J.: Boeing takes it slow on Max. In: *Flight International*, 6-12 (2011), pp. 7
- Ottermann 2011** OTTERMANN, H.: Optimale Sill Height : Interview. Hamburg University of Applied Sciences, 2011-11-29

- Oyama 2002** OYAMA, A.; LIU, M.S.; OBAYASHI, S.: Transonic Axial Flow-Blade Shape Optimization Using Evolutionary Algorithm and Three-Dimensional Navier-Stokes Solver. In: *9<sup>th</sup> AIAA/ISSMO Symposium on Multidisciplinary Analysis and Optimization* (Atlanta, Georgia, 04. - 06. September 2002). Atlanta : American Institute of Aeronautics and Astronautics, 2002. – Paper: AIAA 2002-5642
- Pace 1995** PACE GMBH: *Future Project Cabin Configuration - Feasibility Study (Phase I)*. Toulouse : Airbus Industrie, ED-X, 1995
- Park 1978** PARK, P.H.: The Effect of Block Fuel Consumption of a Strutted vs. Cantilever Wing for a Short-Haul Transport Including Aeroelastic Considerations. In: *AIAA: Aircraft Systems and Technology Conference* (Los Angeles, CA, 21. - 23. August, 1978). – Paper: AIAA 78-1454
- Parker 2008** PARKER, D.A.: Incredible Interiors: Modern VIP Cabins. In: *Aviation Today Daily Brief*, 1 November 2008. – URL: <http://www.aviationtoday.com/am/categories/bga/Incredible-Interiors-Modern-VIPCabins27215.html> (2009-06-15)
- Part 21** EUROPEAN AVIATION SAFETY AGENCY: *Commission Regulation (EC) No 1702/2003, Annex Part 21*, Sep. 2003. – URL: [http://eur-lex.europa.eu/LexUriServ/site/en/oj/2003/l\\_243/l\\_24320030927en00060079.pdf](http://eur-lex.europa.eu/LexUriServ/site/en/oj/2003/l_243/l_24320030927en00060079.pdf) (2009-02-17)
- Périaux 2002** PÉRIAUX, J.; SEFRIOUI, M.; WHITNEY, E.; GONZALES, L.; SRINIVAS, K.; Wang, J.: Multi-Criteria Aerodynamic Shape Design Problems in CFD Using a Modern Evolutionary Algorithm on Distributed Computers. In: ARMFIELD, S.; MORGAN, P.; SRINIVAS, K. (Eds.): *Proceedings of the Second International Conference on Computational Fluid Dynamics (ICCFD2)* (Sydney, Australia, July 2002). Sydney : Springer, 2002
- Petscher 2009** PETSCHER, H.: Aufbau einer DOA Organisation : Meeting discussion. Hamburg, 2009-03-11
- Pfenninger 1958** PFENNINGER, W.: *Design Considerations of Large Subsonic Long Range Transport Airplanes with Low Drag Boundary Layer Suction*. Northrop Aircraft, Inc., Report NAI-58-529 (BLC-111), 1958. – Available from DTIC as AD 821 759

- Phleps 2009** PHLEPS, P.: Szenariostudie im Rahmen des Spitzencluster Leuchtturmprojektes „Effizienter Flughafen“ : Workshop presentation. Hamburg, 14. - 15. October 2009
- Pimmler 1994** PIMMLER, T.; EPPINGER, S.: Integration Analysis of Product Decomposition. In: HIGHT, T.K.; MISTREE, F. (Eds.): *Design Theory and Methodology Conference* (Minneapolis MN, September 1994). New York : ASME, 1994. – ISBN: 0-7918-1282-0, Download from Digital Library of URL: <http://dsmweb.org> (2009-06-21)
- Prandtl 1924** PRANDTL, L.: *Induced Drag of Multiplanes*. Hampton : National Advisory Committee for Aeronautics, 1924. – NACA TN 182
- Press 2011** *Press Releases and URLs on A320-NEO:*  
 URL: <http://www.airbus.com/aircraftfamilies/passengeraircraft/a320family/technology-and-innovation/> (2011-03-06),  
 URL: <http://www.airbus.com/presscentre/pressreleases/press-release-detail/detail/transaero-airlines-firms-up-order-for-eight-a320neo-aircraft/> (2011-03-06),  
 URL: <http://australianaviation.com.au/2010/12/airbus-neo-launch-imminent/> (2011-03-06) and  
 URL: [http://en.wikipedia.org/wiki/Airbus\\_A320neo\\_family](http://en.wikipedia.org/wiki/Airbus_A320neo_family) (2011-03-06)
- Price 1997** PRICE, K.; STORN, N.: Differential Evolution. In: *Dr.Dobb's Journal*, pp. 18-24, April 1997
- Quagliarella 1999** QUAGLIARELLA, D.; VICINI, A.: Designing High-Lift Airfoils Using Genetic Algorithms. In: MIETTINEN, K.; MÄKELÄ, M.M.; NEITTAANMÄKI, P.; PÉRIAUX, J. (Eds.): *Proceedings of EUROGEN'99 - Short Course on Evolutionary Algorithms in Engineering and Computer Sciences* (Jyväskylä, Finland, May 1999). Jyväskylä : University of Jyväskylä, Department of Mathematical Information Technology, 1999. – Series A. Collections (1999), No. 2, ISBN 951-39-0473-3
- Rai 2008** RAI, M.M.: Single- and Multiple-Objective Optimization with differential Evolution and Neural Networks. In: PÉRIAUX, J.; DECONINCK, H. (Eds.): *Introduction to Optimization Methods for Multidisciplinary Design in Aeronautics and Turbomachinery (von Karman Institute for Fluid Dynamics, Lecture Series 2008-07)*. Belgium : VKI, 2008. – ISBN 978-2-930389-86-9

- Raymer 1999** RAYMER, D.P.: *Aircraft Design: A Conceptual Approach*. Washington D.C. : AIAA Education Series, 1999
- Raymer 2002** RAYMER, D.P.: *Enhancing Aircraft Conceptual Design Using Multidisciplinary Optimization*. Stockholm, Royal Institute of Technology, Department of Aeronautics, Doctoral Thesis, 2002. – ISBN 91-7283-259-2, URL: <http://www.aircraftdesign.com/RaymerThesisFinalRevLowRes.pdf> (2010-03-03)
- Reis 2010** REIS, G.: *Systems Architectural Development: A New Paradigm for Early-Stage Design*. Atlanta : PACE America Inc., 2010. – URL: <http://www.pace.de> (2010-03-03)
- Rizzo 2007** RIZZO, E.: *Optimization Methods Applied to the Preliminary Design of Innovative, Non Conventional Aircraft Configurations*. Pisa : Edizioni ETS, 2007. – ISBN 978-884672458-8
- Roskam 1989a** ROSKAM, J.: *Airplane Design. Vol. 1: Preliminary Sizing of Airplanes*. Ottawa, Kansas, 1989
- Roskam 1989b** ROSKAM, J.: *Airplane Design*. Ottawa, Kansas, 1989
- Roux 2002** ROUX, E. : Modèles Moteur: Réacteurs double flux civils et réacteurs militaires à faible taux de dilution avec PC. In : *Thèse : Pour une approche analytique de la Dynamique du Vol*, SupAéro, Toulouse, 2002. – URL: [http://www.elodieroux.com/EditionsElodieRouxBonus\\_Reports.html](http://www.elodieroux.com/EditionsElodieRouxBonus_Reports.html) (2012-02-13)
- Russel 2003** RUSSELL, S.; NORVIG, P.: *Artificial Intelligence: A Modern Approach*. New Jersey : Prentice Hall, 2003.
- Saaty 1990** SAATY, T., L.: How to Make a Decision : The Analytic Hierarchy Process. In: *European Journal of Operational Research*, Vol. 48 (1990) No. 9, pp. 9-26
- Samoyolovitch 2000** SAMOYLOVITCH, O.; STRELETS, D.: Determination of the Oswald Efficiency Factor at the Aeroplane Design Preliminary Stage. In: *Aircraft Design*, Vol. 3 (2000), pp. 167-174
- Schaufele 2000** SCHAUFELE, R.D.: *The elements of Aircraft Preliminary Design*. Santa Ana, CA : Aries, 2000

- Schiktanz 2011** SCHIKTANZ, D.; SCHOLZ, D.: Box Wing Fundamentals - An Aircraft Design Perspective. In: DGLR: *Deutscher Luft- und Raumfahrtkongress 2011 : Tagungsband - Manuskripte* (DLRK, Bremen, 27. - 29. September 2011), pp. 601-615. - ISBN: 978-3-932182-74-X. Document ID: 241353. Download: URL: <http://Airport2030.ProfScholz.de>
- Schlick 2008** SCHLICK, M.C.; DUCKWITZ, S.; GÄRTNER, T.; SCHMIDT, T.: A Complexity Measure for Concurrent Engineering Projects Based on the DSM. In: Kreimeyer, M.; Lindemann, U.; Danilovic, M. (Eds.): *Proceedings of the 10<sup>th</sup> International Design Structure Matrix Conference, DSM'08*, (Stockholm, Sweden, 11. - 12. November 2008). München : Hanser, 2008, pp. 219-230. – ISBN: 978-3-446-41825-7, Download from Digital Library of URL: <http://dsmweb.org> (2009-06-21)
- Schliemann 1999** SCHLIEMANN, K.; NIEDERKLEINE, M.: *Datenbank mit Entwurfsdaten für Passagierflugzeuge*, 1999. – URL: <http://www.fzt.haw-hamburg.de/pers/Scholz/flugzeugdaten/Datenbank.htm> (2012-08-20)
- Schmid 2009** SCHMID, M.: *Computer Aided Preliminary Design of Aircraft*. Berlin, Technical University, 2009. – URL: [http://www.luftbau.tu-berlin.de/menue/forschung/abgeschlossene\\_projekte/visual\\_capda/](http://www.luftbau.tu-berlin.de/menue/forschung/abgeschlossene_projekte/visual_capda/) (2011-09-27)
- Schmitt 1988** SCHMITT, D.: *Luftfahrttechnik, Flugzeugentwurf*, Technical University München, Chair of Aeronautical Engineering, Lecture Notes, 1988
- Schmitt 2009** SCHMITT, D.: Different Levels of Optimization in Aircraft Design. In: BUTAZZO, G.; FREDDIANI, A. (Eds.): *Variational Analysis and Aerospace Engineering, Springer Optimization and Its Applications, Vol. 33*. New York : Springer, 2009, pp. 447-459
- Scholz 1999** SCHOLZ, D.: *Flugzeugentwurf (Aircraft Design)*. Hamburg University of Applied Sciences, Department of Automotive and Aeronautical Engineering, Lecture Notes, 1999
- Scholz 2005** SCHOLZ, D.; CIORNEI, S.: Mach number, relative thickness, sweep and lift coefficient of the wing - An empirical investigation of parameters and equations, (Deutscher Luft- und Raumfahrtkongreß, Friedrichshafen, 26. - 29. September 2005). In: BRANDT, P. (Ed.): *Jahrbuch 2005*. Bonn : Deutsche Gesellschaft für Luft- und Raumfahrt, 2005. – Paper: DGLR-2005-122, ISSN 0070-4083

- Scholz 2008** SCHOLZ, D.: *Aircraft Design*. Hamburg University of Applied Sciences, Department of Automotive and Aeronautical Engineering, Short Course, 2008. – A cooperation HAW Hamburg - Airbus.
- Scholz 2009** SCHOLZ, D.; NIŤÁ, M.F.: Preliminary Sizing of Large Propeller Driven Aeroplanes. In: *Czech Aerospace Proceedings*, (2009), No. 2, pp. 41-47. – ISSN: 1211—877X. Download from: <http://paper.ProfScholz.de>
- Scholz 2012** SCHOLZ, D.: *Understanding Winglets*. Hamburg University of Applied Sciences, Department of Automotive and Aeronautical Engineering, Lecture Notes, 2012
- Schulz 2004a** SCHULZ, A.J.: *Modellbildung, -verifikation und -optimierung von Systemkopplungen des Fahrwerks bei Verkehrsflugzeugen*. Technical University Hamburg-Harburg, Student Research Project (Kleine Studienarbeit), 2004
- Schulz 2004b** SCHULZ, A.J.; CARL, U.; KOEPPEN, C.: Entwicklungs eines Prognosemodells für Masse und Leistungsbedarf von Fahrwerken im Flugzeugvorentwurf. In: DGLR: *Deutscher Luft- und Raumfahrtkongress 2004 : Jahrbuch 2004, Band I & II, Jahrbuch 2003 Band III* (DLRK, Dresden, 20. - 23. September 2004). – ISSN: 0700-4083. Document ID: JT2004-264.
- Schwefel 1981** SCHWEFEL, H.-P.: *Numerical Optimization of Computer Models*. Chicester, New York : John Wiley & Sons, 1981
- Schwefel 1997** SCHWEFEL, H.-P.: *Advantages (and Disadvantages) of Evolutionary Computation Over other Approaches*. New York : Oxford University Press, 1997
- Searles 2008** SEARLES, A.R.: *Demand for Executive/VIP Completions On The Rise*, April 2008. – URL: [http://www.aviationweek.com/aw/generic/story\\_generic.jsp?channel=om&id=news/om408\\_vip.xml](http://www.aviationweek.com/aw/generic/story_generic.jsp?channel=om&id=news/om408_vip.xml) (2009-05-01)
- Sefrioui 1996** SEFRIOUI, M.; PÉRIAUX, J.; GANASCIA, J.G.: Fast Convergence Thanks to Diversity. In: FOGEL, L.J.; ANGELINE, P.J.; BACK, T. (Eds.): *Proceedings of the 5<sup>th</sup> Annual Conference on Evolutionary Programming* (San Diego, CA, 29. February 1996). San Diego : IEEE Computer Society Press, MIT Press, 1996, pp. 313-321

- Sefrioui 2000** SEFRIOUI, M.; PÉRIAUX, J.: A Hierarchical Genetic Algorithm using Multiple Models for Optimization. In: SCHOENAUER, M.; DEB, K.; RUDOLPH, G.; YAO, X.; LUTTON, E.; MERELO, J.J.; SCHWEFEL, H.-P. (Eds.): *Parallel Problem Solving from Nature, PPSN VI*. Berlin, Heidelberg, New York : Springer, 2000, pp. 879-888
- Seyfert 2012** SEYFERT, C.; KRUMBEIN, A.: Correlation-based Transition Transport Modeling for Three-dimensional Aerodynamic Configurations. In: *AIAA: 50th AIAA Aerospace Sciences Meeting including the New Horizons Forum and Aerospace Exposition* (Nashville, Tennessee, 09. - 12. January 2012). Nashville, Tennessee : American Institute of Aeronautics and Astronautics, 2012. – Paper: AIAA-2012-0448
- Sforza 2011** SFORZA, P.M.: *Theory of Aerospace Propulsion*. Waltham, Oxford : Butterworth-Heinemann, Elsevier, 2011
- Shokhirev 2005** SHOKHIREV, N.: *Differential Evolution*, 2004-2005. – URL: <http://www.shokhirev.com/nikolai/abc/optim/dea/de.html> (2011-02-03)
- Simos 2011** SIMOS, D.: *PIANO*, 2011. – URL: <http://www.piano.aero> (2011-09-27)
- Simpson 2005** SIMPSON, C.R.: *An XML Representation for Crew Procedures*. In: – *NASA Summer Faculty Fellowship Program 2004*, Vol. 1 and 2 (2005); No. 18, pp. 1-8. – NASA/CR-2005-213690, URL: <http://ntrs.nasa.gov/search.jsp?R=20050202022> (2009-06-21)
- Simulia 2013** URL: <http://www.3ds.com/fileadmin/products/simulia/pdf/brochures/simulia-isight-brochure.pdf> (2013-02-02)
- Smith 1981** SMITH, P.M.; DEYOUNG, J.; LOVELL, W.A.; PRICE, J.E.; WASHBURN, G.F.: *A Study of High-Altitude Manned Research Aircraft Employing Strut-Braced Wings of High-Aspect Ratio*. NASA CR-159262, February, 1981.
- Smith 1997** SMITH, R.; EPPINGER, S.: Identifying Controlling Features of Engineering Design Iteration. In: *Management Science*, Vol. 43 (1997), No. 3, pp. 276-293
- Sobieski 1989** SOBIESZCZANSKY-SOBIESKI, J.: Multidisciplinary Optimization for Engineering Systems: Achievements and Potential. In: *Optimization: Methods and Applications, Possibilities and Limitations: Proceedings*

*of the International Seminar* (Bonn, Federal Republic of Germany, 07. - 08. June 1989). Berlin and New York : Springer, 1989, pp. 42-62

- Srinivas 2008** SRINIVAS, K.; PÉRIAUX, J.; LEE, D.S.; GONZALES, L.F.: Distributed Multidisciplinary Evolutionary Optimization Techniques with Uncertainties: A new Design Challenge in Aeronautics. In: *ECCOMAS – Multidisciplinary Jubilee Symposium* (Vienna, Austria, 18. - 20. February, 2008)
- Stanford 2011** STANFORD UNIVERSITY: *Propulsion Systems: Engine Model*. URL: <http://adg.stanford.edu/aa241/propulsion/engmodel.html> (2011-09-27)
- Stefanik 2006** STEFANIK, M.: *Overhead Stowage Compartments on Twin Aisle Aircraft*. University of Zilina, Faculty of Operation and Economics of Transport and Communications, Department of Air Transport, Master Thesis, 2006
- Stefanik 2007** STEFANIK, M.: *Overhead Stowage Compartments on Single Aisle Aircraft*. University of Zilina, Faculty of Operation and Economics of Transport and Communications, Department of Air Transport, Memo, 2007
- Steward 1991** STEWARD, D.: Planning and Managing the Design of Systems. In: KOCAOGLU, F.D.; NIWA, K. (Eds.): *Technology Management: The new International Language. Proceedings of Portland International Conference on Management of Engineering and Technology PICMET '91* (Portland, Oregon, 1991). Portland, 1991, pp. 189-193. – ISBN: 0-7803-0161-7
- Stinton 2001** STINTON, D.: *The Design of the Aeroplane, Second Edition*. Secaucus, NJ : Wiley-Blackwell, 2001
- Sulaeman 2001** SULAEMAN, E.: *Effect of Compressive Force on Aeroelastic Stability of a Strut-Braced Wing*. Faculty of the Virginia Polytechnic Institute and State University, Master Thesis, Doctoral Thesis, 2001
- Svoboda 2000** SVOBODA, C.: Turbofan Engine Database as a Preliminary Design Tool. In: *Aircraft Design*, Vol. 3 (2000), pp. 17-31, Elsevier Science, 2000



- Szasz 2009** SZASZ, B.: *Cabin Refurbishing Supported by Knowledge Based Engineering Software*. Hamburg University of Applied Sciences, Politehnica University Bucharest, Master Thesis, 2009
- Takahashi 1997** TAKAHASHI, S.; OBAYASHI, S.; NAKAHASHI, K.: Transonic Shock-free Wing Design with Multiobjective Genetic Algorithms. In: *Proceedings of the International Conference on Fluid Engineering* (Tokyo, Japan, 13. - 16. July 1997). Tokyo : Japan Society Mechanical Engineers, 1997
- Tétrault 2000** TÉTRAULT, P.A.: *Numerical Prediction of the Interference Drag of a Streamlined Strut Intersecting a Surface in Transonic Flow*. Blacksburg, Faculty of the Virginia Polytechnic Institute and State University, Doctoral Thesis, 2000. – URL: <http://scholar.lib.vt.edu/theses/available/etd-02112000-09420011/unrestricted/etd.pdf> (2011-03-06)
- Torenbeek 1986** TORENBEEK, E.: *Synthesis of Subsonic Airplane Design*. Delft :Delft University Press, Martinus Nijhoff publishers, 1986
- Torenbeek 1992** TORENBEEK, E.: *Development and Application of a Comprehensive, Design-sensitive Weight Prediction Method for Wing Structures of Transport Category Aircraft*. Delft University of Technology, Faculty of Aerospace Engineering, Report LR-693, 1992
- Trahmer 2008** TRAHMER B.: Landing Gear Conceptual Design and Integration. In: *Aircraft Design*. Hamburg University of Applied Sciences, Department of Automotive and Aeronautical Engineering, Short Course, 2008
- Transport 2010** TRANSPORT CANADA: *Deep Vein Thrombosis*. – URL: <http://www.tc.gc.ca/eng/civilaviation/standards/commerce-cabinsafety-dvt-1086.htm> (2010-05-31)
- Turriziani 1980** TURRIZIANI, R.V.; LOVELL, W.A.; MARTIN, G.L.; PRICE, J.E.; SWANSON, E.E.; WASHBURN, G.F.: *Preliminary Design Characteristics of a Subsonic Business Jet Concept Employing an Aspect Ratio 25 Strut-Braced Wing*. NASA CR-159361, October 1980.
- Van der Aalst 2003** VAN DER AALST, M. P. Wil: *Patterns and XPD L: A Critical Evaluation of the XML Process Definition Language*. – Department of

Technology Management Eindhoven University of Technology, Netherlands, 2003. – URL: <http://is.tm.tue.nl/research/patterns/download/ce-xpdl.pdf> (2009-06-21)

- Vanderplaats 1984** VANDERPLAATS, G.N.: *Numerical Optimization Techniques for Engineering Design*. New York : McGraw-Hill, 1984
- Verstraete 2008** VERSTRAETE, T.; VAN DEN BRAEMBUSSCHE, R.A.: Multidisciplinary Optimization of Turbomachinery Components Including Heat Transfer and Stress Predictions. In: PÉRIAUX, J.; DECONINCK, H. (Eds.): *Introduction to Optimization Methods for Multidisciplinary Design in Aeronautics and Turbomachinery (von Karman Institute for Fluid Dynamics, Lecture Series 2008-07)*. Belgium : VKI, 2008. – ISBN 978-2-930389-86-9
- Waeterschoot 2012** WAETERSCHOOT, M.: *The Effect of Variations of the Height to Span Ratio of Box Wing Aircraft on Induced Drag and the Spanwise Distribution*. Hamburg University of Applied Sciences, Department of Automotive and Aeronautical Engineering, Project, 2012
- Whitcomb 1976** WHITCOMB R.T.: *A Design Approach and Selected Wind-Tunnel Results at High Subsonic Speeds for Wing-Tip Mounted Winglets*, NASA Technical Note D-8260. Washington D.C. : NASA, July 1976
- Whitney 2003** WHITNEY, E.J.: *A Modern Evolutionary Technique for Design and Optimization in Aeronautics*. Sydney, University of Sydney, Doctoral Thesis, 2003
- Wiki 2012** URL: [http://en.wikipedia.org/wiki/Boeing\\_707](http://en.wikipedia.org/wiki/Boeing_707) (2012-08-20)
- Zhong 2008** ZHONG, P.; SONG, J.; LU, M.: DSM Based Process Analysis for Concurrent Product Development and Its Implementation. In: SHEN, W.; et al. (Eds.): *Proceedings of the 12th International Conference on Computer Supported Cooperative Work in Design, CSCWD 2008* (Xi'an, China, 16. - 18. April 2008), Vol. 2 (2008). Piscataway, NJ : IEEE Press, 2008, pp. 619-624. – ISBN: 978-1-4244-1650-9, Download from Digital Library of URL: <http://dsmweb.org> (2009-06-21)



# Appendix A Database of Aircraft and Aircraft Data

The following Tables summarize the aircraft used in the study of the Oswald efficiency factor (Sections 2.2.1 and 2.2.2) and their main characteristics, required for calculations. For all these aircraft the Oswald factor was known from the following literature sources: **Roskam 1989b**, **Jenkinson 1999**, **Samoylovitch 2000**, **Roux 2002**, **Airbus 2011**, **Lambert 2001**, **Lambert 1997**, **MPC 75**, **Schliemann 1999**, **Boeing 2012**, **Wiki 2012**, **Flug 2012**.

**Table A.1** Amount of aircraft used to evaluate existing estimation methods for the Oswald factor

Type	Amount	Total in Group	Aircraft Size	Group Name
General aviation (GA)	9	10	small	GA aircraft
GA aircraft, 2-engines	1		prop	
Propeller aircraft				
2 engines	4	6	medium	propeller aircraft
4 engines	1		prop	
Medium Bomber	1			
Regional jet	2	4	medium	business jet
Business jet	2		jet	
Jet aircraft	11	13	large jet	jet airliner
Military transporter	1			
Long range bomber	1			
Fighter	6	6	fighter	fighter

**Table A.2** List of aircraft and aircraft characteristics

Aircraft / Aircraft category	Type	$\lambda$	$A$	$\varphi_{25}$	$d_F$	$b$	$d_F / b$	$M_{CR}$	$M_e$	$e$
Jet airliner										
A 300-600	Twin jet airliner	0.293	7.73	28	-	-	-	0.78	0.78	0.749
A 319	Twin jet airliner	0.240	9.40	25	-	-	-	0.78	0.78	0.753
A320	Twin jet airliner	0.24	9.50	25	4.04	34.1	0.118	0.76	0.76	0.783
B 737-800	Twin jet airliner	0.219	9.45	25	3.88	34.32	0.113	0.78	0.78	0.660
MPC 75	Twin jet airliner	0.260	9.6	23.5	3.45	29.72	0.116	0.77	0.77	0.553
B767-300	Twin jet airliner	0.306	7.99	31.5	-	-	-	0.80	0.80	0.670
MD 90-30	Twin jet airliner	0.193	9.62	24.5	-	-	-	0.76	0.76	0.811*
B 707-320B	Twin jet airliner	0.288	7.05	36	-	-	-	0.82	0.82	0.700
DC 9-30	Twin jet airliner	0.206	6.80	24	-	-	-	0.75	0.30	0.810
TU 154M	Tri-jet airliner	0.267	7.00	35	-	-	-	0.73	0.73	0.665
C 17A Globemaster III	Strategic transport	0.262	7.20	25	-	-	-	0.75	0.30	0.870
B 52-A	Long range bomber	0.044	8.60	36	-	-	-	0.99	0.30	0.924*
A 340-300	Four jet airliner	0.235	9.26	30	-	-	-	0.82	0.82	0.770
Propeller aircraft										
Douglas DC3	Twin propeller aircraft	0.284	9.17	8	3.13	29.98	0.104	0.22	0.30	0.750
Gulfstream GI	Twin propeller	0.374	10.1	4	2.56	23.93	0.106	0.50	0.30	0.780

Saab SF 340B	aircraft Twin propeller aircraft	0.441	11.0	3.5	2.35	21.44	0.109	0.50	0.30	0.800
Boeing 247D	Twin propeller aircraft	0.529	6.55	2	1.95	22.66	0.086	0.26	0.30	0.750
Martin B26F Marauda	Medium bomber twin propeller	0.326	7.67	4	2.40	21.65	0.110	0.31	0.30	0.750
Ilyushin IL 18	Four engines propeller aircraft	0.407	9.99	2	3.60	37.4	0.096	0.56	0.30	0.800
<b>Business jet</b>										
Fokker F28-2000	Regional jet, 2 engines	0.262	7.27	17	3.10	23.58	0.131	0.68	0.30	0.818
Yakovlev Yak 40	Regional jet, 3 engines	0.446	8.93	1	2.40	25	0.096	0.49	0.30	0.820
Learjet 35	Business jet	0.566	5.73	13	1.15	12.04	0.095	0.70	0.30	0.827
Learjet M25	Business jet	0.571	5.00	8.7	1.7	10.84	0.156	0.81	0.30	0.820
<b>General aviation aircraft</b>										
Beech 35	GA aircraft	0.562	6.21	2	1.37	10.21	0.134	0.21	0.21	0.820
Beechcraft D 17D	GA aircraft	1	6.84	0	1.16	9.75	0.119	0.27	0.27	0.760
Cessna 177 Cardinal RG	GA aircraft	0.703	7.23	0	1.23	10.82	0.113	0.19	0.19	0.630
Cessna 150	GA aircraft	0.692	7.00	0	1.3	10.21	0.127	0.16	0.16	0.770
Cessna 180	GA aircraft	0.669	7.5	0	1.4	10.98	0.127	0.22	0.22	0.750
Cessna 182S	GA aircraft	0.669	7.5	0	1.4	10.98	0.127	0.22	0.22	0.840
PA 28 Cherokee	GA aircraft	0.669	7.21	0	1.18	10.67	0.110	0.17	0.17	0.760
Cessna 172 Skyhawk	GA aircraft	0.709	7.45	0	1.27	10.97	0.115	0.19	0.19	0.750
Piper J3 Cub	GA aircraft	1	6.96	0	0.84	10.74	0.078	0.10	0.10	0.750
Cessna 310	GA aircraft, 2 engines	0.693	7.62	0	1.5	11.25	0.133	0.27	0.27	0.730
<b>Fighter</b>										
McDonnell F4 Phantom	Fighter (interceptor, bomber)	0.199	2.78	44	-	-	-	0.88	0.30	0.700
Lockheed Martin F22 Raptor	Fighter (stealth air superiority)	0.112	2.36	30	-	-	-	1.58	0.30	0.820
Sukhoi Su 27	Fighter (air superiority)	0.351	3.49	37	-	-	-	2.35	0.30	0.710
Mikoyan-Gurevich MIG 29	Fighter (multirole)	0.210	3.42	35	-	-	-	2.30	0.30	0.850
Mikoyan-Gurevich MIG AT	Fighter (advanced jet trainer)	0.298	5.83	7	-	-	-	0.85	0.30	0.610
Douglas D558-2 Skyrocket	Experimental high speed research	0.558	6.70	35	-	-	-	1.01	0.30	0.820
* questionable value										



## Analytic Hierarchy Process - AHP

Please fill in the blanks above the diagonal with points from 0 to 10, depending on the degree of importance of each attribute. Use the following table as reference.

6 to 10 points	The attribute is <i>more important</i> than the attribute to which it is compared to.
5 points	The attribute is <i>equally important</i> with the attribute to which is compared to.
0 to 4 points	The attribute is <i>less important</i> than the attribute to which is compared to.

For instance, in order to fill in line 5, the respective element in column A (seat pitch) is compared to all the elements in row B.

*Example : comparisson of attribute 5 (seat pitch) to attribute 8 (aisle width)*

*Seat pitch is more important than aisle width and receives 7 out of 10 points.*

*Aisle width is less important than seat pitch, so it gets the remaining 3 points (automatically).*

A		B															
	↑	1	2	3	4	5	6	7	8	9	10	11	12	13	14	15	16
Landing field length	1																
Take-off field length	2	10															
Relative landing weight (m <sub>ML</sub> /m <sub>MTO</sub> )	3	10	10														
Cruise speed	4	10	10	10													
Seat pitch	5	10	10	10	10				7								
Seat width	6	10	10	10	10	10											
Armrest width	7	10	10	10	10	10	10										
Aisle width	8	10	10	10	10	3	10	10									
Aisle height	9	10	10	10	10	10	10	10	10								
Overhead bin volume per pax	10	10	10	10	10	10	10	10	10	10							
Aircraft gust sensibility	11	10	10	10	10	10	10	10	10	10	10						
Sidewall clearance	12	10	10	10	10	10	10	10	10	10	10	10					
Number of "excuse-me" seats	13	10	10	10	10	10	10	10	10	10	10	10	10				
Containerized cargo (yes/no)	14	10	10	10	10	10	10	10	10	10	10	10	10	10			
Accessibility factor	15	10	10	10	10	10	10	10	10	10	10	10	10	10	10		
Cargo compartment height	16	10	10	10	10	10	10	10	10	10	10	10	10	10	10	10	

# Appendix C      The Elements of the Process Chain for Cabin Conversions

In order to identify each process within the system, they need to be labeled. The chosen coding system will be used by the Data Management System of the Design Organization, which will allow users to control and administrate the data produced / required by every process. A simple coding system used in this work is illustrated below.

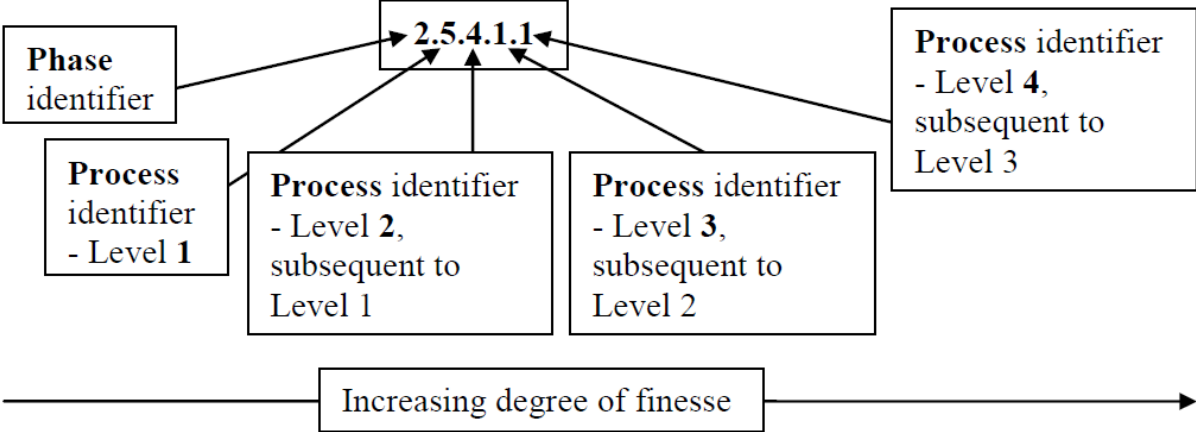

**Fig. C.1**      Coding system used for the process illustration

Figures C.2 to C.8 list the process chain. Marked in red are those processes that are certification related.



1. OFFER	1.1	Receive request
	1.2	Assign Offer Leader*
	1.3	Analyze request
	1.4	Contact customer and set first meeting
	1.5	On the first meeting: initiate discussions and negotiations
	+ 1.6	Write CRTS (Customer Request Technical Sheet) in which:
		1.6.1 Preliminary describe the technical implications
		1.6.2 Make estimations (based on experience) regarding design effort, time, costs
	1.7	Conceive preliminary solutions (for discussing it with the customer)
	1.8	Create preliminary representation of the solutions found (with tools which fit the marketing function, i.e. Pacelab Cabin, Aircraft Scanner)
	+ 1.9	Make feasibility study
		1.9.1 Analyse estimated results
		1.9.2 Identify required resources
		1.9.3 Estimate profit
	1.10	Decide if go ahead; if yes, then:
	1.11	Get signed agreement within a second meeting
	+ 1.12	Write DTS (Detailed Technical Sheet)
		1.12.1 Estimate the size of the work package
		1.12.2 Identify involved technical fields
	+ 1.12.3	Identify certification basis
		1.12.3.1 Identify certification implications
		1.12.3.2 Set preliminary certification requirements
		1.12.4 Identify resources for performing the work
		1.12.5 Make estimations regarding design effort, time, costs
	1.13	Identify suitable project leader and personnel
	1.14	Confront DTS with CR
	1.15	Make adjustments
	1.16	Send results further down (concept) in order for the work to be initiated

**Fig. C.2** Process illustration: Offer Phase

2. CONCEPT	2.1	Analyze customer requirements
	2.2	Perform aircraft inspection
	2.3	Write document describing diagnosis
	2.4	Identify the technical fields involved in the design process*
+	2.5	Initiate team organization for- and division of responsibilities between
	2.5.1	Engineering
	2.5.2	Design
	2.5.3	Certification (OoA)
	2.5.4	Quality Assurance
	+	2.5.4.1 for each technical field
		2.5.4.1.1 Avionics & Equipment
		2.5.4.1.2 Environmental Systems
		2.5.4.1.3 Electrical Systems
		2.5.4.1.4 Cabin Interior
		2.5.4.1.5 Monuments and other Equipment
		2.5.4.1.6 Emergency & Safety Equipment
+	2.6	Plan the design & engineering process (by the Engineering and Design Office)
	2.6.1	Assign teams for each technical field
	2.6.2	Assign tools to work with
	2.6.3	Choose QM strategy (! Before defining processes)
	2.6.4	Conceive the process (what) chain of the work flow
	2.6.5	Conceive the procedures (how) to be followed
	2.6.6	Make optimization studies
+	2.7	Plan the certification process (by Office of Airworthiness)
	2.7.1	Contact EASA and TC Holder
	2.7.2	Identify certification basis
	2.7.3	Analyze certification requirements
	2.7.4	Transform Certification Requirements into technical rules
	2.7.5	Identify means of testing and showing of compliance (MOC's)
	2.7.6	Set classification procedures for minor and major changes according to EASA (AMC&GM Part 21)
	2.7.7	Send application for STC to EASA
	2.7.8	Send application for major changes to EASA
	2.7.9	Identify responsible persons for approving minor changes
	2.7.10	Identify responsible persons for creating the documentation to be sent to EASA for approval (for major changes)
	2.7.11	Verify the consistency of the certification basis
	2.8	Identify required resources and tools
	2.9	Decide if it's necessary to involve subcontractors
	2.10	Conceive preliminary models
	2.11	Consult/report to customer
	2.12	Verify the fulfilling of customer requirements
	2.12	Validate concept (regarding all aspects: work flow, work procedures, design...)

**Fig. C.3** Process illustration: Concept Phase

3. DEFINITION	3.1	Define the QM strategy and follow it when detailing the processes
	+ 3.2	Organize work flow (who & what does)/Create Work Breakdown Structure
		3.2.1 Identify and assign personnel
		3.2.2 Identify tasks
		3.2.3 Define work procedures, corresponding to the type of work
	+ 3.2.4	Identify types of documents and document flow
		+ 3.2.4.1 to be produced by Design Engineers:
		3.2.4.1.1 Engineering Orders
		3.2.4.1.2 Instructions for installation and assembly
		3.2.4.1.3 Appendices to CMM (Component Maintenance Manual) and AMM (Aircraft Maintenance Manual)
		+ 3.2.4.2 to be produced by Airworthiness Engineers:
		3.2.4.2.1 Documents for showing compliance
		3.2.4.2.2 Approval documents
	3.3	Identify parallel processes and prescribe the parallel process performing
	3.4	Schedule work
	+ 3.5	Define work procedures (how to do it) for
		3.5.1 Certification
		3.5.2 Monitoring
		3.5.3 Design
		3.5.4 Quality Assurance
		3.5.5 Relation with subcontractors
	+ 3.6	Define the design concept
		+ 3.6.1 Perform design studies for each technical field
		3.6.1.1 Identify interferences between technical fields
		3.6.1.2 Identify possible conflicts between technical fields
		3.6.2 Identify the feasible choice
		3.6.3 Validate design concept
	+ 3.7	Prepare Certification
		3.7.1 Define Test and Verification Methods, according to the MOC's and specific for the type of design
		3.7.2 Create compliance check lists

**Fig. C.4** Process illustration: Definition Phase

4. DESIGN	4.1	Receive and understand design assignments from responsible person (Chief of Design)
	+ 4.2	Analyze and understand constraints specific to the design:
		4.2.1 Certification constraints
		4.2.2 Customer constraints
		4.2.3 Design limits
	4.3	Optimize tool selection (already indicated in concept phase, but also in concept phase)
	+ 4.4	Perform design, including:
		4.4.1 Perform simulations
		4.4.2 Perform 2D and 3D representations
	+ 4.5	Perform design analysis and verification (Design Verification Engineer-DVE)
		4.5.1 Analyze the electrical and mechanical loads
		4.5.2 Analyze interference with structure
		4.5.3 Define tolerances
		4.5.4 Perform assembly analysis
		4.5.5 Identify clashes
		4.5.6 In case of clashes, propose feasible solutions
		4.5.7 Choose and apply final solution
	+ 4.6	Perform design analysis and verification (Compliance Verification Engineer-CVE)
		4.6.1 Confront results of the DVE with the prescriptions from MOC's
		4.6.2 Report non-compliance back to the DVE
	4.7	Choose and apply final solution (after receiving feedback from CVE)
	4.8	Produce part lists
	4.8	Produce corresponding documentation (as described in the definition phase)
	4.10	Send documentation to get approval (to the OoA)

**Fig. C.5** Process illustration: Design Phase

5. CERTIFICATION	5.1	Receive documentation to be approved
	+ 5.2	Perform test and compliance verification procedures according to MOC
		5.2.1 for each component
		5.2.2 for the assembled components
	5.3	Create corresponding approval reports
	5.4	Send corresponding documentation (e.g. test results) to EASA (for major changes)
	5.5	Approve minor changes under the DO privileges
	5.6	Receive STC
	5.7	Receive approval for major changes
	5.8	Prepare instructions for Continued Airworthiness

**Fig. C.6** Process illustration: Certification Phase

6. HAND OVER	6.1	Collect technical documentation and approval documents
	6.2	Collect assembly instructions
	6.3	Prepare the documentation in the form required by the customer
	6.4	Deliver results
	6.5	Assign assistance team available upon customer request
	6.6	Register Lessons Learned
	6.7	Archive all data
	6.8	Perform final cost evaluation

**Fig. C.7** Process illustration: Hand-Over Phase

7. ADJUSTMENT	7.1	Get functioning feedback from every engineering department
	7.2	Analyze overall functioning of the DO
	7.3	Detect points of improvement
	7.4	Propose optimized solutions
	7.5	Create functioning reports
	7.6	Send reports to management
	7.7	Receive feedback from management
	7.8	Prepare updated procedures, as it is required, after receiving instructions from management

**Fig. C.8** Process illustration: Adjustment Phase



# Appendix D Market Forecast Methodology for Cabin Modifications

*Passenger Aircraft.* The method used for the computation is to scan each sheet and each row of the database while looking for specific characteristics. For each aircraft:

- the table sheets are scanned,
- the characteristics of the aircraft are filtered,
- the scenario parameters are scanned and the scenario is identified and written in the database,
- the number of modifications is computed and written in the database.

The date at which the next cabin modification is predicted to occur is calculated with relation (D.1) by adding the frequency duration,  $frequency_{scenario}$  and the scenario duration,  $duration_{scenario}$  to the date at which the last retrofit program ended. Equation (D.1) is executed until the condition (D.2) is no longer valid. It is checked if the date of the computed retrofit program ( $date_{modification}$ ) is not exceeding the deadline of the forecast (01/07/2029) or the second deadline, corresponding to the aircraft age ( $age_{scenario\_limit}$ ) for which the refurbishing is no longer planned by the operator. This second deadline is calculated thanks to the date of the aircraft first delivery ( $date_{aircraft\_delivery}$ ).

$$date_{modification} = date_{previous\_modification} + frequency_{scenario} + duration_{scenario} \quad (D.1)$$

$$date_{modification} < \max(01/07/2009, date_{aircraft\_delivery} + age_{scenario\_limit}) \quad (D.2)$$

The number of modifications,  $n$  is given by the number of loop executions,  $n_{loop}$ :

$$n = n_{loop} + 1 \quad (D.3)$$

For aircraft on operating lease, the duration of the retrofit program ( $duration_{scenario}$ ) is the duration of one aircraft refurbishing,  $duration_{modification}$ . It is considered that these aircraft do not take part into a refurbishing program (like wide-bodies and narrow-bodies owned by the operator), but they need to be reconfigured just after the aircraft lease termination.

$$duration_{scenario} = duration_{modification} \quad (D.4)$$

For aircraft owned by an operator, a retrofit program is usually undertaken by the airline for the whole fleet. Therefore the volume of the fleet ( $volume_{fleet}$ ) has to be taken into account. Along with the equivalent duration of one aircraft refurbishing ( $duration_{equivalent}$ ), it helps to determine the duration of the whole retrofit program for the fleet ( $duration_{scenario}$ ). The

$duration_{scenario}$  variable does not correspond to the real duration of one aircraft refurbishing, but determines the real time between two refurbishing programs for the same aircraft.

$$duration_{scenario} = duration_{total} = duration_{equivalent} \cdot volume_{fleet} \quad (D.5)$$

*Freighter Aircraft.* Only those aircraft on commercial use, which have reached a specific age and could be further involved in a pax-to-freighter conversion, are considered in the database. Additional input information is represented by the Boeing forecast<sup>27</sup>, which predicts a number of 3500 airplanes required. According to Boeing, 75 % of this amount will be represented by pax-to-freighter conversions (Equation D.6). In order to get the amount of freighter conversions in a specific world region,  $n_{freighter\_conversion}^{world\_region}$ , the Equation (D.7) is used, where  $p_{freighter\_fleet}^{world\_region}$  is the proportion of the freighter fleet in this specific region:

$$n_{freighter\_conversion} = n_{additional\_airplanes} \cdot P_{freighter\_conversion} \quad (D.6)$$

$$n_{freighter\_conversion}^{world\_region} = n_{freighter\_conversion} \cdot P_{freighter\_fleet}^{world\_region} \quad (D.7)$$

*Executive Jets.* No database with enough detailed information has been found about the executive jets fleet world distribution, neither about the current fleet volume. Therefore only the fleet volume for the 2009-2029 is used, based on the data gathered in Section 10.6.

For each aircraft, the number of VIP completions is computed in the following way: First, the duration of the period,  $duration_{scenario\_period}$ , within which VIP completions should be undertaken, is computed.

$$duration_{scenario\_period} = age_{scenario\_limit} \quad (D.8)$$

where  $age_{scenario\_limit}$  represents the limit at which VIP completions are not undertaken anymore.

Within this time, the number of VIP completions,  $n_{aircraft}$ , which could be undertaken for one aircraft, are computed.

$$n_{aircraft} = \text{int} \left[ \frac{duration_{scenario\_period}}{(duration_{scenario} + frequency_{scenario})} \right] \quad (D.9)$$

Finally, the total number of VIP completions,  $n$ , for the entire business aircraft forecasted fleet, is computed.

$$n = n_{aircraft} \cdot volume_{fleet} \quad (D.10)$$

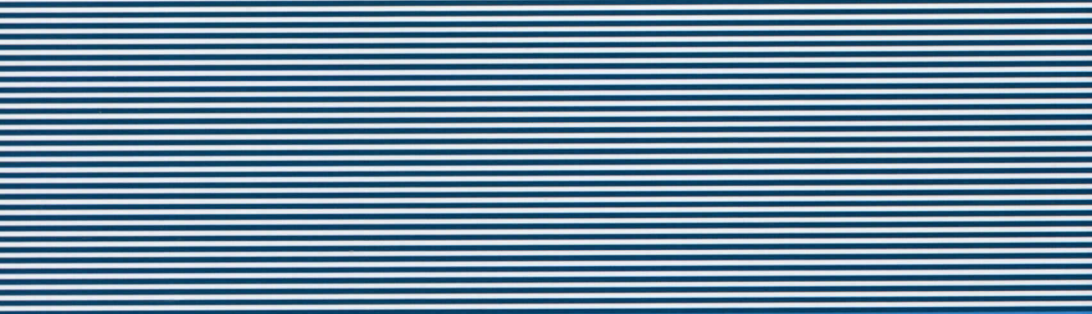

ISBN 978-3-8439-1163-4



9 783843 911634