

AIRCRAFT DESIGN AND SYSTEMS GROUP (AERO)

Ethics in the Aviation Industry – Flying Off Course

Dieter Scholz

Hamburg University of Applied Sciences

SARC Friday Club

Online / Linköping University (LiU), 04.11.2022

<https://doi.org/10.5281/zenodo.7296524>

<https://purl.org/aero/PRE2022-11-04>

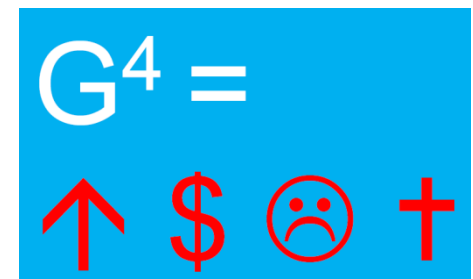
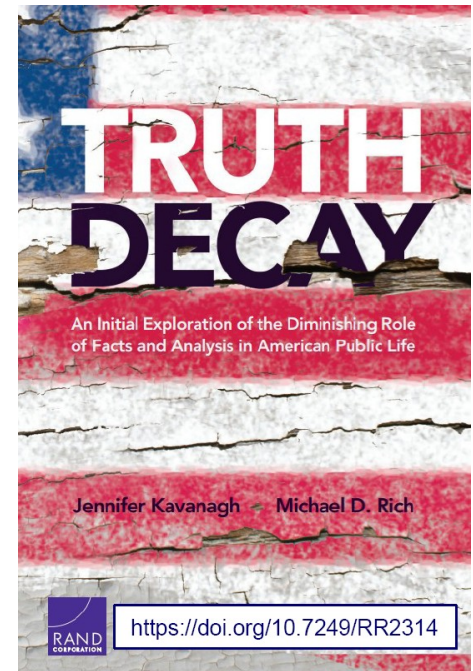

Ethics in the Aviation Industry – Flying Off Course

Abstract

Truth decay and compromised ethical behavior can be observed when looking back into the history of the aviation industry. The author has presented since 2012 about related questionable views and behavior. In this presentation he compiles the "best" of his slides into one lecture that tries to give an overview of the problem at hand. Commercial aviation provides one of the strongest examples of Jevons Paradox, nevertheless the aviation industry keeps praising efficiency gains as the way to safe fuel and emissions on a global scale. Questionable goal setting with respect to aviation emissions started as early as 2000. Inside the aircraft another problem exists: contaminated aircraft cabin air. Here, the aviation industry rather fights claims of victims in court instead of working on a technical solution. The idea of massive use of air taxis is as old as 1899, but has still not come. Eventually it will most probably be a polluting means of transportation for the super-rich. Battery electric aviation has a clear range limit. Proposals that deny this fact are green washing. Grid-connected electric mobility operates successfully on tracks e.g. as high-speed trains. Claims for a large number of propellers may have been made without looking at certification rules and geometry. The year 2020 came. Those waiting to see a difference in aviation (massive CO₂-compensation by the industry) to fulfill at last aviation's goal setting promise of Carbon Neutral Growth (CNG) saw – nothing. However, the Corona pandemic came after two month into the year 2020. Most aircraft rested on the ground. Subsequently, passengers saw more legends than truth about cabin ventilation. The legends were distributed by the aviation industry in an effort to retain at least a minimum of revenues. IATA turned out to be the biggest liar among all. Airbus chief engineer Jean-Brice Dumont was given the new title "guru" and explained cabin ventilation on Facebook. Emirates presented two highly protected technicians mounting a new and clean HEPA filter on an A380. Still in the same year the next legend was presented by Airbus: Aircraft burning hydrogen in jet engines would produce "zero emissions". In contrast to science, this would mean no NO_x and no contrails. After the pandemic, industry could not wait to see air traffic reaching again 2019 levels and old growth figures. It was still not understood that instead a reduction in air traffic would be necessary to reach proclaimed goals. It was also not understood that regenerative energy would need to be used first to substitute coal power plants and that massive aviation regenerative electricity demands for LH₂ and SAF had no chance to be addressed by society. Aviation would need to produce its green energy itself. Time scales slipped or turned out to have been lies in the first place. 2021 was the year to look back at the "money burning" A380 project. This reminded us that Airbus lied already 20 years ago when demanding a runway extension in Hamburg-Finkenwerder for the A380. The extension was not necessary, but was built (from public money) anyway and against much protest from local population and their precise engineering/aviation arguments. Aviation ethics can be summed up under: "G⁴", which stands for "Continuous Growth to increase Gain to satisfy shareholders expectations can lead to Greed and to an ever more ruthless industry behavior accumulating Guilt in the end." Some aviation organizations seem not to be willing to abide by the law, even if enforced and with consequences leading to the end of company existence. Boeing gambled with saving a second angel-of-attack sensor on the B737 MAX, resulting in two crashes and 346 people dying. Airbus paid 3.6 Billion Euro penalty due to bribery. The aviation industry is far from abidance by the law and even further away from taking up the code of a respectable / honorable businessman. The list of unethical issues in the aviation industry is long.



Contents

- **Eco-Efficiency in Aviation – Flying Off Course?**
- **Aircraft Cabin Air Contamination – Health & Flight Safety Implications** (Susan Michaelis)
- **Aircraft Cabin Air and Engine Oil – An Engineering Update**
- **Limits to Principles of Electric Flight**
- **Aircraft Cabin Ventilation in the Corona Pandemic – Legend and Truth**
- **Review of CO2 Reduction Promises and Visions for 2020 in Aviation**
- **Design of Hydrogen Passenger Aircraft – How much "Zero-Emission" is Possible?**
- **Zero Emission – The New Credo in Civil Aviation**
- **Social Evaluation of Aircraft Projects: Example Airbus A380**
- **Aviation Ethics – Growth, Gain, Greed, and Guilt**

The title page of each individual presentation links to its [archived full version](#).

For [references](#), please look into the full version of each presentation.

SARC – the Swedish Aerospace Research Center (<https://sarc.center>)

*Encouraging national coordination and
alignment of academic research in aerospace*



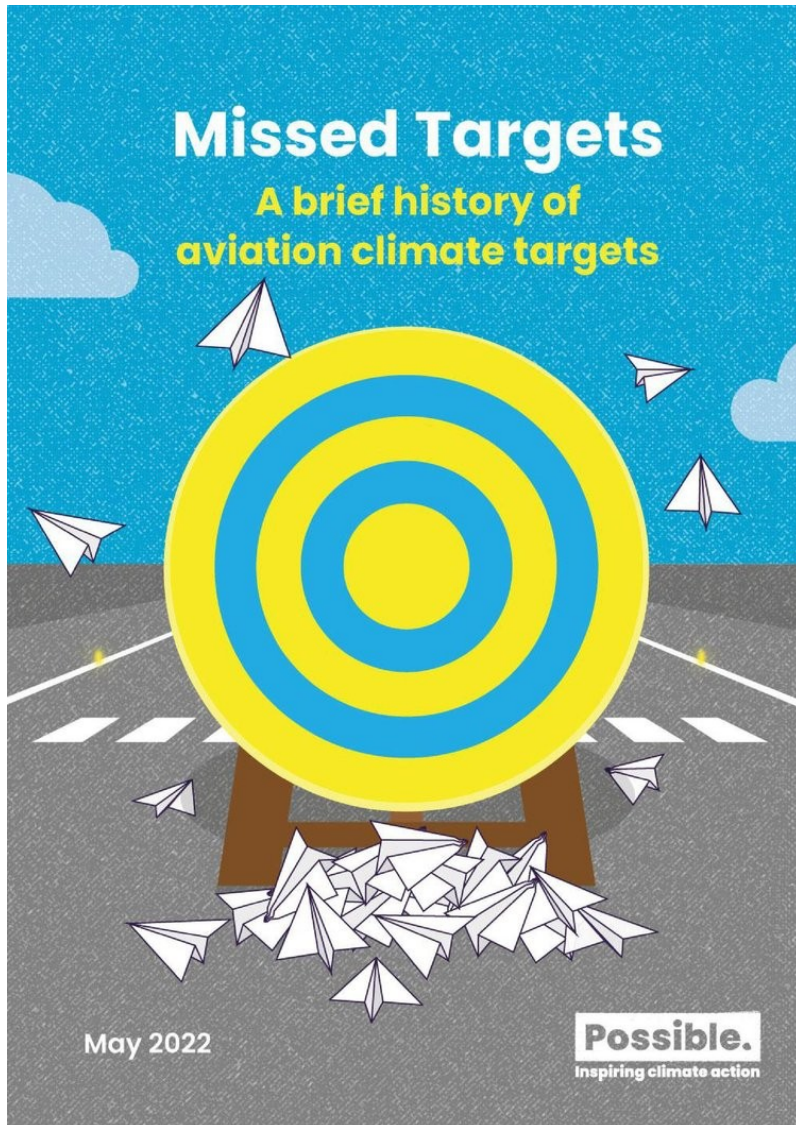

"This report assessed every public climate target which the international aviation industry set itself since 2000.

We found that all but one of over 50 separate climate targets has either been missed, abandoned or simply forgotten about.

Overall, the industry's attempts to regulate its emissions and set its own targets suffered from a combination of unclear definitions, shifting goalposts, inconsistent reporting, a complete lack of public accountability and, in some cases, [goals] being quietly dropped altogether."

URL: <https://www.wearpossible.org/our-reports-1/missed-target-a-brief-history-of-aviation-climate-targets>

Archived: <https://perma.cc/4SYC-UL93>



Hochschule für Angewandte Wissenschaften Hamburg
Hamburg University of Applied Sciences

AERO – AIRCRAFT DESIGN AND SYSTEMS GROUP

Eco-Efficiency in Aviation – Flying Off Course?

Dieter Scholz

Hamburg University of Applied Sciences

<https://doi.org/10.5281/zenodo.4067014>

Deutscher Luft- und Raumfahrtkongress 2012

German Aerospace Congress 2012

Berlin, Germany, 10.-12.09.2012

resilience

Introduction

Definition: **Eco-efficiency** (Ökoeffizienz)

*Eco-efficiency is based on the concept of creating more goods and services while using fewer resources and **creating less waste and pollution**.*

World Business Council for Sustainable Development (WBCSD): "Changing Course", 1992

The term has become synonymous with a management philosophy geared towards *sustainability*.

The **eco-efficiency strategy** has the following characteristics:

- Technological **innovation** the main solution
- **Business** as the principal actor of transformation
- Trust in **markets** (if they are functioning well)
- "cradle-to-cradle" (essentially **waste free**) growth is conducive.

Boulanger, P.M. (2010) "Three strategies for sustainable consumption". S.A.P.I.EN.S. 3 (2)

Introduction

Definition: **Sustainability** (Nachhaltigkeit)

*A sustainable development is a development that meets the needs of the present **without compromising the ability of future generations to meet their own needs.***

United Nations General Assembly: "Report of the World Commission on Environment and Development: Our Common Future; Transmitted to the General Assembly as an Annex to document A/42/427 – Development and International Co-operation: Environment; Our Common Future, Chapter 2: Towards Sustainable Development; Paragraph 1". March 20, 1987. - <http://www.un-documents.net/ocf-02.htm>

Since the 1980s sustainability has been used especially in the sense of human sustainability on planet earth.

Translation: **off course = vom Kurs abgewichen**

Introduction

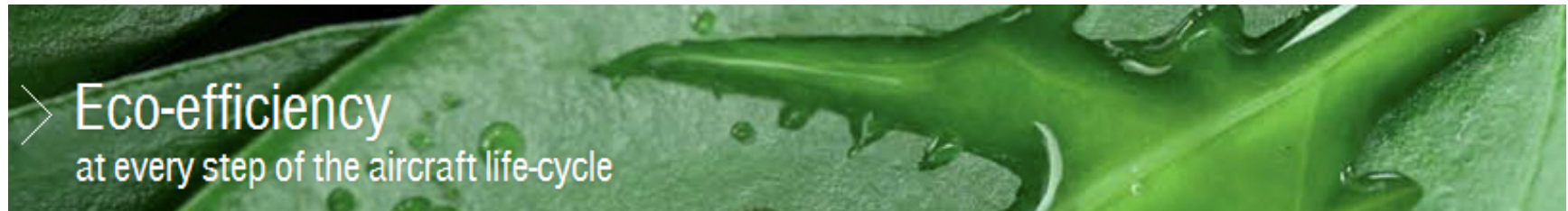

Airbus develops **eco-efficient solutions** at every stage of the aircraft life-cycle:

- Optimized **performance** by design
- Dissemination of best environment practices within the **supply chain**
- Greener **manufacturing** processes
- Supporting efficient aircraft **operations**
- **Recycling** and re-use at end-of-life

In addition, the company assumes a leading role in improving the overall air transport system by

- contributing to the modernization of Air Traffic Management (**ATM**) and
- promoting low-emission **alternative fuels**.

Introduction



Introduction



some
have
a different
view ...

Growth and Goals for Innovation

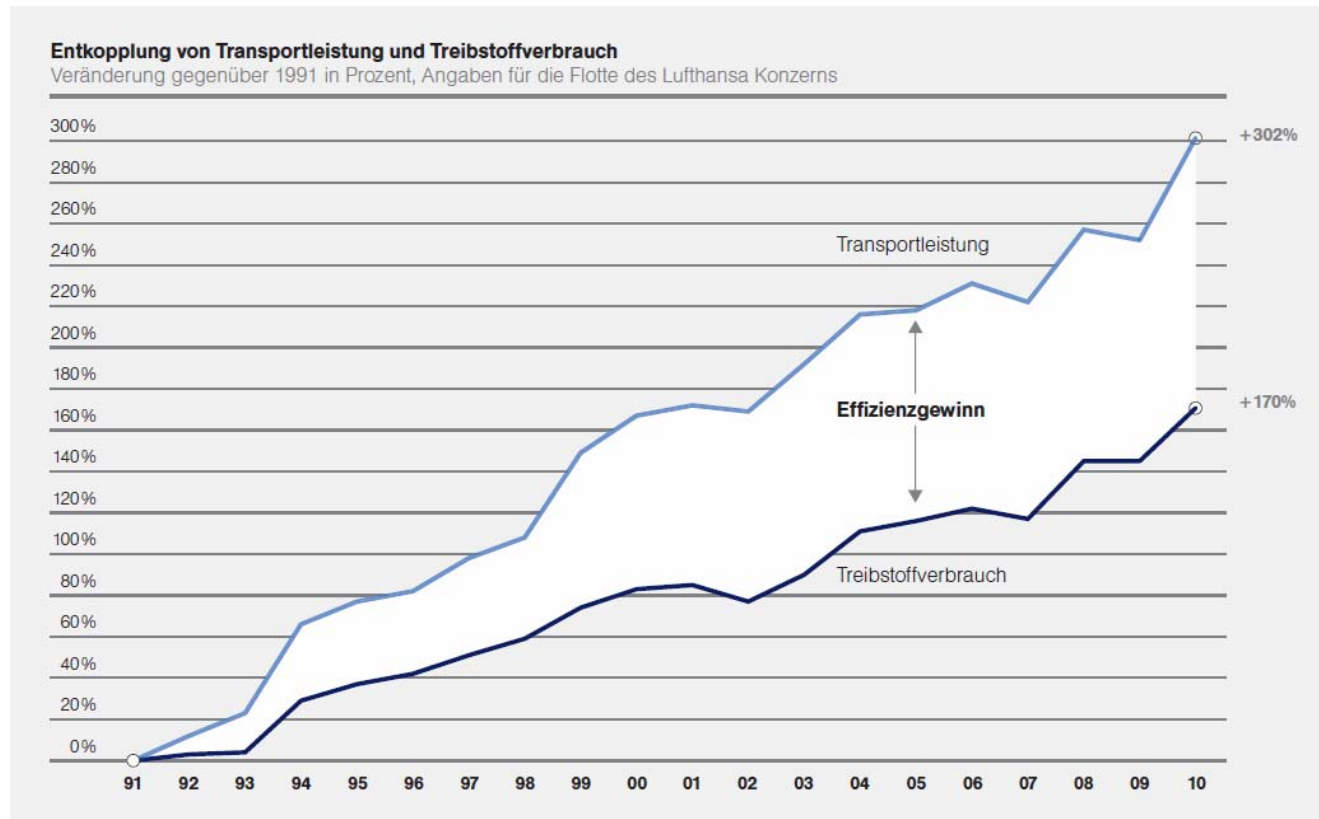

Fig.: Growth of Transport Capacity and Fuel Consumption at Lufthansa

Lufthansa: Balance – Das wichtigste zum Thema Nachhaltigkeit im Lufthansakonzert. 2011

Growth and Goals for Innovation

An Old IATA Goal for the Reduction of Fuel Burn or CO2

[Home](#) » [Pressroom](#) » [Press Releases](#) » [IATA Calls for a Zero Emissions Future](#)

No.: 21

Date: 4 June 2007



IATA Calls for a Zero Emissions Future

VANCOUVER - The International Air Transport Association (IATA) issued four challenges to drive the air transport industry towards its vision of zero emissions.

“The environmental track record of the industry is good: over the last four decades we have reduced noise by 75%, eliminated soot and improved fuel efficiency by 70%. And the billions being invested in new aircraft will make our fleet 25% more fuel efficient by 2020. This will limit the growth of our carbon footprint from today’s 2% to 3% in 2050,” said Giovanni Bisignani, IATA Director General and CEO.

“But a growing carbon footprint is no longer politically acceptable—for any industry. Climate change will limit our future unless we change our approach from technical to strategic. Air transport must aim to become an industry that does not pollute—**zero emissions**” said Bisignani.

Growth and Goals for Innovation

Fuel Efficiency Improvements of Transport Aircraft Compared with ACARE Goals

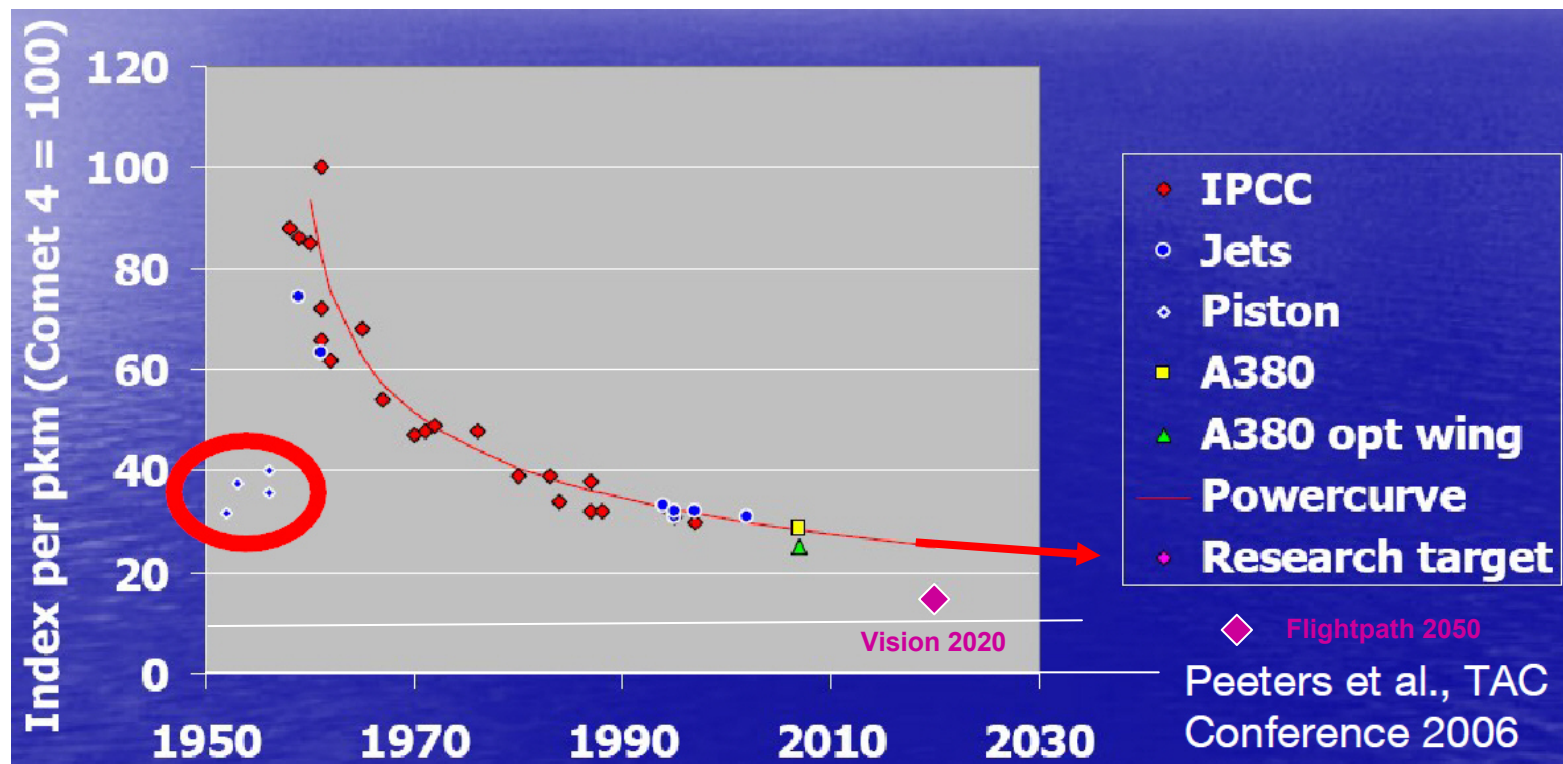

Growth and Goals for Innovation

ACARE Goals Progress Evaluation (AGAPE) Public Summary

Whilst the AGAPE analysis has shown that significant progress has been achieved and is underway for all of the Goals, it also outlined that more efforts are required for the Goals to be fully reached at a uniform pace.

Furthermore, the transition from technology availability to technology uptake in product or system is influenced by many factors and amongst factors of a non-technological nature such as market expectations, new products or improvements being developed. Other factors

...

Romain Muller: *ACARE Goals Progress Evaluation*. AeroSpace and Defence Industries Association of Europe, 2010

Not all ACARE goals from Vision 2020 will be met. This has no consequence, because the goal post has shifted to 2050 with the new Flight Path 2050. Therefore the Vision 2020 is no longer needed.

Growth and Goals for Innovation

Making up for what is Missing: **Introducing Compensation Schemes**

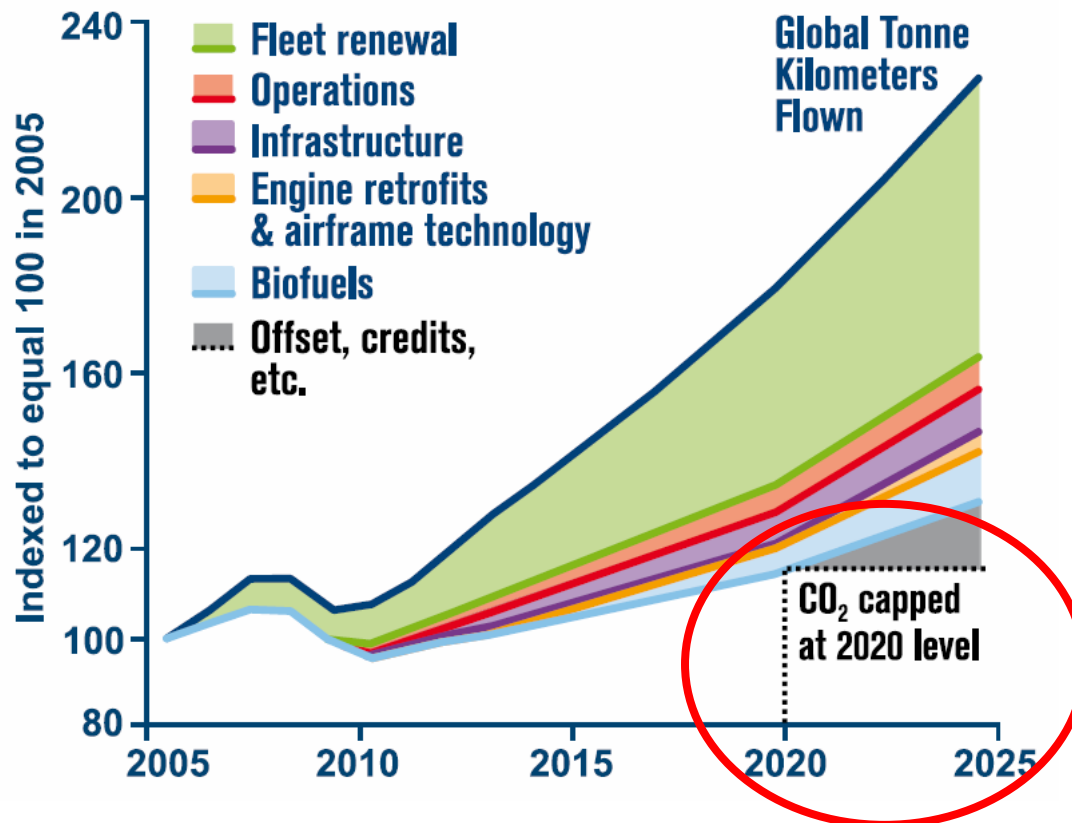

There is no real reason to start with compensation in 2020. **Compensation could as well start today.** If the level of CO₂ concentration in the atmosphere is not considered high enough jet, it may not warrant to start with compensation now.

www.iata.org (12-09-10)

IATA (and ATAG) want to achieve zero emission growth from 2020 onwards. This is only possible with carbon **offset schemes**.

Learning from History Looking into the Future

Learning from History



1. Bust of the American whale oil industry. 1859, Edwin Drake struck oil at Titusville, Pennsylvania. In a few days, Drake extracted as many barrels of oil as a whaling ship could gather on a four-year voyage.
2. British excessive coal usage after the invention of the efficient steam engine by James Watt. [William Jevson](#) analyses the mechanism.

Learning from History Looking into the Future

Jevons Paradox: Why Fuel Can Not Be Saved from Efficiency Increase

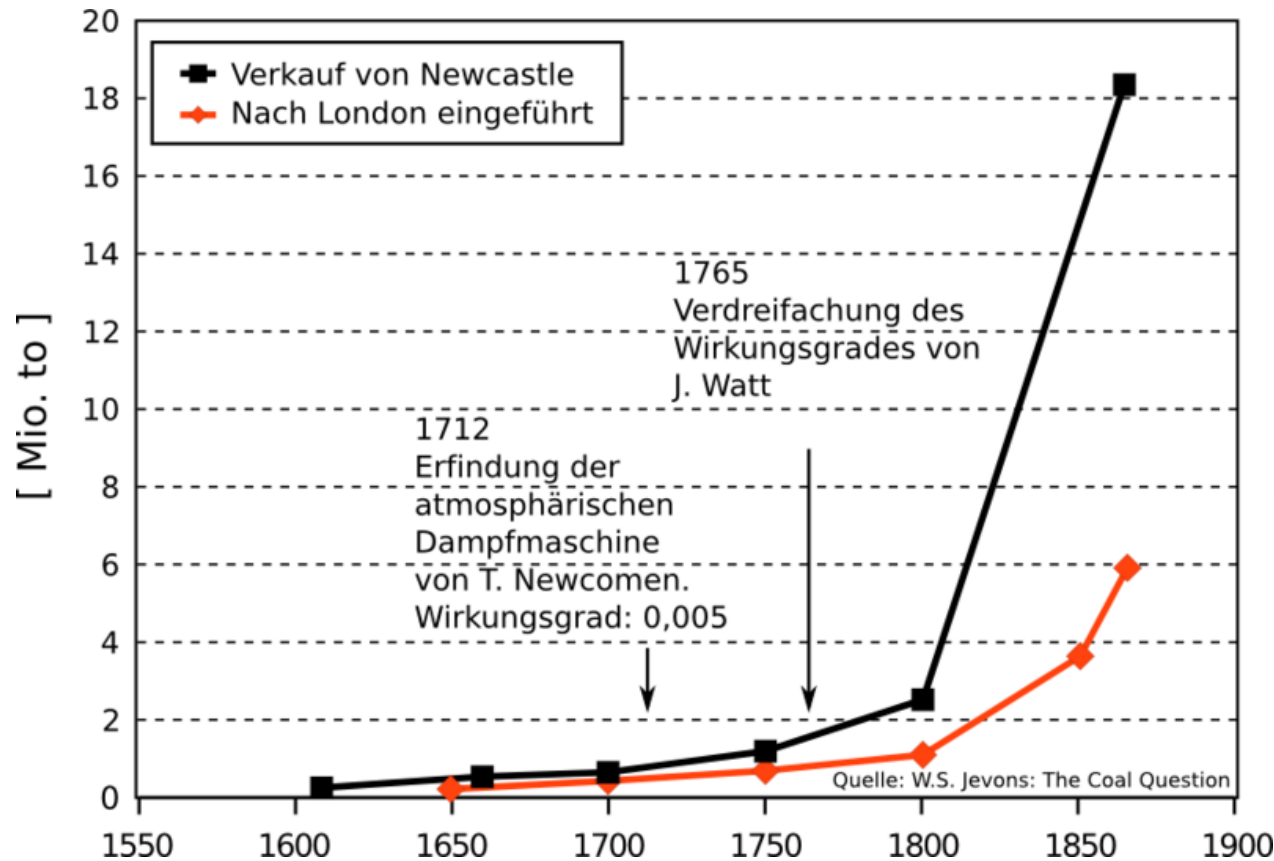

William Jevons
around 1885

de.wikipedia.org
(12-09-10)

Learning from History Looking into the Future

Jevons Paradox: Why Fuel Can Not Be Saved from Efficiency Increase

Technological progress that increases the efficiency with which a resource is used tends to increase (rather than decrease) the rate of consumption of that resource.

Increased energy efficiency tends to increase energy consumption by two means:

1. Increased energy efficiency makes the use of energy relatively cheaper, thus encouraging increased use (the direct rebound effect).
2. Increased energy efficiency leads to increased economic growth, which pulls up energy use for the whole economy (indirect rebound effect).

To ensure that efficiency enhancing technological improvements reduce fuel use, efficiency gains must be paired with **government intervention** that reduces demand (e.g., **green taxes, a cap and trade program**, or higher fuel taxes).



William Jevons
around 1885

Learning from History Looking into the Future

We will have not One but Three Issues!

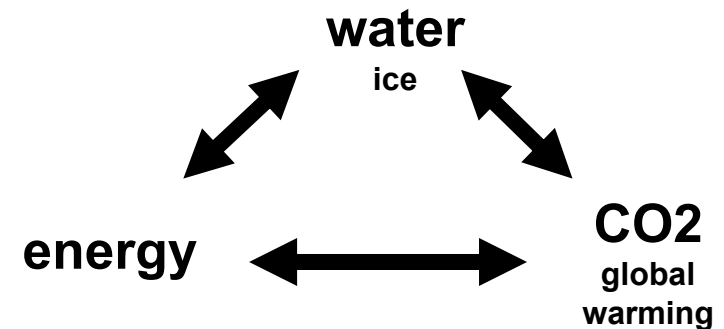

E => CO2 :	Burning Energy produces CO2
CO2 => E :	Splitting CO2 with sunlight gives kerosine (some day): STL
E => W:	Sea water is converted to drinking water with help of energy
W => E:	Water ist needed for BTL (exception: algae)
CO2 => W:	global worming means melting of glaciers <u>the</u> drinking water storage
W => CO2:	melting of glaciers and polar caps means more global worming

So what is of importance?

- 1.) **water**
- 2.) **energy**
- 3.) **CO2**

What is needed?

- 1.) drinking water protection (from pollution)
- 2.) reservoirs (saving water from melting glaciers)
- 3.) wells
- 4.) energy efficient salt water treatment plants

Some Ideas

“Air Travel Evaluator”

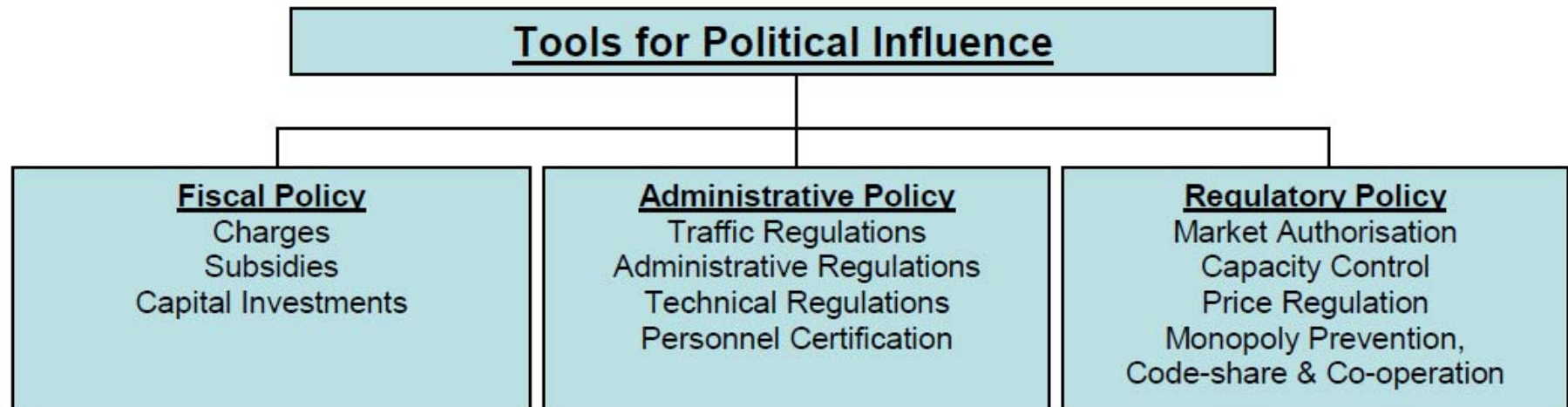

Eco-Efficiency in Aviation – Flying Off Course?

My very personal Summary and Outlook

- **The aircraft is mature**, whatever will come, will not change the game
- With ever more people on this planet, life will get more difficult
- Primary concern in the future is **water**, if water runs out, a war can start in days
- Fossil fuels will come to an end – probably later than we now believe
- Something totally different will be coming after this energy era – we need to work on it
- The change will not be smooth so we need **resilience**
- We spend our resources on too many things that do not matter in the big picture
- We could be advancing at a faster pace if we **get focused on what really matters**

Aircraft Cabin Air Contamination - Health & Flight Safety Implications

A large commercial airplane is shown from a front-on perspective, flying through a clear blue sky with scattered white clouds. The aircraft's nose, cockpit windows, and wings are clearly visible. The engines are mounted under the wings. The overall scene is bright and clear, suggesting a high-altitude flight.

Dr Susan Michaelis, ATPL, PhD
Michaelis Aviation Consulting

Lecture for the German Aerospace Society (DGLR), German Engineering Society (VDI),
Royal Aeronautical Society Hamburg Branch (RAeS) and
Hamburg University of Applied Sciences (HAW Hamburg)

HAW Hamburg, 08.11.2012

<https://doi.org/10.5281/zenodo.7296358>



Deutsche Gesellschaft
für Luft- und Raumfahrt
Lilienthal-Oberth e.V.



ROYAL
AERONAUTICAL
SOCIETY
HAMBURG BRANCH e.V.



VDI

Verein Deutscher Ingenieure
Hamburger Bezirksverein e.V.
Arbeitskreis Luft- und Raumfahrt

Die DGLR lädt ein zum Vortrag in Kooperation mit VDI und RAeS

Aircraft Cabin Air Contamination - Health & Flight Safety Implications



Dr. Susan Michaelis, PhD, ATPL

Vortrag
mit anschließender Diskussion

Eintritt frei!
Keine Voranmeldung!

Zeit: **Donnerstag, 08.11.2012, 18:00 Uhr**
Ort: **HAW Hamburg**
Berliner Tor 5, (Neubau), Hörsaal 01.12



Dr. Susan Michaelis, a former Australian commercial pilot is an aviation health and safety consultant and Head of Research for the Global Cabin Air Quality Executive (GCAQE), the leading labor and consumer organization specifically addressing the issue of aircraft contaminated air. She has widely briefed industry, governments, military and unions, with her 2010 PhD dissertation on this subject being the only one of its kind globally covering a wide spectrum of issues on the contaminated air subject. She holds NEBOSH and COSHH qualifications in health and safety and the use of hazardous substances. She is completing an MSc in Air Safety and Accident Investigation at Cranfield University.

Aircraft air supplies delivered via compressed bleed air combined with the use of highly heated synthetic turbine engine oils has been a subject of concern since the early 1950's and remains an ongoing issue to the present day. Dr. Susan Michaelis will present the findings of her PhD thesis [1] on this subject examining the health and flight safety implications from exposure to unfiltered contaminated air in aircraft. Areas of specific interest include: the short and long-term adverse effects documented supporting a discrete occupational health syndrome, the frequency of exposure, an examination of air monitoring studies undertaken and the suitability of these to suggest the air is healthful or safe and a review of industry knowledge and actions spanning almost 6 decades. Synthetic jet engine oils heated to high temperatures have been long known to become toxic. This happens as a design and operational feature of using bleed air. It has become an accepted and expected occurrence within the aviation industry. The evidence presented warrants that precautionary measures be introduced to address this real health and flight safety issue.

[1] MICHAELIS, Susan: *Health and Flight Safety Implications from Exposure to Contaminated Air in Aircraft*, The University of New South Wales, School of Risk and Safety Sciences, PhD Thesis, 2010. - ISBN: 978-0-9555437-7-7

DGLR / HAW Prof. Dr.-Ing. Dieter Scholz
RAeS Richard Sanderson
VDI Hannes Erben
DGLR Eric Heslop

Tel.: (040) 42875 8825
Tel.: (04167) 92012
Tel.: (040) 743 83481
Tel.: (040) 743 62505

info@ProfScholz.de
events@raes-hamburg.de
hannes.erben@airbus.com
hamburg@dglr.de

DGLR Bezirksgruppe Hamburg
RAeS Hamburg Branch
VDI, Arbeitskreis L&R Hamburg

<http://hamburg.dglr.de>
<http://www.raes-hamburg.de>
<http://www.vdi.de/2082.0.html>

und  Luftfahrtstandort
Hamburg
<http://www.luftfahrtstandort-hamburg.de>

Der Besuch der Veranstaltung ist steuerlich absetzbar. Bringen Sie dazu bitte eine ausgefüllte Teilnahmebestätigung zur Unterschrift zum Vortrag mit. Mittels E-Mail-Verteilerliste wird über aktuelle Veranstaltungen informiert. Vortragsunterlagen vergangener Veranstaltungen, aktuelles Vortragsprogramm, Eintrag in E-Mail-Verteilerliste, Vordrucke der Teilnahmebestätigung: Alle Services über die Internetseite zur gemeinsamen Vortragsreihe von DGLR/VDI/RAeS/HAW: <http://hamburg.dglr.de>.

Safety/Health – 1999 - Malmö



- Both pilots temporarily totally incapacitated in flight.
- Oil leak identified.
- Oil-based chemicals identified in air supply system; (including TCP) no other explanation for symptoms.
- Captain no longer able to fly – loss of medical cert



An Actual Incident



Will they listen?



Hvor lenge skal dette være selskapenes viktigste strategi i håndtering av giftige oljer?



<http://www.headinthesandsymposium.com/event-news.html>

HOUSTON WE HAVE A PROBLEM



James Lovell, Apollo 13



AIRCRAFT DESIGN AND SYSTEMS GROUP (AERO)

Aircraft Cabin Air and Engine Oil – An Engineering Update

Dieter Scholz

Hamburg University of Applied Sciences

<https://doi.org/10.5281/zenodo.4743773>

International Aircraft Cabin Air Conference 2021

Online, 15 - 18 March 2021

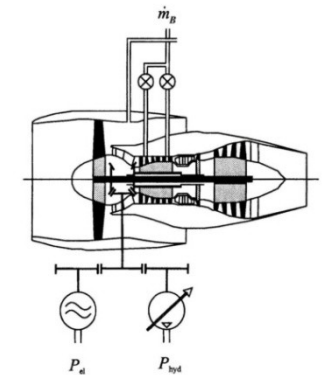
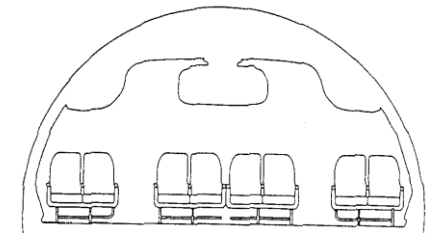

Distribution of Engine Oil with Metal Nanoparticles

Engine Oil in the Potable Water



Potable water contaminated by bleed air on an Airbus A320. The last **water** extracted from the tank before it is empty is **black**, probably **from engine oil residue**.

Picture source:

Video: <https://youtu.be/dIPOeudTTCI>.

The video explained:

<https://purl.org/CabinAir/WaterContamination>.

Distribution of Engine Oil with Metal Nanoparticles

Engine Oil Colors Bleed Air Duct Brown

Fan air and bleed air ducts at the interface between engine and wing on an Airbus A320. The **brown stain** in the bleed air duct appears to be engine **oil residue**. In comparison, the fan air duct is clean. Air temperature in the bleed air duct about **400 °C**.

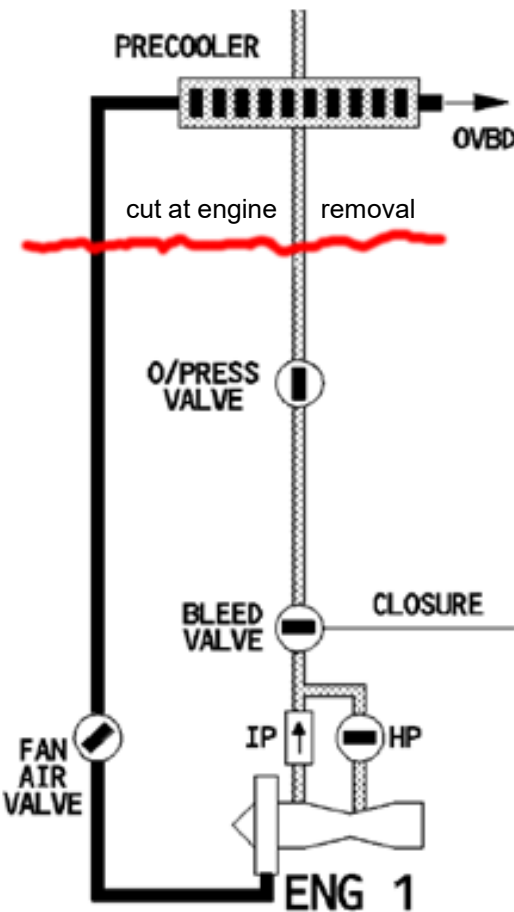

Airbus A320 FCOM

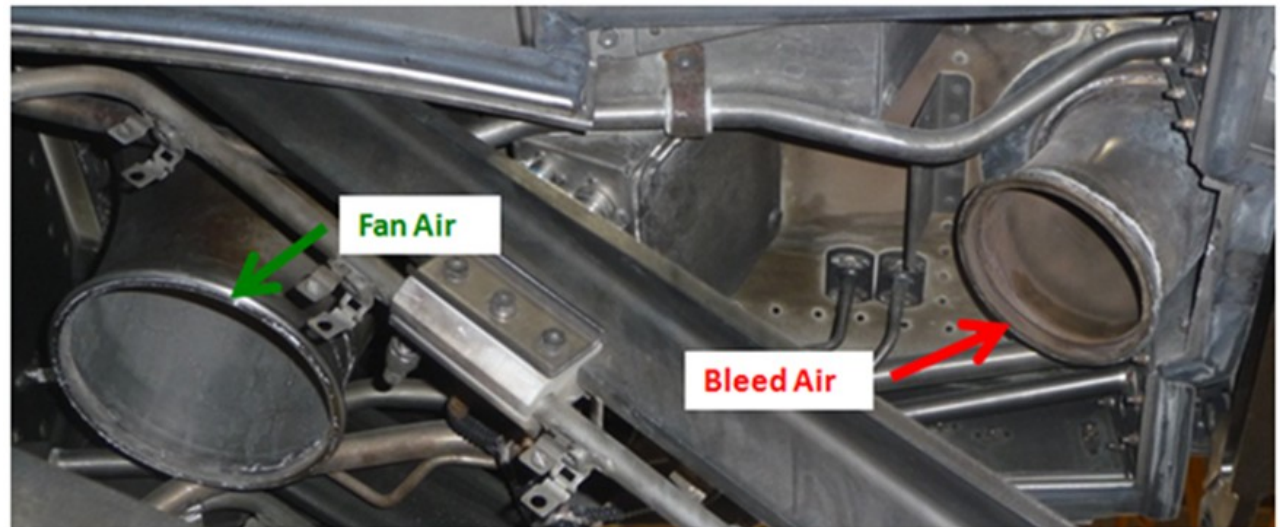

Distribution of Engine Oil with Metal Nanoparticles

Engine Oil Residue Accumulates in Water Extractor

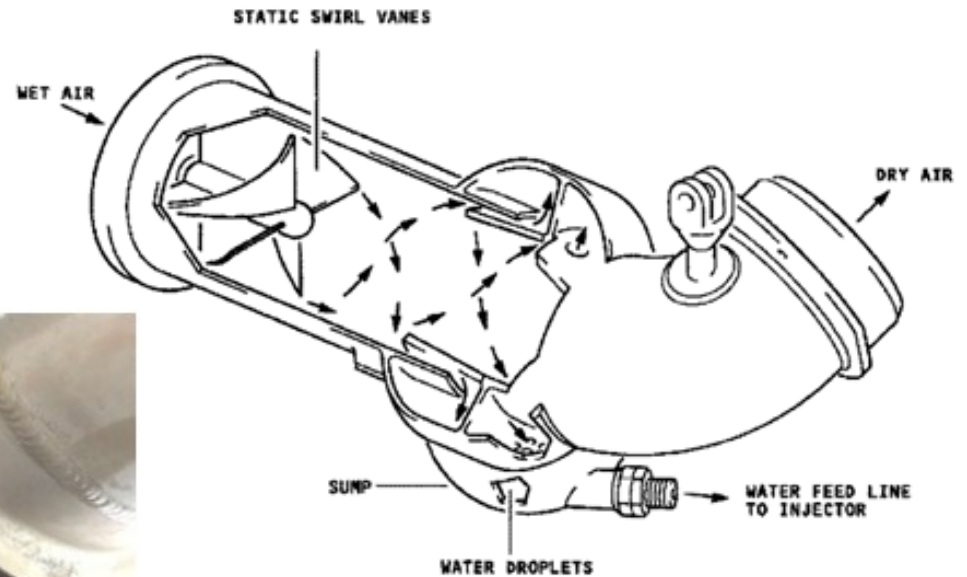
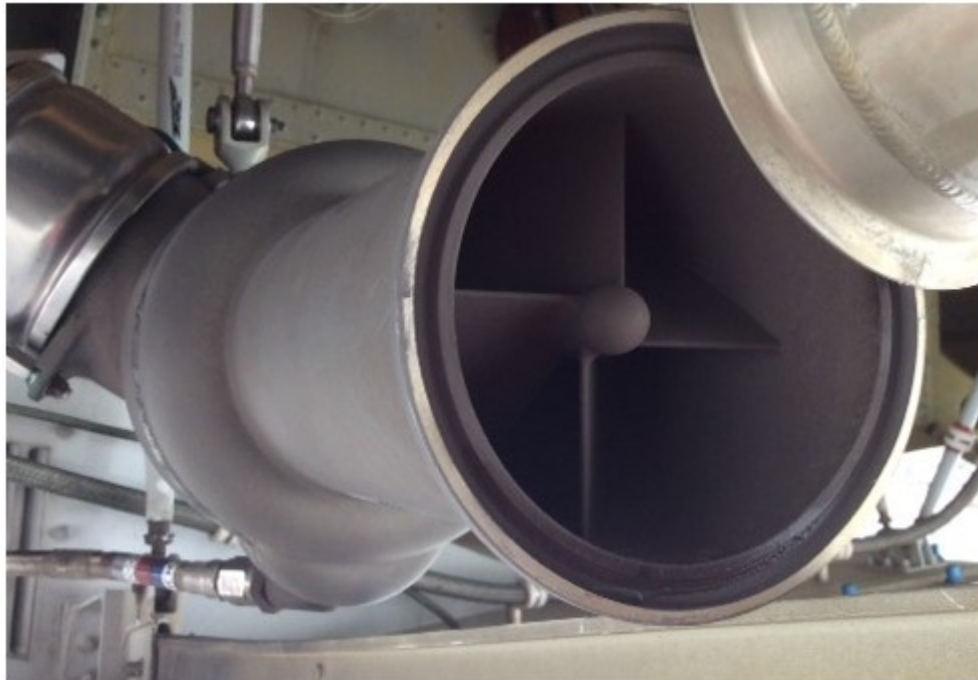

The Airbus A320 **water extractor** (Airbus 1999), is a part of the air conditioning pack. The inlet of the water extractor is covered with **black oily residue**.

Distribution of Engine Oil with Metal Nanoparticles

Engine Oil Colors Cabin Air Duct Black



Airbus A320 air conditioning air distribution duct in the cabin. The inside is black from contaminated bleed air.

Distribution of Engine Oil with Metal Nanoparticles

Engine Oil Colors Cabin Air Duct Black

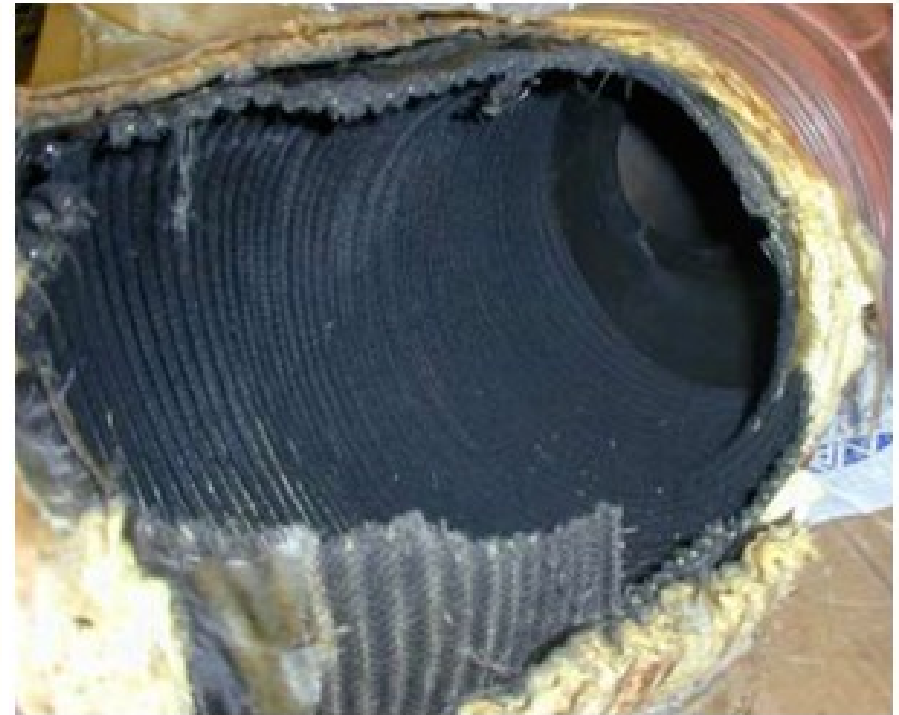
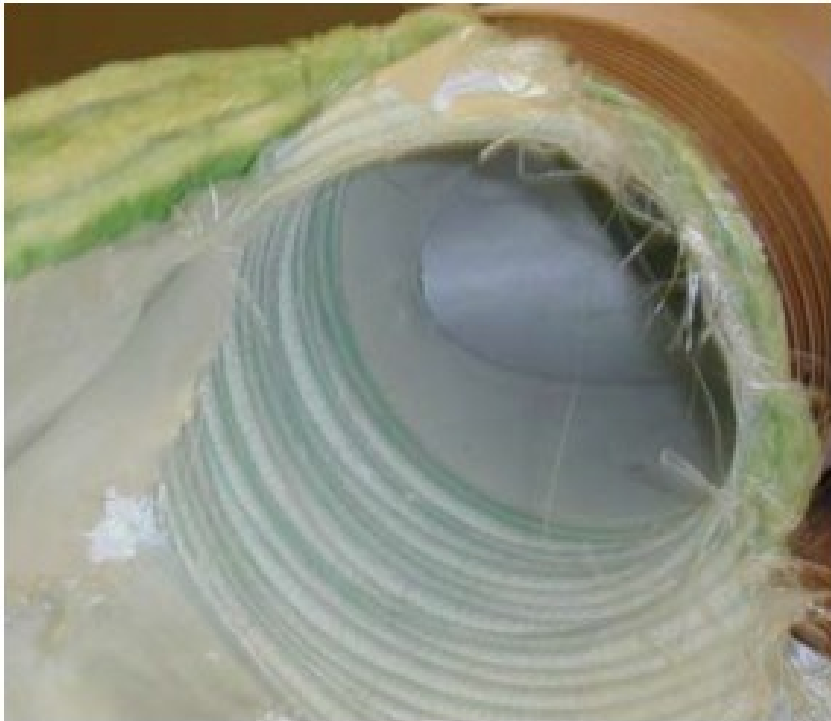

Left: A unused duct supplied new.

Right: A ducts that had been installed downstream of the environmental control system air conditioning packs on a BAe 146 passenger aircraft after 26061 flight hours (CAA 2004).

Distribution of Engine Oil with Metal Nanoparticles

Flow Limiter in Air Conditioning Ducts Clogged



Flow limiter clogged from pyrolysed engine oil in ducts of the air conditioning system of Boeing 757 aircraft with Rolls-Royce RB211-535E4 engines operated by Icelandair (Hansen 2019) compared to a clean flow limiter (top).



Distribution of Engine Oil with Metal Nanoparticles

Engine Oil Colors Riser Ducts Black



Video:

<https://bit.ly/2YXcL3a>



Riser ducts and lower cabin air outlet on an Airbus A320 aircraft. The red line close to the cabin floor shows, where the duct was separated and opened. It is black inside from engine oil residue.

AIRCRAFT DESIGN AND SYSTEMS GROUP (AERO)

Limits to Principles of Electric Flight

Dieter Scholz

Hamburg University of Applied Sciences

<https://doi.org/10.5281/zenodo.4072283>

Deutscher Luft- und Raumfahrtkongress 2019

German Aerospace Congress 2019

Darmstadt, Germany, 30.09. - 02.10.2019

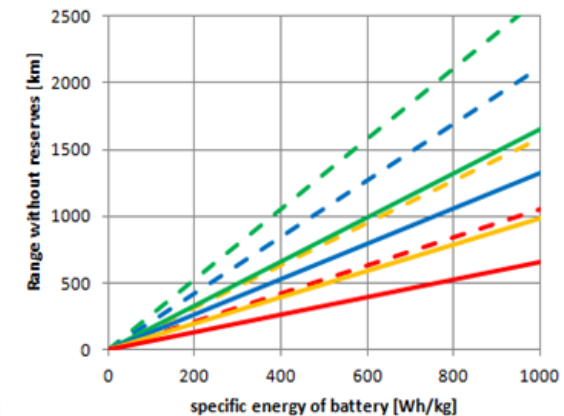
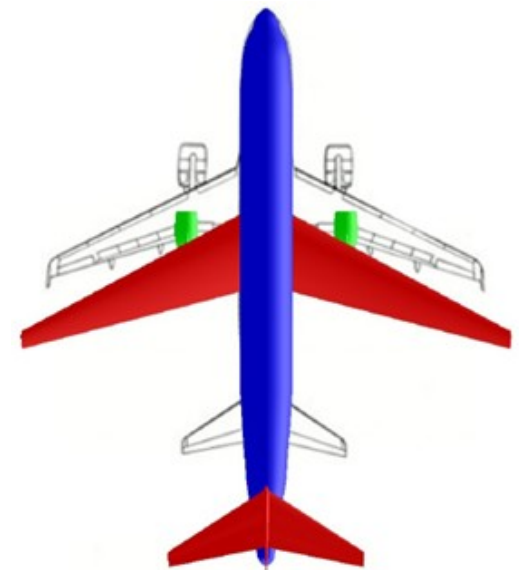

Initial Thoughts

Modes of Transportation and Income

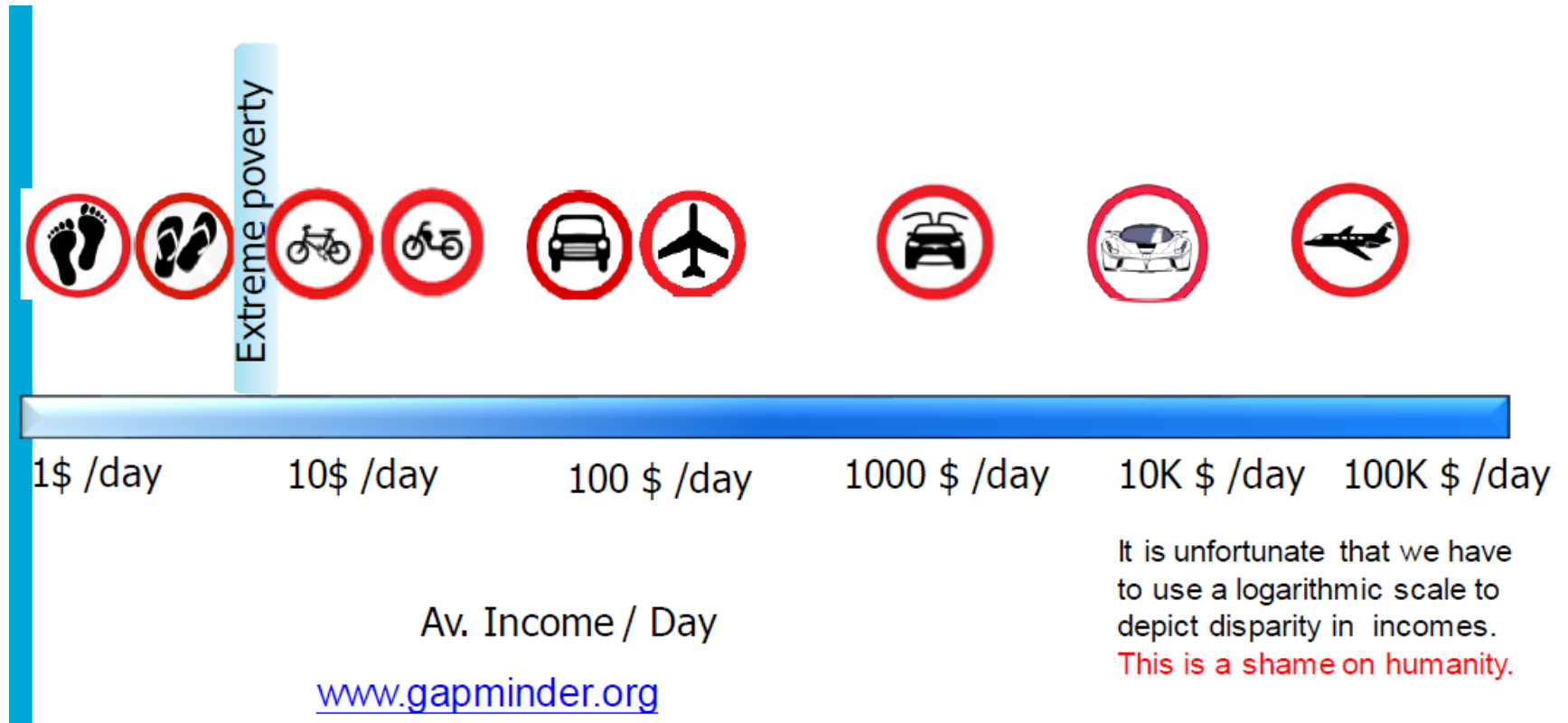

Gangoli Rao 2018

Initial Thoughts

Modes of Transportation and Income



City Airbus, 4 passengers, endurance: 15 min. (Airbus 2017a)



Max Pixel, CC0

Waiting for the City Airbus?



Speed
Comfort
Convenience
Style
Cost
CO2

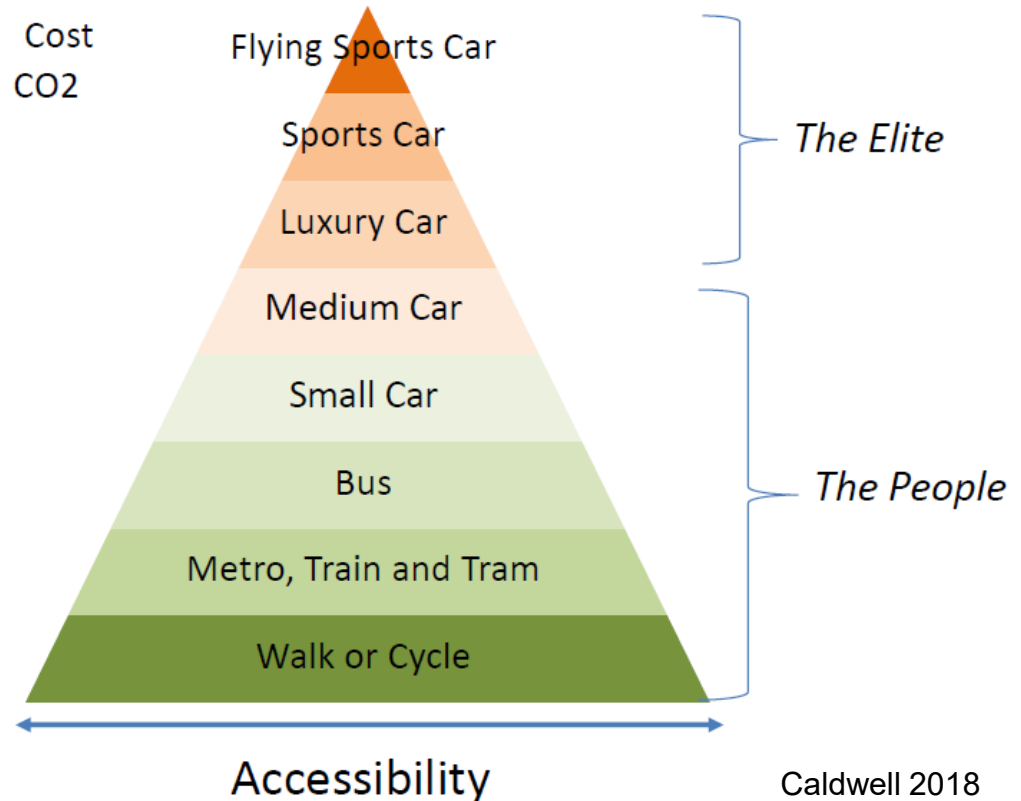

Initial Thoughts

based on Caldwell 2018

Modes of Transportation and CO2

“Flying Taxi”?

.....or “Flying Sports Car”?



Ehang184

Carbon fibre monocoque

360kg

106kW

= **0.29 kW/kg**

CO2=1000g/km (in Dubai)



Lamborghini LP700

Carbon fibre monocoque

1575kg

515kW peak

= **0.33 kW/kg**

CO2=370g/km



VW Golf TDI

4.2 l/100 km

1440 kg

118 kW

= **0.082 kW/kg**

CO2 = 106 g/km



Initial Thoughts

Predicting the Future

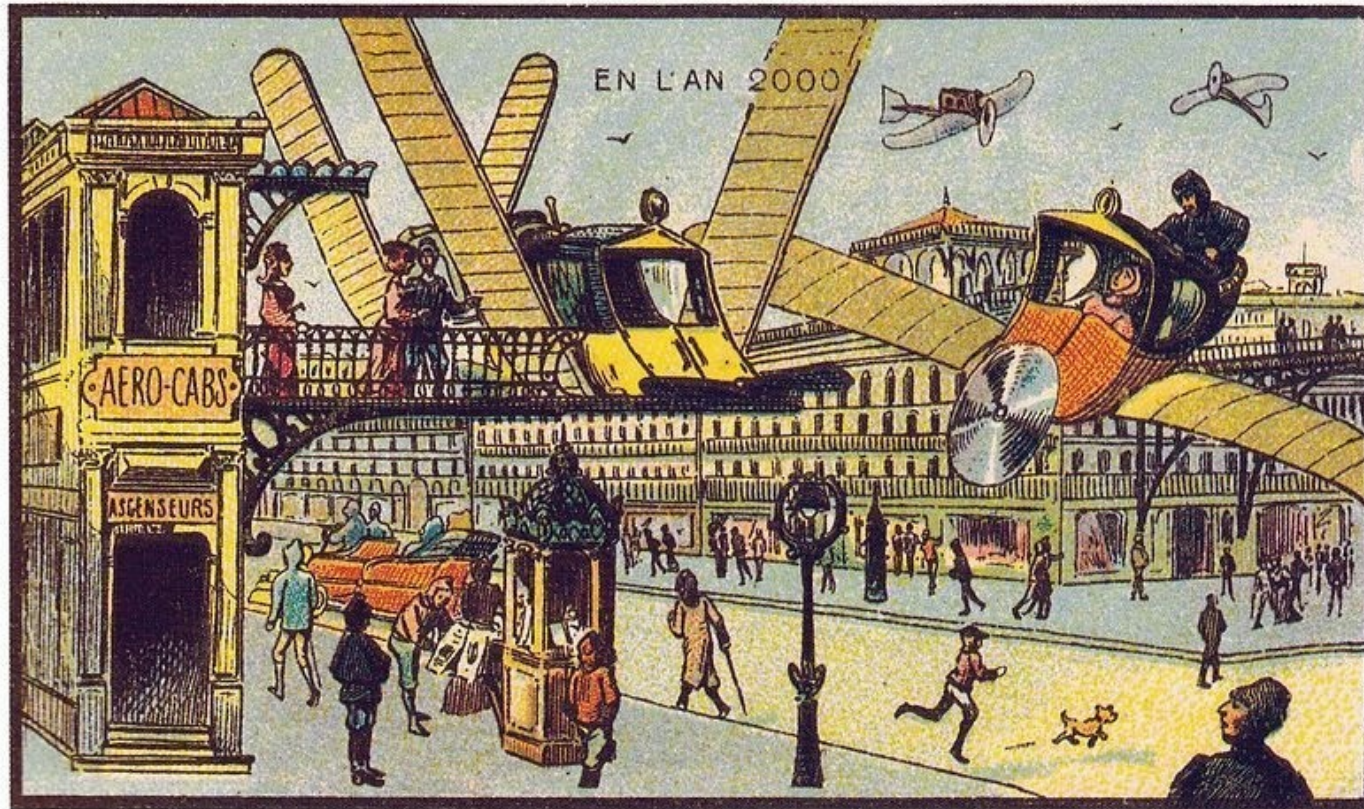

Aero-Cab Station

A french 1899 forecast of "AERO-CABS" in the year 2000

(courtesy of Prof. Zhuravlev)

Selected Projects Evaluated – Media Hype?

Media Hype or Media Circus and Greenwashing

Media Hype

Definition:

A news event for which the level of media coverage is perceived to be excessive or out of proportion to the event being covered.

(https://en.wikipedia.org/wiki/Media_circus)

Greenwashing

Definition:

A form of spin in which green PR or green marketing is deceptively used to promote the perception that an organization's products, aims or policies are environmentally friendly

(<https://en.wikipedia.org/wiki/Greenwashing>)

Criteria (translated):

Missing acts, borrowed plumes, hidden goal conflicts, lack of evidence, vague statements, wrong labels, irrelevant statements, lesser evil, untruths, Deep Greenwash

(<https://de.wikipedia.org/wiki/Greenwashing>)

Selected Projects Evaluated – Media Hype?

E-Fan X Hybrid-Electric Flight Demonstrator

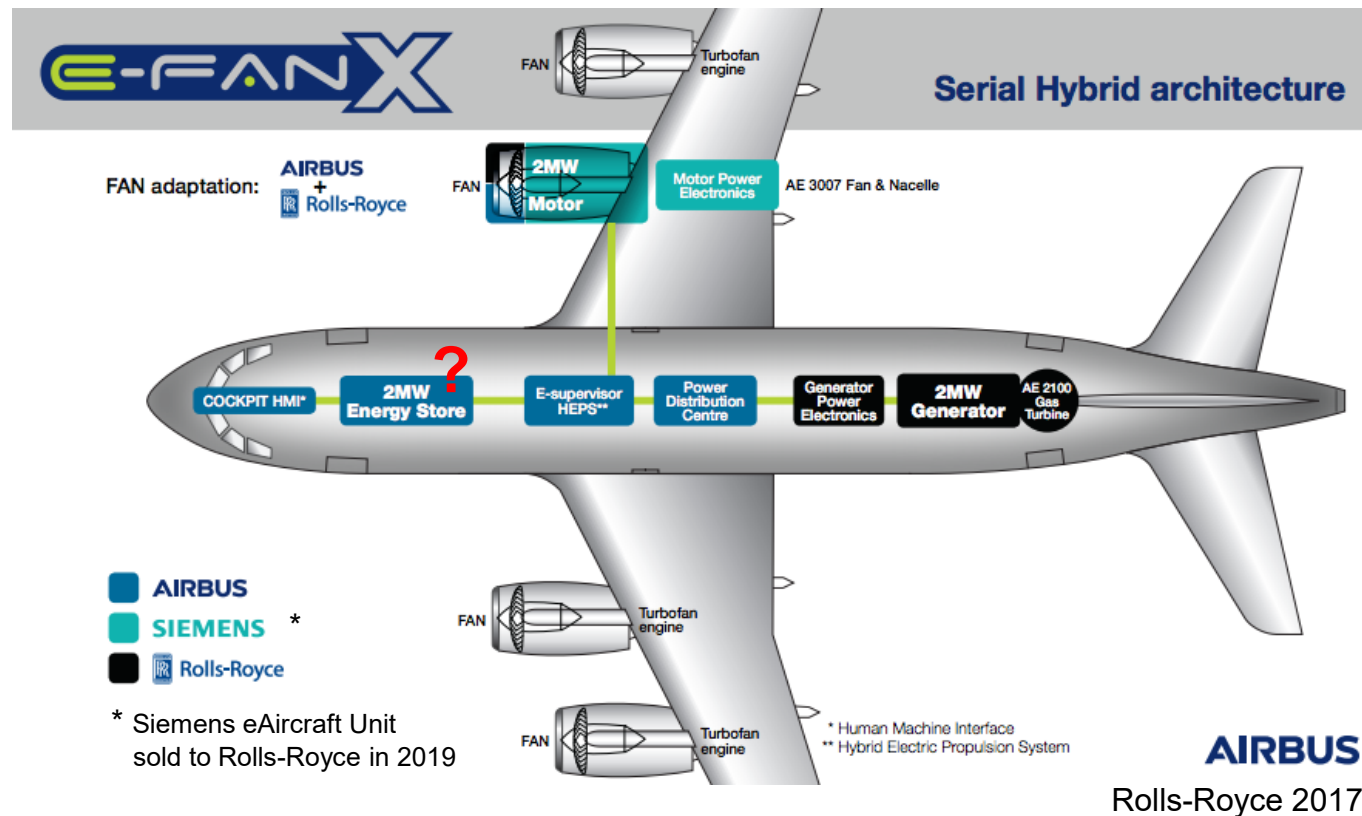

More at RAeS:
Robinson 2017

- Electric engines have at best the same mass as an aviation gas turbine.
- The new propulsion system (gas turbine, generator, electric motor) has **at least 3 times the mass of the original propulsion system**, which could do with only the gas turbine.

Selected Projects Evaluated – Media Hype?

E-Fan X Hybrid-Electric Flight Demonstrator

Evaluation Results:

- Given aircraft => Wing area, maximum loads, mass (MTOW, MZFW) relevant for certification is fixed!
- E-Fan X: Three Lycoming ALF 502 engines (old), one AE2100A turboshaft (new)
- New AE2100A gas turbine is slightly more efficient
- Take-off requires less than 2.5 MW => **no batteries required** (therefore **eliminated here** to improve design)
- Operating empty weight (**OEW**) **increases** => payload (MPL) decreases
=> **number of passengers** n_{pax} **decreases** to 73 (from 82)
- Direct Operating Costs (**DOC**) per passenger seat mile **increase by about 10%**

	OEW (kg)	$m_{F,TOTAL}$ (kg)	MPL (kg)	n_{pax}
<i>Bae 146-100</i>	23820	5667	8612	82
<i>E-FAN X</i>	24722	5608	7667	73
Increase	902	-59	-945	-9
Percentage difference (%)	3.787	-1.042	-10.97	-10.97

Calculations by
Benegas 2019,
HAW Hamburg

Selected Projects Evaluated – Media Hype?

E-Fan X Hybrid-Electric Flight Demonstrator

Greenwashing

Airbus is giving false impression:

"Among the top challenges for today's aviation sector is to move towards a means of transport with improved environmental performance, that is more efficient and less reliant on fossil fuels. The **partners are committed to** meeting the EU technical environmental goals of the European Commission's Flightpath 2050 Vision for Aviation (**reduction of CO2 by 75%**, reduction of NOx by 90% and noise reduction by 65%). These cannot be achieved with the technologies existing today. Therefore, Airbus, Rolls-Royce and Siemens are investing in and focusing research work in different technology areas including electrification. **Electric and hybrid-electric propulsion** are seen today as among the **most promising technologies for addressing these challenges.**"

Airbus 2017b

Translated from German: "The hybrid drive offers advantages above all with regard to noise emissions and consumption. Incidentally, **the e-turbine**, which draws its power from a fossil fueled generator rather than a battery, is **expected to consume** a good **25 percent less.**"

Focus 2017

Selected Projects Evaluated – Media Hype?

easyJet Full Electric Aircraft (9-seat demonstrator: 2019)



Wright 2019

- Design for an **easyJet**-sized aircraft London - Amsterdam, Europe's second busiest route, is seen as a strong contender for **full electric flying** in the future.
- easyJet ... confirmed progress ... towards its strategy to operate ... more sustainably and reduce noise from aviation.
- US start-up company, **Wright Electric**, has commenced work on an electric engine that will power a **nine seater aircraft**.
- Wright Electric partner **Axter Aerospace** already has a **two seater aircraft** flying, and the larger [nine seater] aircraft is expected to start **flying in 2019**.
- Work will commence on an **easyJet-sized aircraft** by aircraft designer Darold Cummings [Aerospace Consultant].
(EasyJet 2018)

More on **Darold B. Cummings** see under: CSULB 2016.

Selected Projects Evaluated – Media Hype?

easyJet Full Electric Aircraft (9-seat demonstrator: 2019)

Greenwashing



Axter 2019

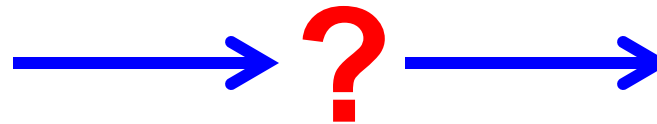

Seats: 2
Year: 2018 (2016)

9
2019

> 100
< 2038? **

Source: Easy Jet 2018

* Axter does not mention the EasyJet project on its website!

* Wright Electric's goal is for every short flight to be zero-emissions within 20 years (Wright 2019).

Selected Projects Evaluated – Media Hype?

Eviation Aircraft: Alice All-Electric Business and Commuter Aircraft

won't
meet
spec

- One main pusher propeller at the tail and two pusher propellers at the wingtips to improve efficiency
 - 9 passengers (plus 2 pilots) up to 650 sm (1000 km) at a cruise speed of 240 kt
 - Li-Ion battery: 900 kWh
 - MTOW: 6350 kg
- (<https://www.eviation.co/alice> as of 2019)

- Battery mass is 65% of total aircraft mass (without payload)
 - Specific energy of battery is 400 Wh/kg [much too high]
- (<https://www.eviation.co/alice> as of 2017)



Sarsfield 2019

- Service entry is expected in 2022
- Maximum payload: 1250 kg (including pilots).
This is only 13.7% of MTOW (low due to batteries).
- 183 kg cargo (with assumed 97 kg per person)
- Direct Operating Costs (DOC): 200 USD per flight hour with 11 person at 240 kt (Hemmerdinger 2019)

Own calculations based on given data:

- OEW: 2043 kg
- battery mass: 3434 kg
- OEW/MTOW = 0.32 (too low)
- Specific energy of battery calc.: 285 Wh/kg (high)
- L/D in cruise: 17.5 (based on 400 Wh/kg)
- L/D in cruise: 24.5 (based on 285 Wh/kg) (too high)

Selected Projects Evaluated – Media Hype?

ZUNUM Aero: Commuter Aircraft – Series Hybrid with Range Extender

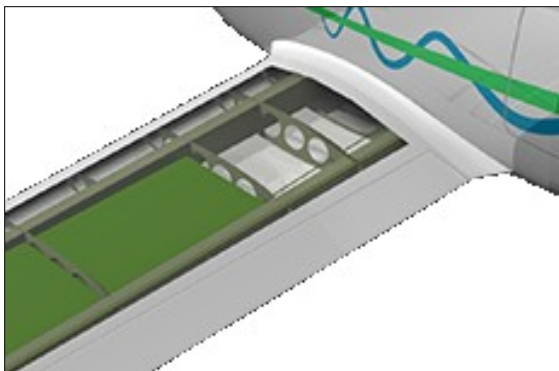
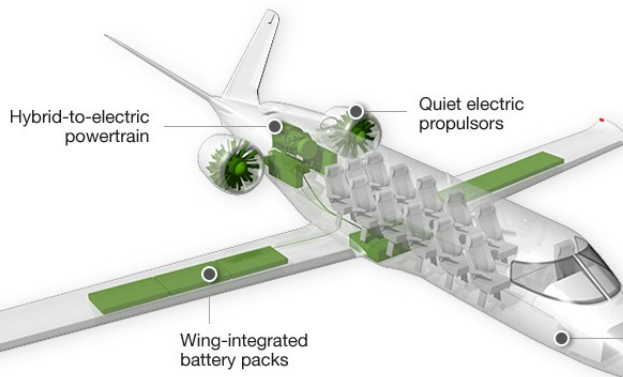

Zunum 2019

Selected Projects Evaluated – Media Hype?

ZUNUM Aero: Commuter Aircraft – Series Hybrid with Range Extender

Zunum's 2022 Aircraft by the Numbers

Weights (lb.)

Max. takeoff	<12,500
Max. payload	2,470
Standard fuel	800
Battery weight	<20% of MTOW

Performance

Max. cruise speed	340 mph
Max. range	>700 mi.
Max. altitude	25,000 ft.
Takeoff distance	2,200 ft.
Landing distance	2,500 ft.
Time to 25,000 ft.	18 min.
Stall speed	73 kt.
Max. power	1-megawatt class
Emissions	<0.3 lb. CO ₂ /ASM
Sideline noise	65 EPNdB

Source: Zunum Aero

Warwick 2017

Greenwashing

Zunum 2019: 11500 lbs = 5216 kg
 Zunum 2019: 2500 lbs = 1134 kg
 = 363 kg (will give range of about 1250 km = 780 SM as specified)
very low for battery electric flight

= 295 kt this gives $M = 0,49$ in 25000 ft
 meant are 700 SM = 608 NM = 1126 km **guaranteed by fuel !!!**

Zunum 2019:
 12 pax => 94.5 kg / pax (**low**)
 battery mass (@ 20% MTOW): 2300 lbs = 1043 kg
 OEW = 5900 lbs = 2676 kg
 OEW/MTOW = 0,51 (realistic)
 With 250 Wh/kg, L/D=18: **battery range = 238 km = 148 SM**

Aircraft flies only 21% of its range on batteries!

Selected Projects Evaluated – Media Hype?

Diamond Aircraft Multi-Engine Hybrid Electric Aircraft (based on DA40)



Diamond 2018

- First flight: 31st of October 2018 at Diamond Aircraft's headquarters in Wiener Neustadt, Austria.
- Two electric engines have been added on a forward canard, which combined can generate 150kW of take-off power.
- The diesel generator is located in the nose of the aircraft and can provide up to 110kW of power.
- Two **batteries** with 12 kWh each are mounted in the rear passenger compartment [**taking two of the four seats!**], and act as an energy storage buffer.
- Pure electric, the aircraft has an endurance of approximately 30 minutes. The hybrid system extends this to 5 hours.
- The objective of future flight tests will be to **determine the exact efficiency increase** achieved in comparison to similar non-electric aircraft.

Remark: Direct Operating Costs (DOC) per passenger seat will roughly **double** with only 2 seats instead of 4!

Validation – Are we Doing the Right Thing?

Grid Connected Electric Mobility Operates Successfully on Tracks!



- Aircraft: *Induced drag* is drag due to Lift = Weight. Train: *Rolling Friction* is also drag due to Weight.
- Aircraft: For minimum drag, *induced drag* is 50% of total drag.
- For the same weight, **rolling friction** of a train is **5% of the induced drag** of an aircraft!
- This means: For the same weight, **drag of an aircraft is reduced by $\approx 47.5\%$ if put on rails!**

Aircraft Design for Electric Propulsion

Savings due to a Large Number of (Electric) Engines? – Climb OEI: $\sin \gamma$

CS 25.121 Climb: one-engine-inoperative

(b) Take-off; landing gear retracted.

In the take-off configuration existing at the point of the flight path at which the landing gear is fully retracted, ... the **steady gradient of climb** may not be less than

$\sin \gamma$ ↓ 2.4% for **two-engined** aeroplanes,
 2.7% for **three-engined** aeroplanes and
 3.0% for **four-engined** aeroplanes,
 at V_2 and with -

$$\frac{T_{TO}}{m_{MTO} \cdot g} = \left(\frac{n_E}{n_E - 1} \right) \cdot \left(\frac{1}{E} + \sin \gamma \right)$$

(1) The critical engine inoperative and the remaining engines at the available maximum continuous power or thrust

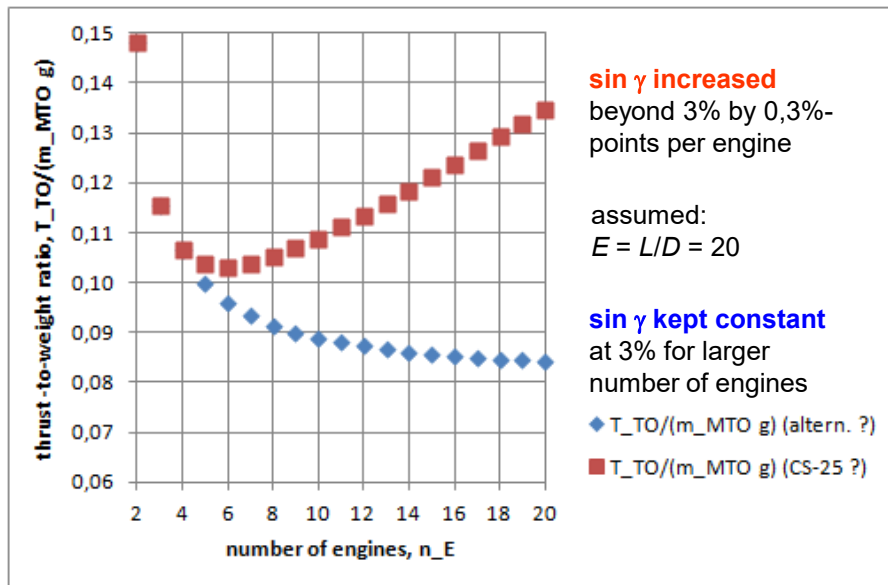

- It depends on the required **climb gradient, $\sin \gamma$** .
- It is **not defined today**, how a One-Engine-Inoperative (OEI) climb is treated by CS-25 with respect to $\sin \gamma$.
- **Many engines** could also lead to **increased thrust requirements!?**

T_{TO} : Take-Off thrust

m_{MTO} : Maximum Take-Off mass

g : earth acceleration

n_E : number of engines

$\sin \gamma$: climb gradient

Aircraft Design for Electric Propulsion

Savings due to a Large Number of (Electric) Engines? – One Engine Inop or More?

CS 25.107 Take-off speeds

(a)(1) V_{EF} is the calibrated airspeed at which **the [one] critical engine** is assumed to fail.

CS 25.109 Accelerate-stop distance

(a)(1)(ii) Allow the aeroplane to accelerate ... assuming **the [one] critical engine** fails at V_{EF}

CS 25.121 Climb: **one-engine-inoperative**

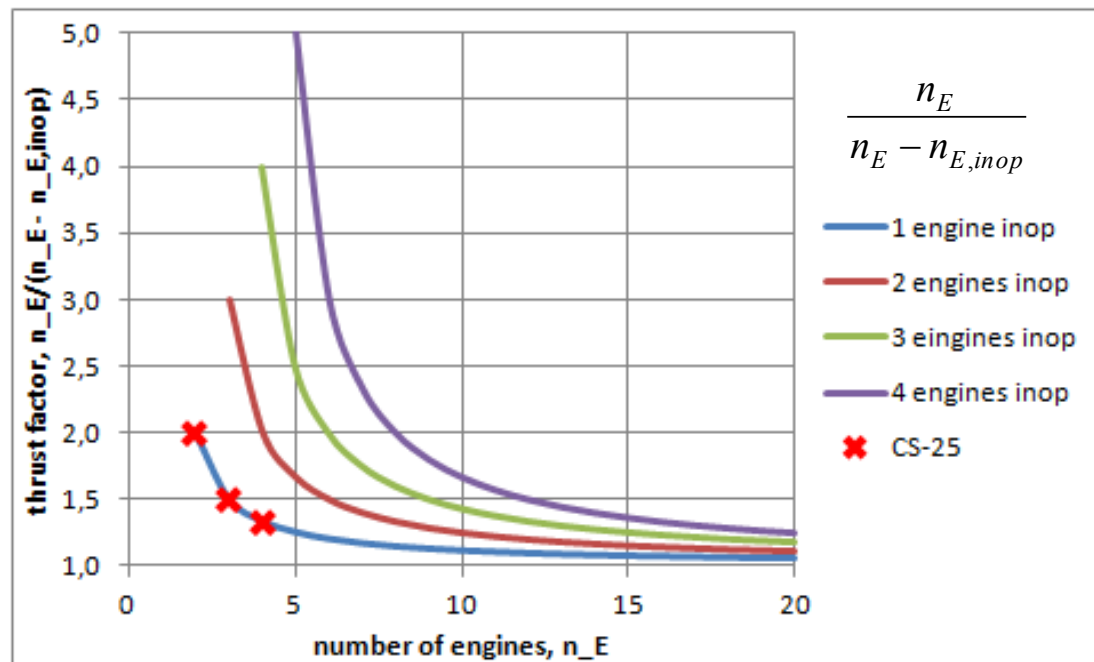

$$\frac{T_{TO}}{m_{MTO} \cdot g} = \left(\frac{n_E}{n_E - 1} \right) \left(\frac{1}{E} + \sin \gamma \right)$$

general thrust factor: $\frac{n_E}{n_E - n_{E,inop}}$

- For a design with very many engines n_E , **EASA / FAA could re-define the thrust factor.**
- The number of engines assumed inoperative $n_{E,inop}$ could be increased:
 $n_{E,inop} > 1$, for larger n_E
- 4 engines with 1 failed need a thrust factor of 1.33. 20 engines with 4 failed need a thrust factor of 1.25 – only slightly less. However, probability for 4 engines failed from 20 is very low.
- Applied, this **could reduce the advantage of many engines.**

Aircraft Design for Electric Propulsion

Investigation of Propeller Area ...

... at least 2 times bigger with only 4 engines instead of 8 engines!

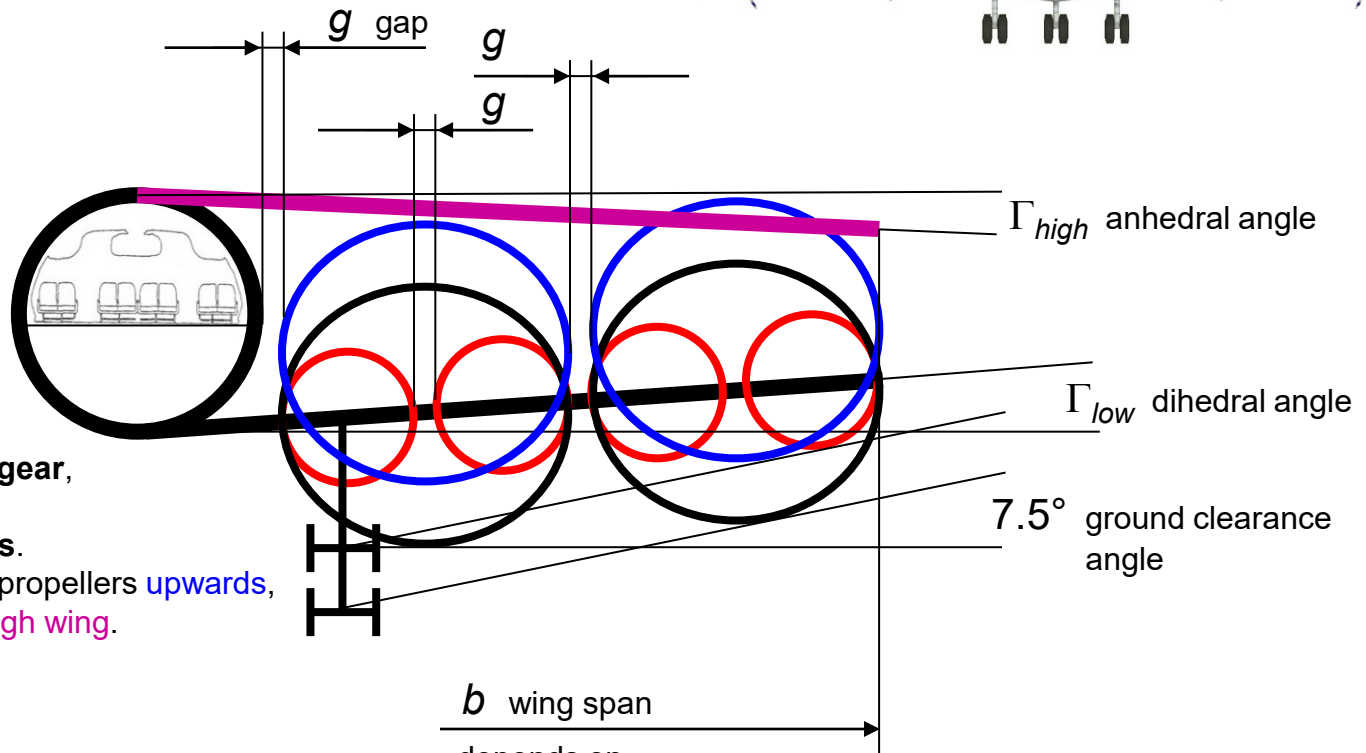
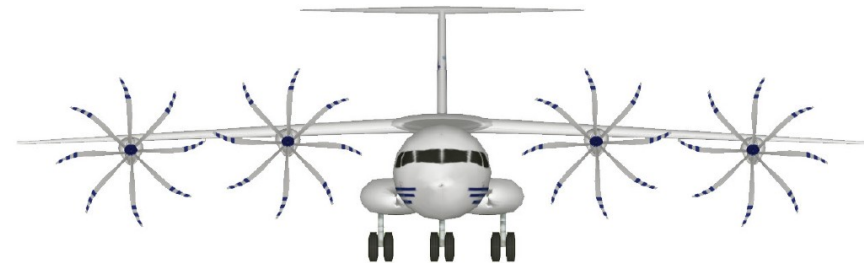

length of landing gear,
depends on
number of engines.

Alternatively: shift propellers upwards,
maybe mount on high wing.

b wing span

depends on

ICAO aerodrome reference codes

24 m, 36 m, 52 m, 65 m, 80 m

=> propellers should not exceed wing tip!

Aircraft Design for Electric Propulsion

... in Contrast Rolls-Royce thinks ...

Translated from German: "For Rolls Royce, for example, a gas turbine uses a generator to produce the electricity used for electric motors and on-board functions. The aim is to **save up to 35 percent** of the **emissions** of an aircraft in this way by changing the **aircraft design with numerous small, electrically driven propellers**", says Ulrich Wenger, head of technology at the engine manufacturer.

Rolls-Royce (NAS 2016)



Rolls-Royce (NAS 2016)

Aircraft Design for Electric Propulsion

Maximum Range for Electrical Propulsion

$$e_{bat} = \frac{E_{bat}}{m_{bat}} \quad L = W = m_{MTO} g \quad E = \frac{L}{D} \quad D = \frac{m_{MTO} g}{E}$$

$$P_D = DV = \frac{m_{MTO} g}{E} V = P_T = P_{bat} \eta_{prop} \eta_{elec} \quad V = \frac{R}{t}$$

$$P_{bat} = \frac{E_{bat}}{t} = m_{bat} e_{bat} \frac{V}{R}$$

$$m_{bat} e_{bat} \frac{V}{R} \eta_{elec} \eta_{prop} = \frac{m_{MTO} g}{E} V$$

$$R = \frac{m_{bat}}{m_{MTO}} \frac{1}{g} e_{bat} \eta_{elec} \eta_{prop} E$$

$$\eta_{elec} = 0.9; \quad \eta_{prop} = 0.8$$

○ : realistic parameters

e_{bat} : specific energy
 E_{bat} : energy in battery
 E : glide ratio (aerodynamic efficiency)
 L : lift
 D : drag
 W : weight
 V : flight speed
 R : range
 t : time
 g : earth acceleration
 P : power
 η : efficiency (prop: propeller)

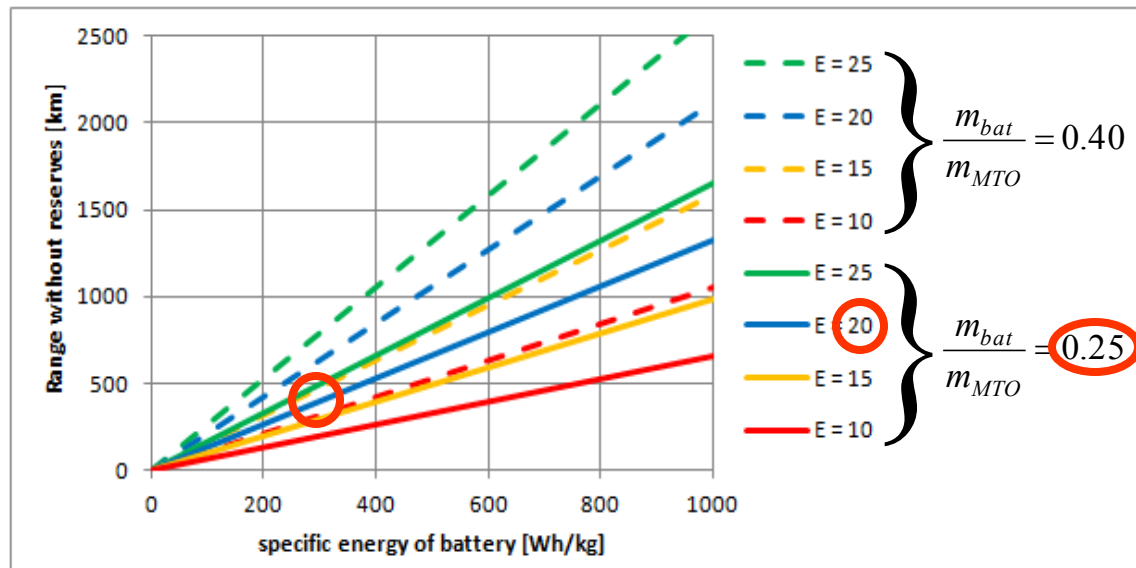

Environmental Evaluation

Battery Powered A320

- Only design solution with Range reduced by 50% => not a fair trade-off <=
- Specific Energy: 1.87 kWh/kg
- Energy density: 938 kWh/m³
- Batteries in LD3-45 container
- 2 container in cargo compartment
- 13 container forward and aft of cabin
- Fuselage stretched by 9 m to house batteries
- MTOW plus 38%
- Battery mass plus 79% (compared with fuel mass)
- On study mission (294 NM) environmental burden (SS) down by 45% (EU electrical power mix)

Parameter	Value	Deviation from A320
Requirements		
m_{MPL}	19256 kg	0%
R_{MPL}	755 NM	-50%
M_{CR}	0.76	0%
$\max(s_{TOFL}, s_{LFL})$	1770 m	0%
n_{PAX} (1-cl HD)	180	0%
m_{PAX}	93 kg	0%
SP	29 in	0%
Main aircraft parameters		
m_{MTO}	95600 kg	30%
m_{OE}	54300 kg	32%
m_F	22100 kg	70%
S_W	159 m ²	30%
$b_{W,geo}$	36.0 m	6%
$A_{W,eff}$	9.50	0%
E_{max}	18.20	$\approx +3\%$
T_{TO}	200 kN	38%
BPR	6.0	0%
h_{ICA}	41000 ft	4%
S_{TOFL}	1770 m	0%
S_{LFL}	1450 m	0%
Mission requirements		
R_{Mi}	294 NM	-50%
$m_{PL,Mi}$	13057 kg	0%
Results		
$m_{F,trip}$	7800 kg	72%
SS	0.0095	-45%

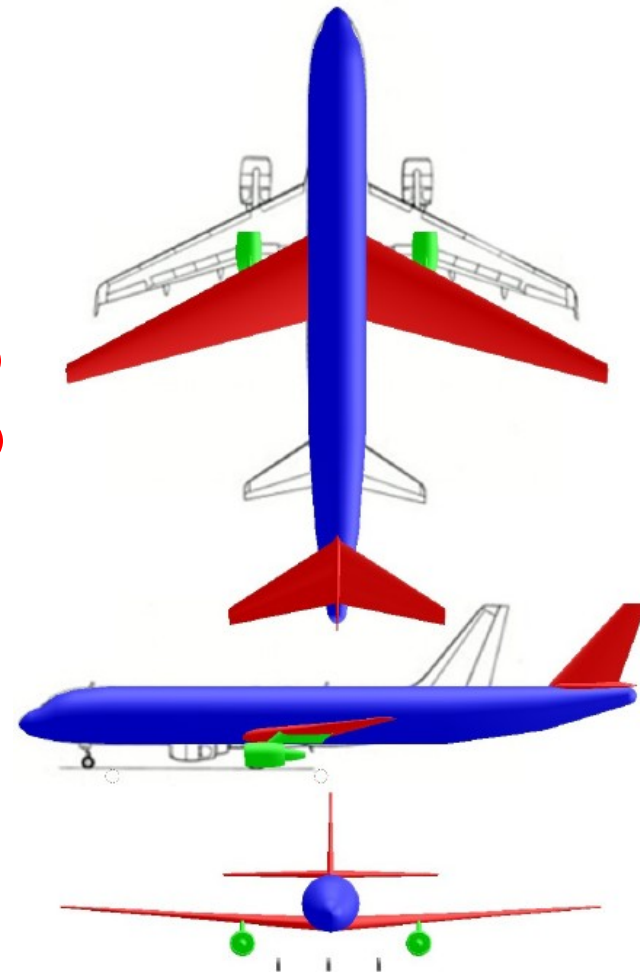

AIRCRAFT DESIGN AND SYSTEMS GROUP (AERO)

Aircraft Cabin Ventilation in the Corona Pandemic – Legend and Truth

Dieter Scholz Hamburg University of Applied Sciences

Hamburg Aerospace Lecture Series (Aero Lectures)

DGLR, RAeS, VDI, ZAL, HAW Hamburg

Online, 24 June 2020

<https://doi.org/10.5281/zenodo.5356568>



Legend or **Truth**

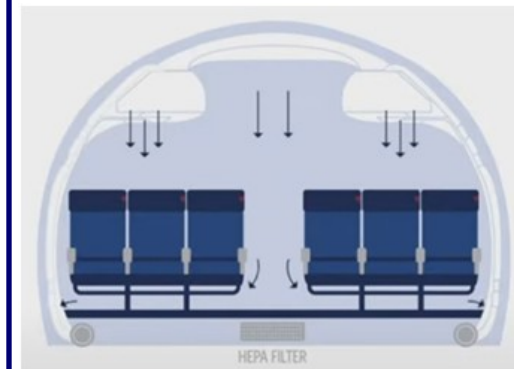

Delta

Aircraft Cabin Ventilation in the Corona Pandemic – Legend and Truth

Independent Project at HAW Hamburg: "Flying During the Corona Pandemic"



- Press Releases, **Memos**: 8 documents.
- **Media production** with my contribution:
 - Radio / TV: 14
 - Print: 18
 - Online: 26
 - Own Video: 1

<http://corona.ProfScholz.de>

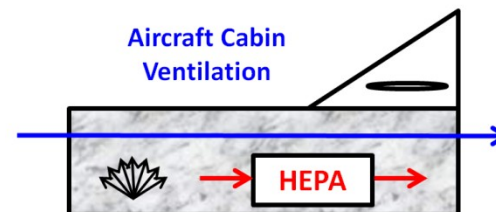

Air Conditioning System (ATA 21)

Overview

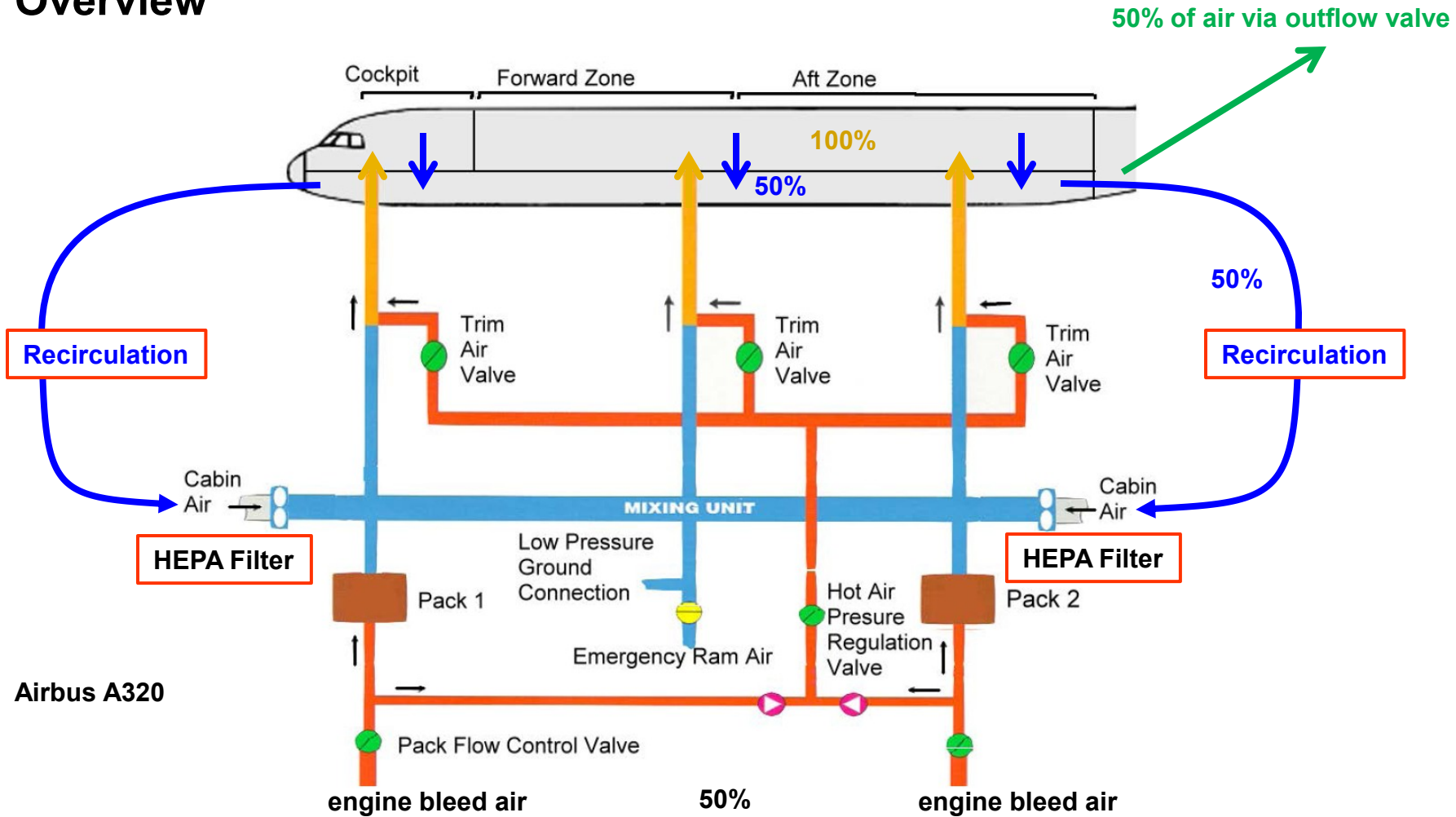

Airbus A320

Air Conditioning System (ATA 21)

Overview – Simplified Version

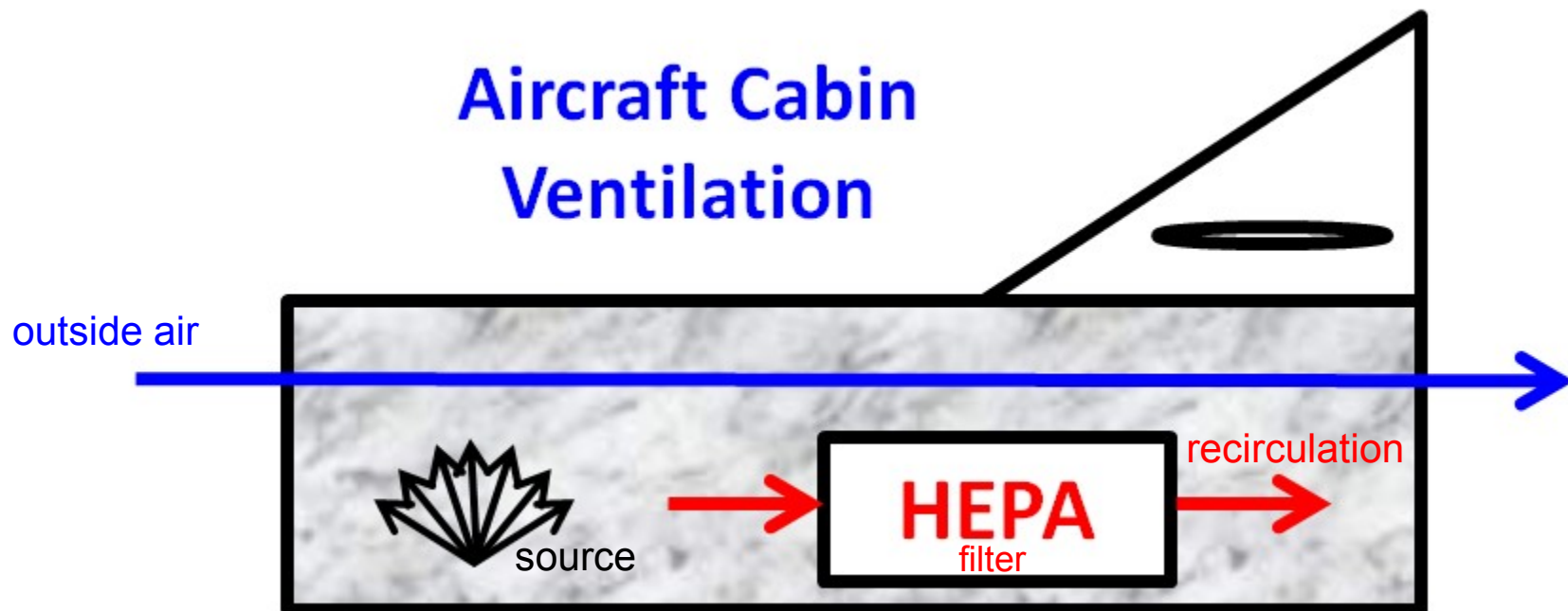

Aircraft Cabin Ventilation in the Corona Pandemic – Legend and Truth

Cabin Ventilation Theory

Cabin Ventilation Theory

Ventilation Equation

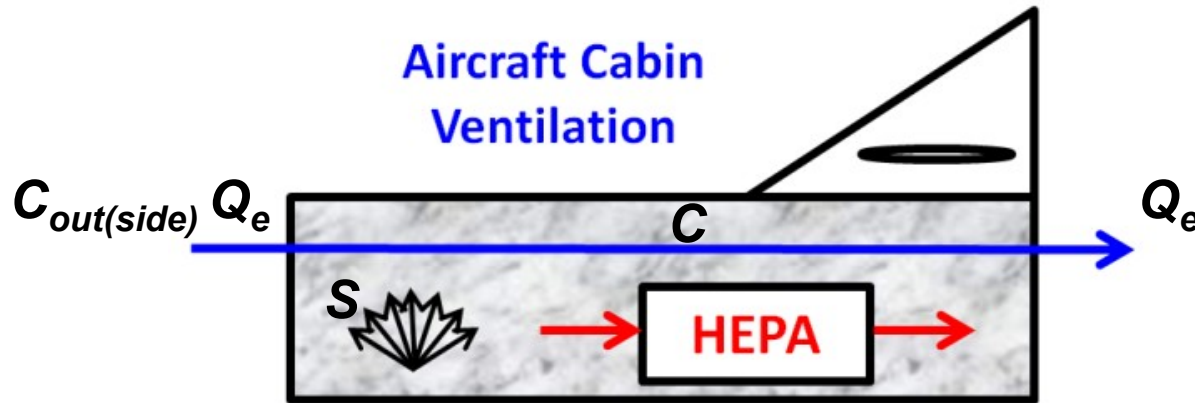

$$S + Q_e C_{out} - Q_e C = V \frac{dC}{dt}$$

- S: source strength in kg/s
- Q_e: effective air flow rate for ventilation in m³/s
- C: concentration of CO₂ or any other substance in kg/m³ in the room
- C_{out}: concentration of CO₂ or any other substance in kg/m³ outside of the room
- V: volume of the room

Dieter Scholz:

Aircraft Cabin Ventilation Theory,
Memo, 2020-06-27.

<https://doi.org/10.31224/osf.io/ac6p8>

See this document for a List of References mentioned in this section.

Cabin Ventilation Theory

Solving the Ventilation Equation for Steady State

If C_{out} is zero, the respective term can be deleted from the equation. The same is true, if **C** is understood as the difference of the concentration to the outside (ambient) concentration.

$$S - Q_e C = V \frac{dC}{dt}$$

In case of a **steady state** situation (no change in concentration C), the equation simplifies to

$$C = \frac{S}{Q_e}$$

We learn: The **concentration** is independent of the volume V and **depends only on the source strength S and the effective air flow rate Q_e .**

Cabin Ventilation Theory

Air Change Rate and Time for One Air Change

The **air change rate** n (in 1/h) is

$$n = \frac{Q}{V}$$

Q : **air flow rate** for ventilation in m^3/s

The **time for one theoretical air exchange**, t_{n1} is

$$t_{n1} = 1/n \quad .$$

Cabin Ventilation Theory

Visualizing the Unsteady Ventilation Equation

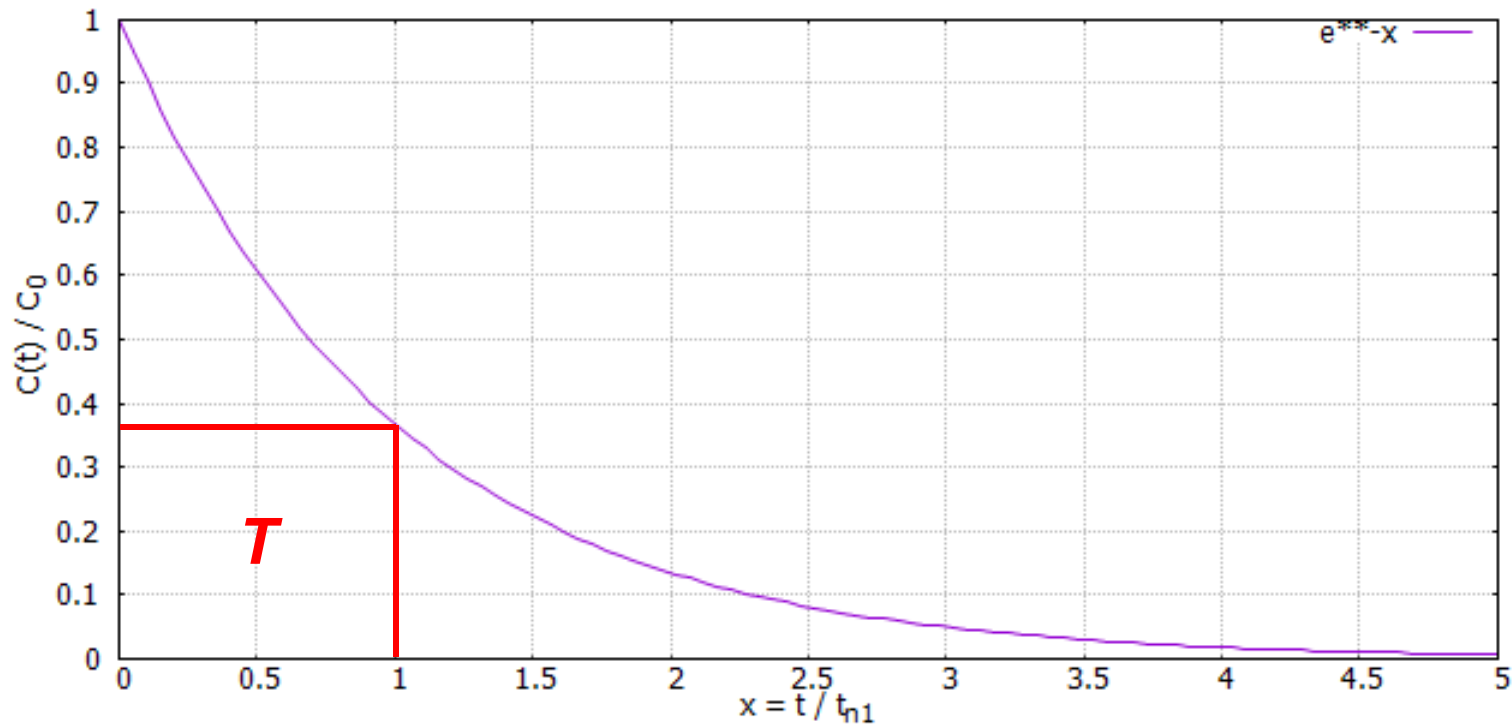

Relative remaining concentration for a ventilation efficiency of $\eta = 1$ versus relative time.

Hence, rinsing is an asymptotic process. A relative concentration will only reach the value 0% of the initial amount after an infinitely long time.

Cabin Ventilation Theory

Time to "Fully Renew" (1%, ISO 14644-3) the Air in a Room

If $\eta = 46.05\%$ is assumed (Wikipedia 2020)

$$t = 10.0 t_{n1}$$

We learn: **The air in a room will never be "fully renewed", but a remaining concentration of 1% may be accepted to call this "fully renewed"** (in accordance with ISO 14644-3). As a rule of thumb "fully renewed" is achieved during a time about ten times the time for one (theoretical) air change.

If the time for one (theoretical) air change is 3 minutes, the air can be considered to be "fully renewed" in 30 minutes.

Legend or Truth?

Legend or Truth?

Industry Claim 1:

The air in the aircraft **"as clean as in a hospital operating theatre"**
(due to HEPA filters)

- **Wrong logic applied:** Even if the HEPA filters would filter out 100% of the viruses in the SUPPLIED air, the AIR IN THE CABIN is still NOT virus free, because the viruses are in the cabin in the first place.
- **50% reduction to (unknown) reference:** What is possible is this. The virus concentration in the cabin can be halved (with 50% recirculation) if, in addition, recirculation with a 100% effective HEPA filter is used. $C = S / Q$.
- **HEPA filters may not exist or not work:** There are no binding requirements for the existence (some smaller aircraft do not have them) or the maintenance of HEPA filters in aircraft. Therefore, no information can be given about their quality in practice. But: Filtration efficiency may even improve, when filters are old and dirty.

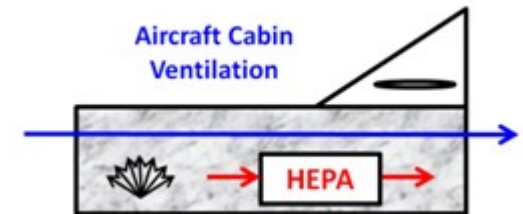

IATA:



<https://perma.cc/686X-X9AZ?type=image>

Legend or Truth?

Industry Claim 2:

The air in the aircraft is "**FULLY renewed every 2 to 3 minutes**"

- **Statement is irrelevant:** The air change rate is only important for dynamic processes (not relevant here!). $C = S / Q$.
- **Unfit parameter for comparison:** The air change rate, n in the aircraft is only so high because the volume V per passenger (about 2 m^3 on an airplane) is so small. This makes the air change rate, n unfit as a parameter for comparison with rooms where people have more volume each (office, cathedral, ...).
- **One air change in 3 minutes is wrong:** For 0.25 kg of air per minute and person and 2 m^3 per person, a cabin volume of fresh air must flow into the cabin at least every 6.7 minutes. Aircraft better than required? Manufacturers seem to use the "cabin volume" (volume above cabin floor) instead the "volume in the pressure seals" to calculate one theoretical air change in about 3 minutes.
- **Statement "fully" is wrong:** With optimal mixed ventilation (which is never the case in practice), the concentration of a substance is reduced to 37% of the original value after one air change. Only after 5 air changes does the concentration drop below 1% (assuming a ventilation efficiency of $\eta = 1$).

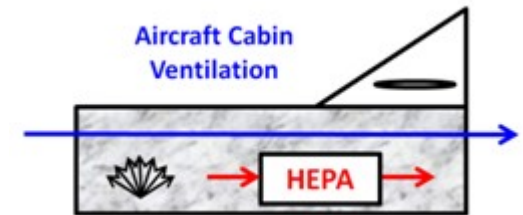

IATA:



<https://perma.cc/686X-X9AZ?type=image>

Legend or Truth?

Industry Claim 2:

The air in the aircraft is " **FULLY renewed every 2 to 3 minutes** "

No, see video: 5 air exchanges are necessary!



Video: <https://youtu.be/QYP255V03BY?t=544>

Legend or Truth?

Industry Claim 2:

The air in the aircraft is " **FULLY renewed every 2 to 3 minutes** "

Ventilation Comparison

Aircraft

versus

Home

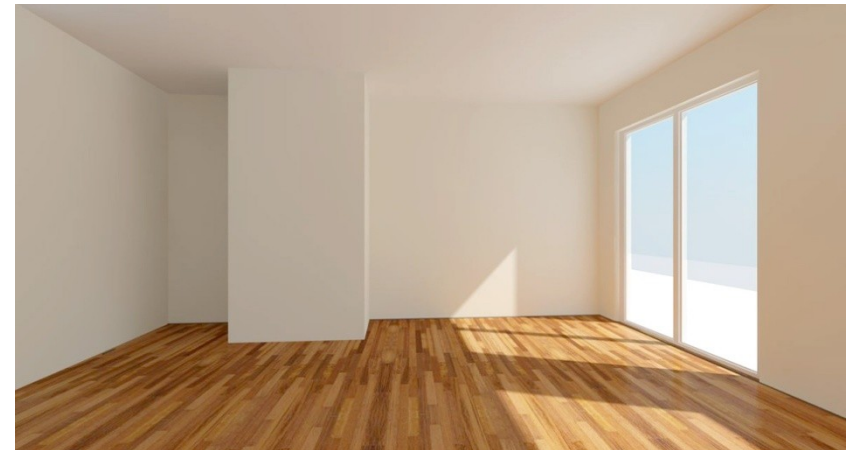

Ventilation rate: $Q = 18 \text{ m}^3/\text{h}$ (0.25 kg/min)
 Volume per person: $V = 2 \text{ m}^3$
 Air change rate: $n = Q / V = 18/2/\text{h} = 9/\text{h}$
 One air change in: $t = 6.7 \text{ min}$

$Q = 90 \text{ m}^3/\text{h}$
 $V = 36 \text{ m}^2 \cdot 2.5 \text{ m} = 90 \text{ m}^3$
 $n = Q/V = 90/90/\text{h} = 1/\text{h}$
 $t = 1 \text{ h} = 60 \text{ min}$

relevant value

irrelevant value

Ventilation rate in the (my) home is 5-times that of the aircraft!

Video: <https://youtu.be/QYP255V03BY?t=375>

Legend or Truth?

Industry Claim 3:

The **air flow** in the aircraft cabin "**only from top to bottom**" or "**no horizontal flow**" (not sideways, not forward or aft)

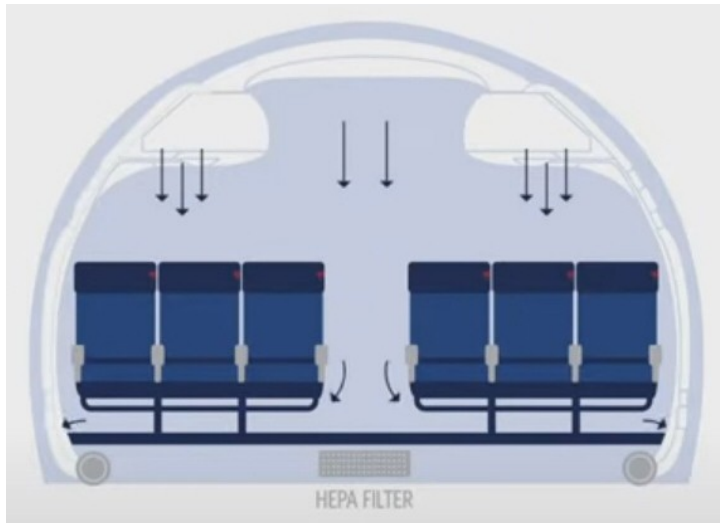

Delta: Video: https://youtu.be/ll-4LUfcr_s?t=33

Air flow only from top to bottom?
Cabin air ventilation out of the overhead bins?



Delta: Video: https://youtu.be/ll-4LUfcr_s?t=67



Legend or Truth?

Industry Claim 3:

The **air flow** in the aircraft cabin "**only from top to bottom**" or "**no horizontal flow**" (not sideways, not forward or aft)

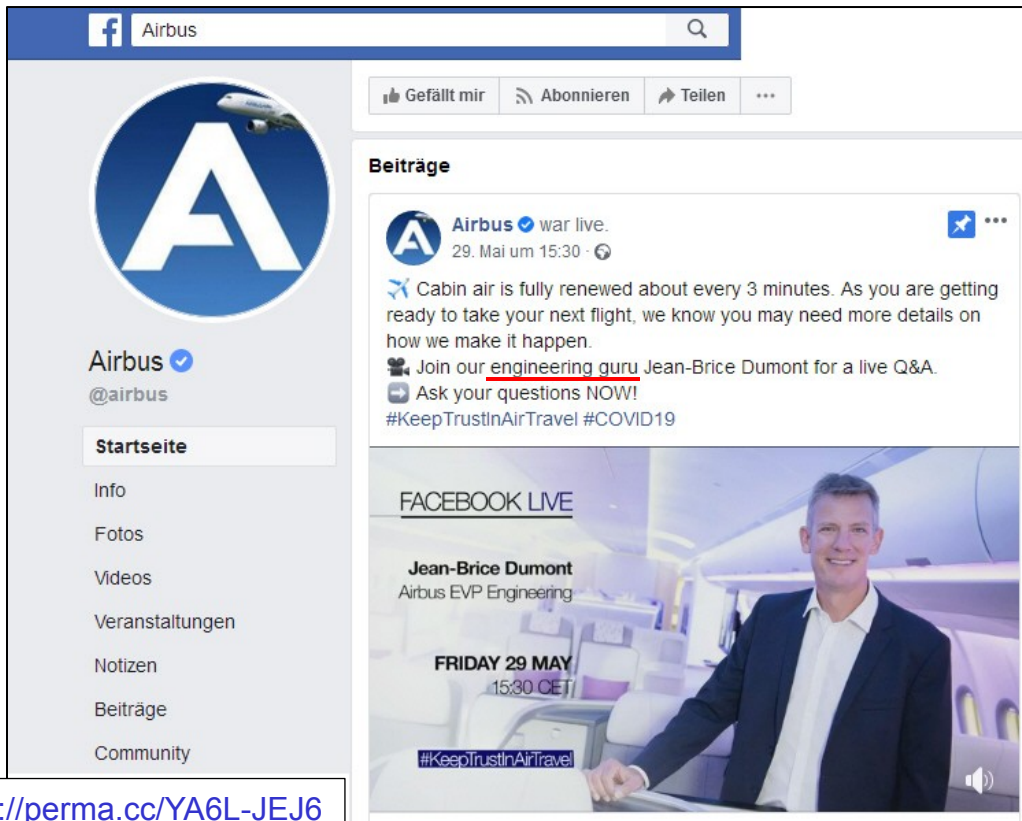

<https://perma.cc/YA6L-JEJ6>

Jean-Brice Dumont, Airbus ("guru"):
It [the air] flows from top to bottom at one meter per second, and is subsequently removed through the floor. This airflow is optimized to prevent longitudinal movement, so there is no spread between adjacent seat rows.

Facebook, 29.05.2020

Dieter Scholz:
Airbus' Cabin Air Explanations during the Corona Pandemic – Presented, Analyzed, and Criticized, Memo, 2020-06-19.
<https://doi.org/10.31224/osf.io/b9dkp>

<https://www.facebook.com/watch/?v=582384906021127>
 Video: <https://youtu.be/LV00dLUdK0k>

Legend or Truth?

Industry Claim 3:

The **air flow** in the aircraft cabin "**only from top to bottom**"

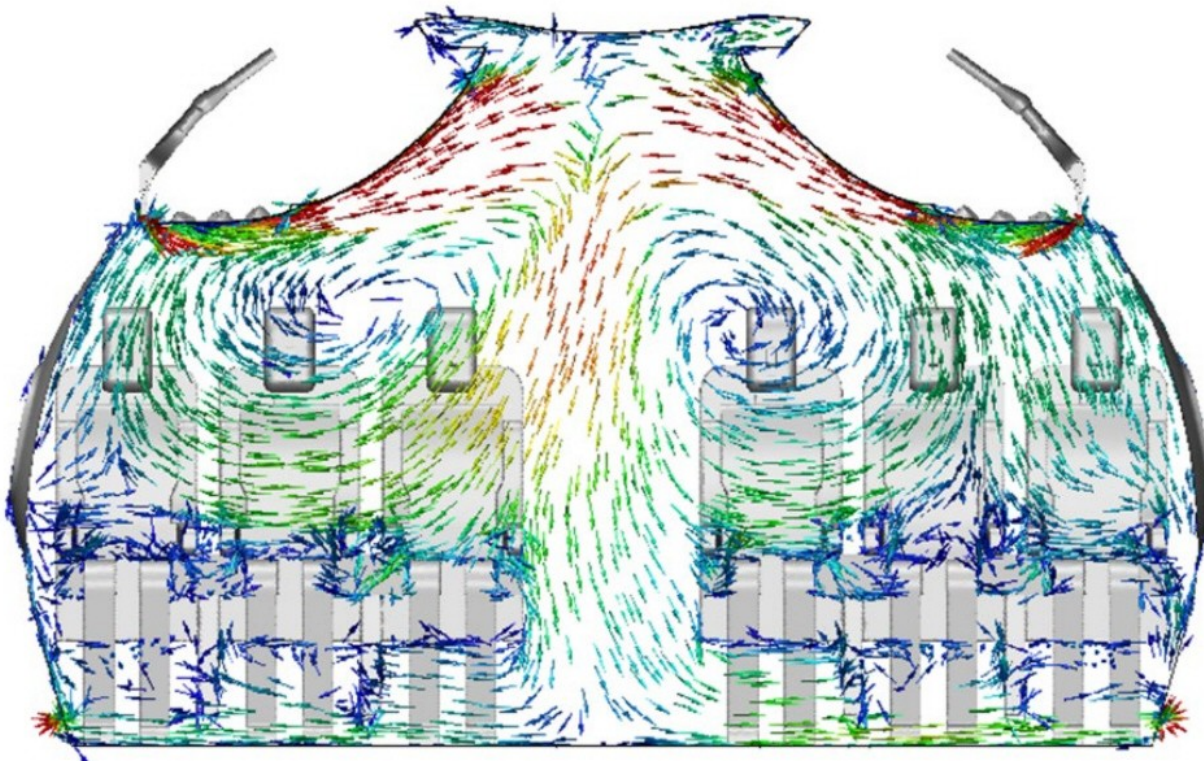

Flow direction indicated by the arrows show **flow from one passenger to the other** and as such the exchange of breathing air.

Nevertheless,

Boeing concludes:

"**the risk of contracting COVID-19 while flying is low.**"

Engineering controls on modern aircraft that employ high air flow from ceiling to floor, HEPA filtration, and set design / positioning that minimize air flow between rows, and play an important role in the control of particle fate in the cabin."

Source:

<https://perma.cc/S5VV-UNS2>

Boeing: CFD simulation of flow in a **B737** cabin cross section. Snapshot of a dynamic situation.

Legend or Truth?

Industry Claim 3:

The **air flow** in the aircraft cabin "**only from top to bottom**"

Explanations Given by Science:

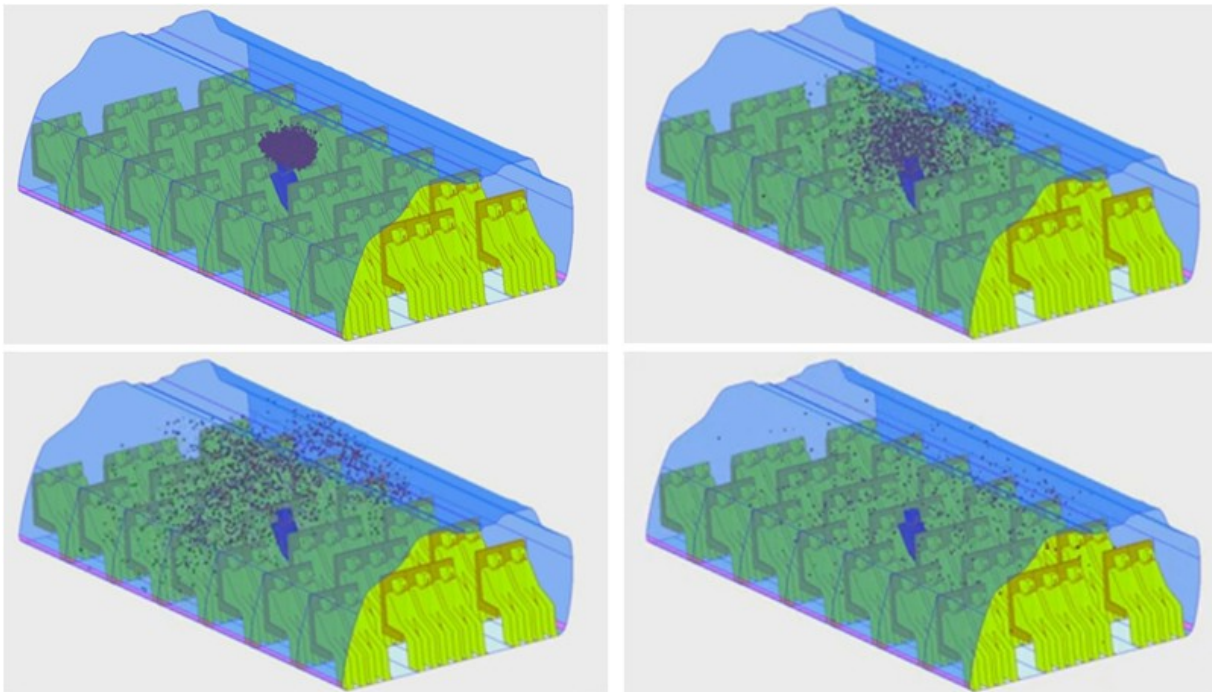

The special (unfavorable) case of the B767 was studied by Prof. Chen, Purdue University.

Video: <https://engineering.purdue.edu/~yanchen/infection.html>

Legend or Truth?

Industry Claim 3:

The **air flow** in the aircraft cabin "**only from top to bottom**"

Explanations Given by Science:

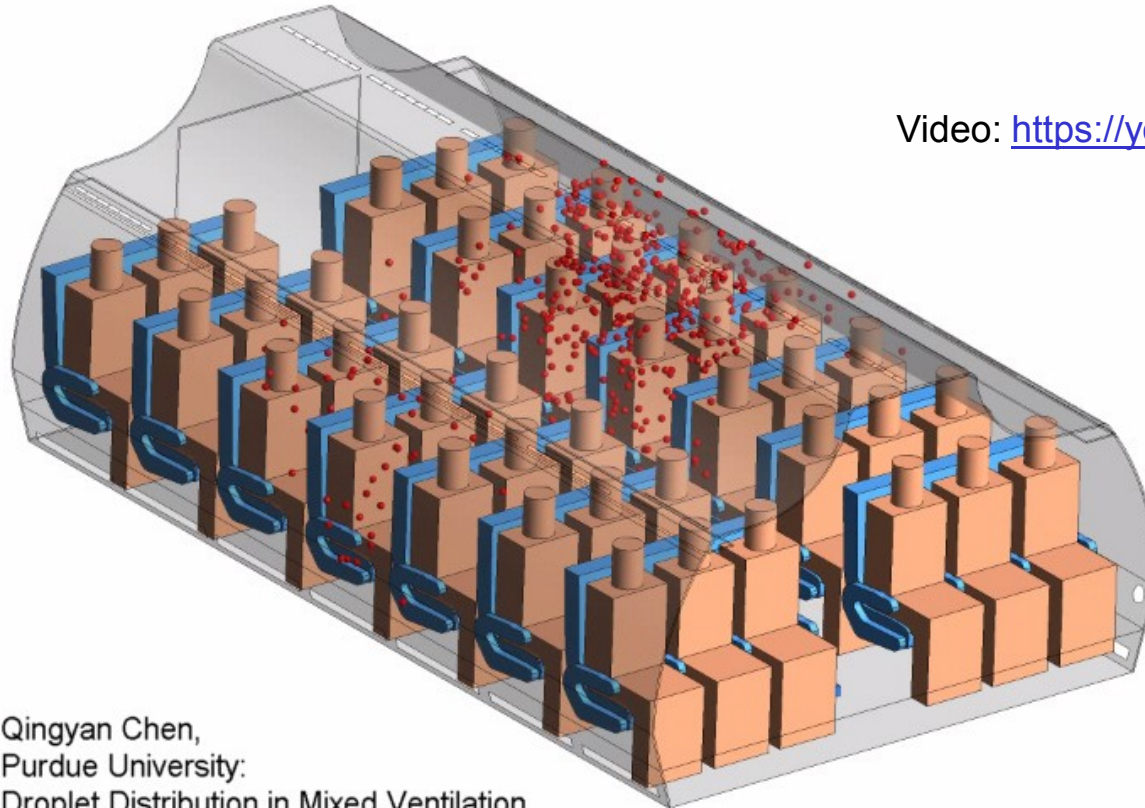

Video: https://youtu.be/t2QV5aqo_bl

Qingyan Chen,
Purdue University:
Droplet Distribution in Mixed Ventilation

Legend or Truth?

Industry Claim 6:

6 feet physical distancing minimum without a mask (CDC recommendation) **is equivalent to 1 foot distance onboard the aircraft** with a mask.

Scientific facts:

- **No airflow** that separates passengers.
- **No masks** are worn during extended periods (meals) during flight (especially in first class).

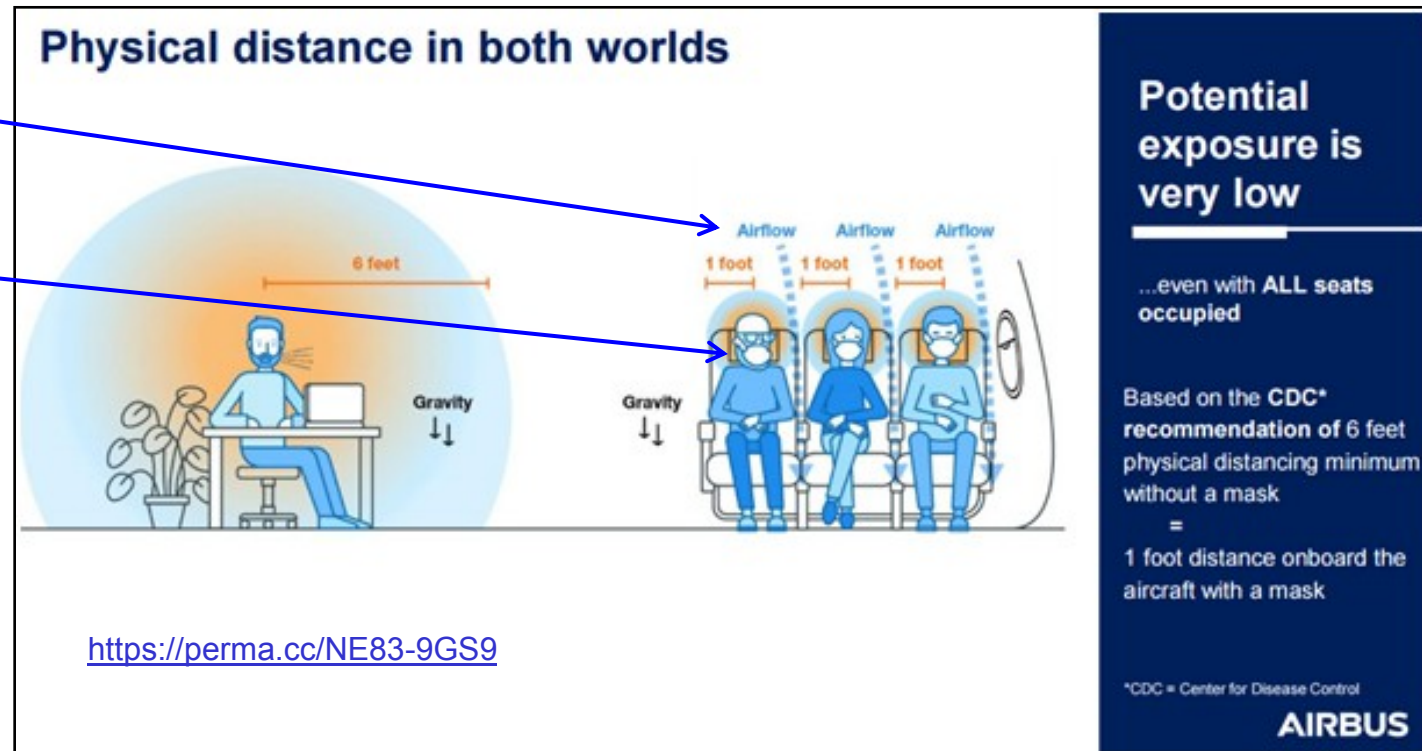



Legend or Truth?

Industry Claim 7:

"But with just 44 published cases of potential inflight COVID-19 transmission among 1.2 billion travelers, the risk of **contracting the virus on board appears to be in the same category as being struck by lightning**," said **Alexandre de Juniac**, IATA's Director General and CEO up to 2020. (<https://perma.cc/S29W-VDNM>)

However, 44 cases is just based on 13 studies (IATA: <https://perma.cc/Y2VV-ZJEM>), but this number divided by all passengers in 2020 is ... **'Bad math'** says Dr. David Freedman, a U.S. infectious diseases specialist.



 **REUTERS**

MON OCT 19, 2020 / 9:21 AM EDT

'Bad math': Airlines' COVID safety analysis challenged by expert

Laurence Frost

<https://perma.cc/8SWH-2BKD>

Clean bill of health

99.9%

Efficiency of HEPA filters used by environmental control systems of airliners in removing viruses from cabin air

With Covid-19 the spread is mainly caused by breathing in air when close to an infected person who is exhaling small droplets that contain the virus. By design, modern airliners have the upper hand here, as they are equipped with environmental control systems (ECS) that exchange the entire volume of cabin air for clean outside air every two to three minutes.

The ECS also contains High Efficiency Particulate Air (HEPA) filters – which the makers say provide hospital-grade 99.9% filtration efficiency, and effectively remove viruses like Covid-19. Airbus has fitted such filters to all its aircraft manufactured since 1994.

The number of reports of on board transmission is low, based on the number of published cases globally, Powell says. “The risk has proved, as we thought, to be low compared to other indoor spaces. You would expect that with controlled airflow, highly efficient filtration, mask wearing and everyone facing the same way [in their seats],” he says. “This is actually the less difficult of the two main problems to solve.”

A much harder problem is the issue of importation,

Legend or Truth?

IATA Does Not Give Up on the Topic

Flight International

September 2021



<https://perma.cc/64N4-JVEE>



Dr David Powell advises IATA and its members on Covid-19 measures

Truth Decay?

Right or Wrong Does Not Matter Anymore

Definitions from the book:

Disinformation

False or misleading information spread intentionally, usually to achieve some political or economic objective, influence public attitudes, or hide the truth. This is a synonym for propaganda.

"Fake news"

Newspaper articles, televisions news shows, or other information disseminated through broadcast or social media that are intentionally based on falsehoods or that intentionally use misleading framing to offer a distorted narrative

Social Media!

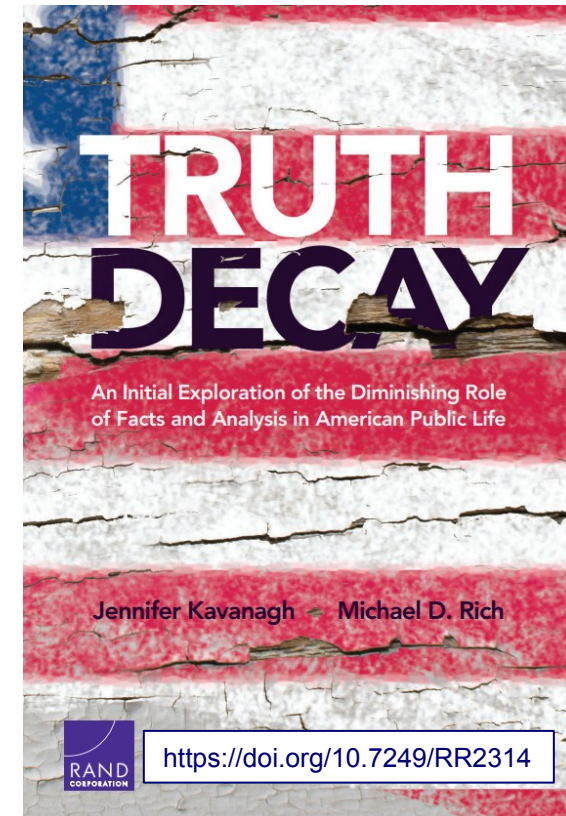

For more related information see:

SCHOLZ, Dieter, 2020. *Aviation Ethics – Growth, Gain, Greed, and Guilt*. German Aerospace Congress 2020 (DLRK 2020), Online, 01.-03.09.2020. Available from: <https://doi.org/10.5281/zenodo.4068009>

Truth Decay?

IATA Active on Facebook

Facebook

21 September 2020

<https://perma.cc/686X-X9AZ?type=image>

International Air Transport Association (IATA) ✓
Yesterday at 9:48 AM · 🌐

Air in an airplane ✈️ is cleaner than people think 🌿.
Here are 4 key reasons why 🙌
#FlySafe #ReadyToFly

HEPA filters in aircraft remove **99.9%** of viruses like COVID-19
Source: Pöhl Aerospace

Cabin air is as clean as a **hospital operating theatre**

Cabin air is **fully renewed** every 2-3 minutes
Hospitals ≈ 10 minutes
Offices ≈ 20 minutes

Cabin air quality is a **50/50 mix** of fresh air and recirculated HEPA filtered air.
Air is fully renewed 20-30 times per hour.

706 42 Comments 1.3K Shares

AIRCRAFT DESIGN AND SYSTEMS GROUP (AERO)

Review of CO₂ Reduction Promises and Visions for 2020 in Aviation

Dieter Scholz

Hamburg University of Applied Sciences

<https://doi.org/10.5281/zenodo.4066959>

Deutscher Luft- und Raumfahrtkongress 2020

German Aerospace Congress 2020

Online, 01 - 03.09.2020

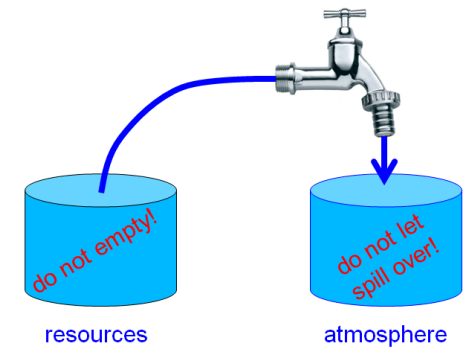
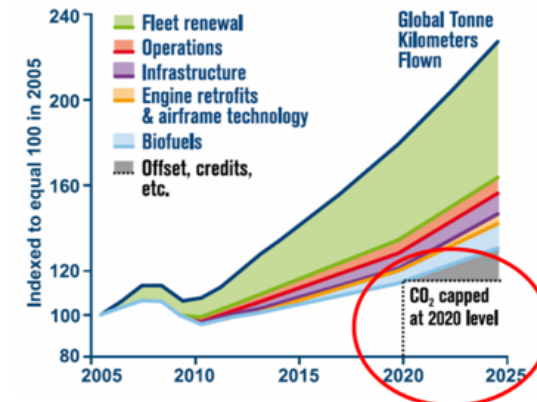

Motivation

**Do not tell me today
what you will have achieved in x years.**

**Tell me what you told x years ago and
how much of that you achieved today!**

Dr. Dieter Dey, Airbus, 1988

Motivation



13 NOVEMBER, 2019 | SOURCE: FLIGHTGLOBAL.COM | BY: DAVID KAMINSKI-MORROW | LONDON

Wizz Air chief Jozsef Varadi has scorned the pledges of airlines which are committing to becoming carbon-neutral in several decades' time.

"It's great when an airline like **British Airways**, **KLM**, or **Air France** says that in 2050 – we're all going to be dead by that time – we're going to be carbon neutral," he said. "These are the worst-performing airlines."

Promises and Visions for 2020

The year **2020** is pivotal when it comes to environmental goals:

- **ACARE**: European Aeronautics – A Vision for **2020**:
"A 50% cut in fuel consumption in the new aircraft of 2020"
compared to 2000
- **IATA**: Carbon-neutral growth from **2020**
- **ATAG**: Carbon-neutral growth from **2020**
- **ICAO**: CORSIA: "the basis for carbon neutral growth from **2020**"

ACARE: A Vision for 2020

The "Group of Personalities" in 2020:

Pedro Argüelles: 1950 (age 70 years)
Manfred Bischoff: 1942 (age 78 years)
Philippe Busquin: 1941 (age 79 years)
Sir Richard Evans: 1942 (age 78 years)
Walter Kröll: 1938 (age 82 years)
Jean-Luc Lagardère: * 1928, † 2003
Denis Ranque: 1952 (age 68 years)
Paul Reutlinger: * 1943, † 2010
Sir Ralph Robins: 1932 (age 88 years)
Helena Terho: 1948 (age 72 years)
Arne Wittlöv: 1940 (age 80 years)



An average age of 77 years (if still alive)

Could we hold them accountable?

No, because no legal contract!

Group of Personalities

Pedro Argüelles

John Lumsden

Manfred Bischoff

Denis Ranque

Philippe Busquin

Soren Rasmussen

B.A.C. Droste

Paul Reutlinger

Sir Richard Evans

Sir Ralph Robins

Walter Kröll

Helena Terho

Jean-Luc Lagardère

Arne Wittlöv

Alberto Lina

IATA: CNG from 2020

IATA: International Air Transport Association.
A trade association of airline companies.

IATA , 2009: A global approach to reducing aviation emissions. First step: carbon-neutral growth from 2020. – URL:
<http://www.iata.org/whatwedo/environment/Documents/global-approach-reducingemissions.pdf>

IATA Deleted this Document

Archived at: <https://perma.cc/42HW-ZTKF>

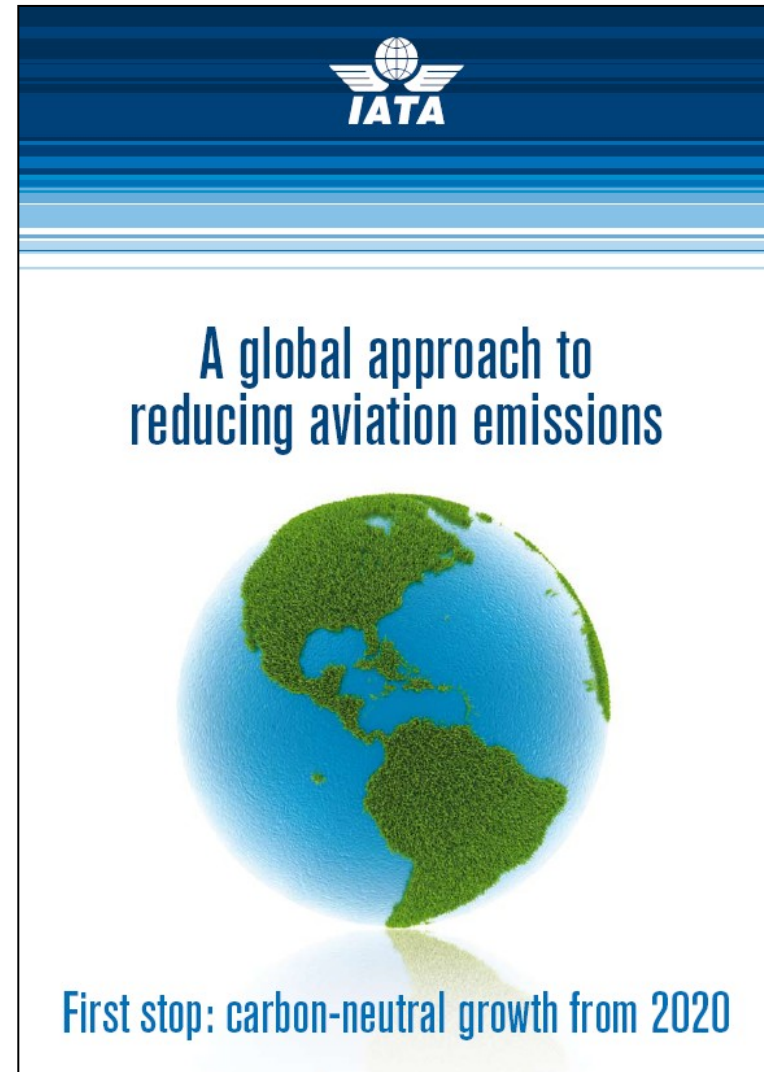

IATA: CNG from 2020

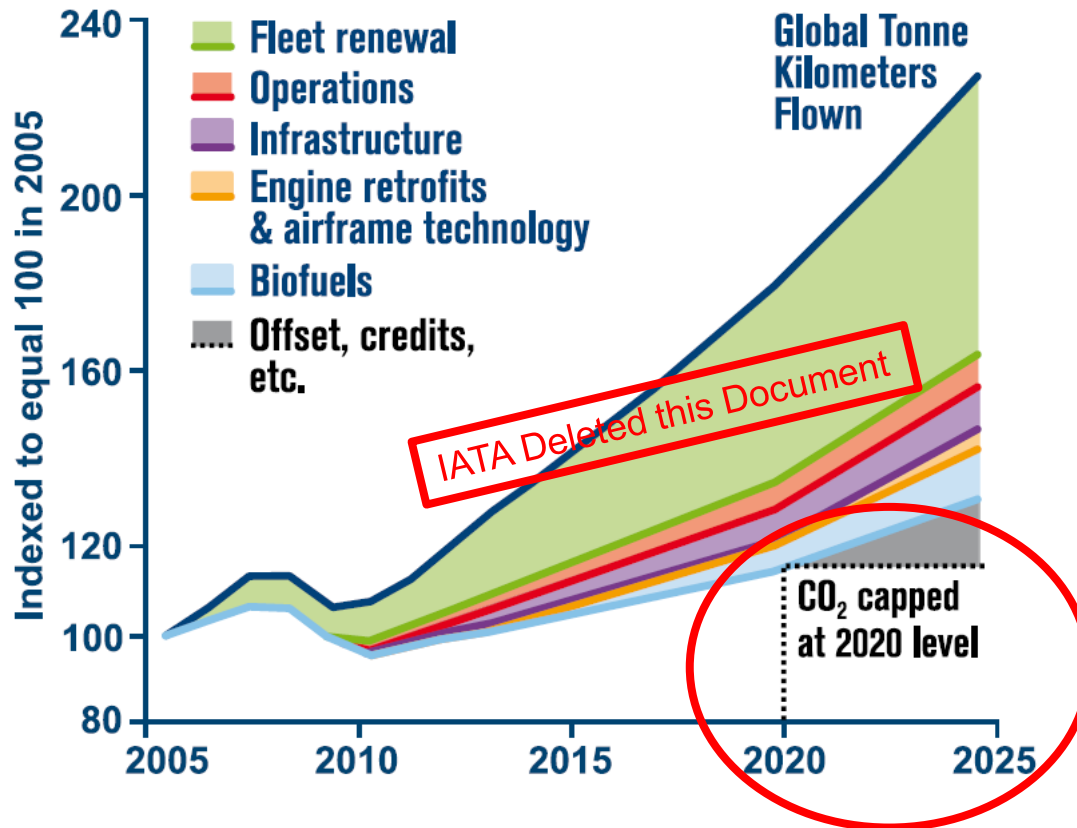

2020 is **arbitrary** to start with CO₂ compensation.

Compensation could have started earlier.

Why not postpone longer?

Did we notice any change with the 2020 CO₂ cap?

IATA (and ATAG) want to achieve zero emission growth from 2020 onwards. This is only possible with CO₂ compensation (carbon **offset schemes**).

Archived at: <https://perma.cc/42HW-ZTKF>

IATA: CNG from 2020

Carbon-Neutral Growth from 2020: IATA'S FOUR-PILLAR STRATEGY

Pillar 1 – technology

IATA Deleted this Document

A320: 1988: reference
 A320neo: 2016: fuel burn: -15%
 15% in 28 years

This is: 11% in 20 years
 Much less than 50% in 20 years (ACARE)

Archived at: <https://perma.cc/42HW-ZTKF>

Timelines and examples of technologies 2009-2020	Impact
Retrofits	7-13%
<ul style="list-style-type: none"> Winglets mounted on the wingtips of aircraft improve aerodynamics and reduce fuel burn More advanced engine components for better combustion and airflow Lighter materials for furnishing in the cabin Less energy-consuming lighting and in-flight entertainment 	1-4%
Production Updates	7-18%
<ul style="list-style-type: none"> More airframe structure components made of lightweight composite material instead of aluminium Advanced engines for current aircraft production series 	???
New aircraft design before 2020	25-35%
<ul style="list-style-type: none"> Geared turbofan engine will reduce fuel burn 10-15% Open rotor engine will reduce fuel burn around 25% Counter-rotating fan will reduce fuel burn 10-15% Advanced turbofan will reduce fuel burn around 15% Laminar flow reduces aerodynamic drag by reducing turbulence on aircraft surface, 10-15% less fuel burn 	ok ??? ??? ??? ???
New aircraft design after 2020	25-50%
<ul style="list-style-type: none"> Blended wing body, rather than the classical tube-and-wing architecture Revolutionary engine architectures Fuel cell system for on-board energy 	no ??? no

ATAG: CNG from 2020



Our climate targets:

1.5%

We will improve our fleet fuel efficiency by 1.5% per annum between now and 2020.

Stabilise

From 2020, net carbon emissions from aviation will be capped through carbon neutral growth.

50%

By 2050, net aviation carbon emissions will be half of what they were in 2005.

 Angela Gittens Director General		 Paul Riemens Chairman of the Executive Committee		 Tony Tyler Director General and CEO	
 Marion C. Blakely Chair		 Thomas Enders President and CEO		 Jim Albaugh President and CEO	
 Filippo Bagno Chief Executive Officer		 Guy Hachey President and COO Bombardier Aerospace		 THE POWER OF FLIGHT Jean-Paul Ebanga President and CEO	
 Paulo Cesar de Souza e Silva President Commercial Aviation		 David Joyce President and CEO GE Aviation		 Tim Mahoney President and CEO Honeywell Aerospace	
 John Saabas President Pratt & Whitney Canada		 Eric Schulz President – Civil Large Engine Programmes		 Paul Steele Executive Director	

6th Aviation & Environment Summit, 22 March 2012

<https://www.atag.org/facts-figures.html>

Comparison of Goals

Flight International, 2014-01-14:

RESEARCH

2020 CARBON NEUTRAL GOAL INSUFFICIENT TO TACKLE RISING EMISSIONS

... according to Manchester Metropolitan University's Centre for Aviation, Transport and the Environment (CATE) ... because **CO2 accumulates faster in the atmosphere than it can be removed**. Therefore **CO2 output must be reduced!** IATA: "The science is so uncertain that we really wouldn't know what to do". **Russia** on the other hand **does not even want carbon neutral growth (CNG)!**



Comparison of Goals

With carbon neutral growth (CNG) the tap is left wide open.

Maybe it is time to close the tap a least a little?

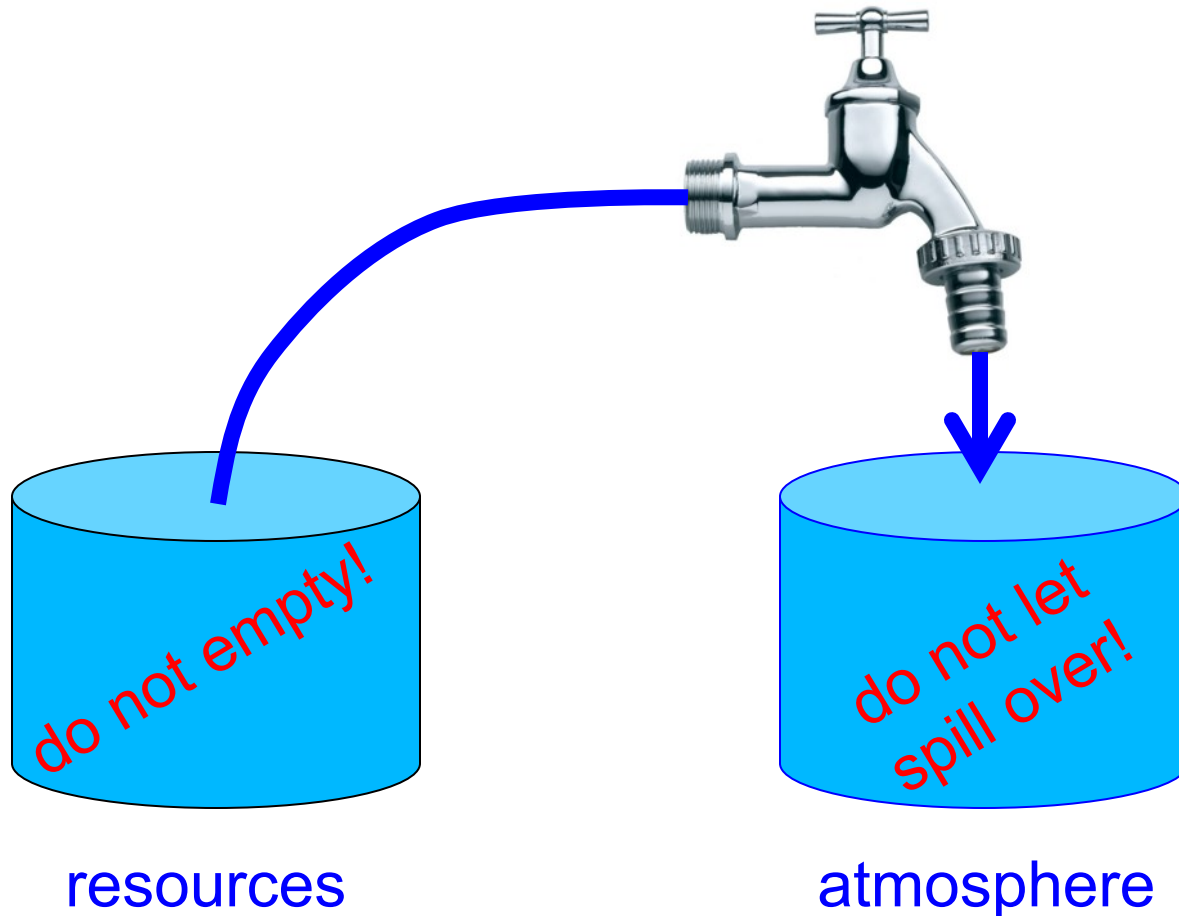

Summary – Goals, Promises and Visions **Today**

- **Goals, Promises and Visions** are **used to improve conditions in business**:
 - receive money or reduce payments,
 - avoid or delay unwanted legislation (work slowly!).
- Goals, Promises and Visions **need to be distributed** and **directed to politics**:
 - lobbying, media, research publications.
- Goals, Promises and Visions **need to be irresistible**:
 - supported by VIPs, signatures and logos,
 - supported by technical details supported by experts.
- Goals, Promises and Visions **should have a long time horizon**:
 - discussions about fulfillment are postponed,
 - those who have given the promise are retired or dead.
- Goals, Promises and Visions **can be deleted or replaced**:
 - when their time of fulfillment comes near,
 - when circumstances have changed.

AIRCRAFT DESIGN AND SYSTEMS GROUP (AERO)

SONDERVORTRAG zum 50. Geburtstag der DGLR Bezirksgruppe Hamburg:

Design of Hydrogen Passenger Aircraft – How much "Zero-Emission" is Possible?

with backup slides

Dieter Scholz

Hamburg University of Applied Sciences

Hamburg Aerospace Lecture Series (AeroLectures)

DGLR, RAeS, VDI, ZAL, HAW Hamburg

Online, 19 November 2020

<https://doi.org/10.5281/zenodo.4301103>

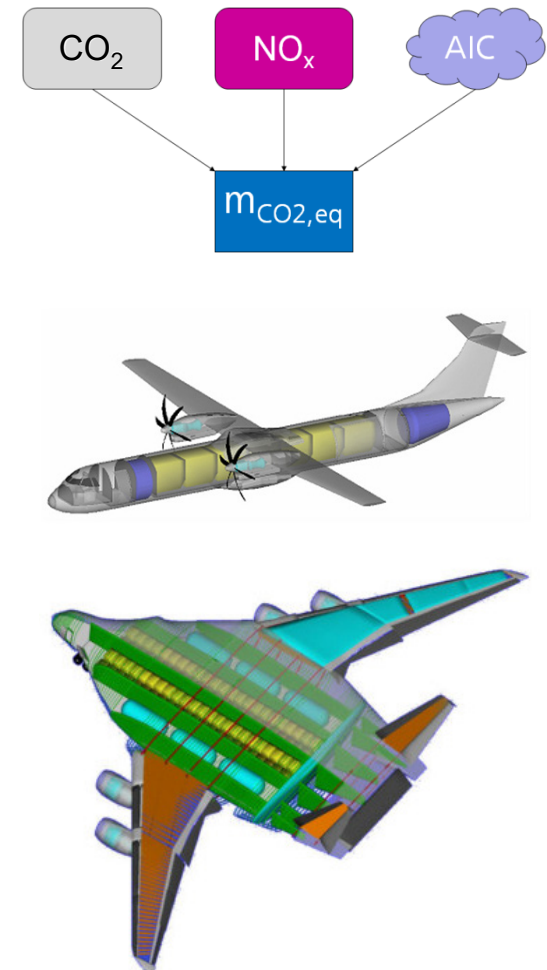

Airbus: "Zero-Emission" Hybrid-Hydrogen Passenger Aircraft



<https://www.airbus.com/innovation/zero-emission/hydrogen/zeroe.html>

Archived at: <https://perma.cc/HJ6L-3HUB>

"At Airbus, we have the ambition to develop the world's first zero-emission commercial aircraft by 2035."
(2020-09-21)

Airbus First? Tu-155 First Experimental Hydrogen Aircraft

ЭКСПЕРИМЕНТАЛЬНЫЙ САМОЛЕТ ТУ-155

Tu-155 was the first experimental aircraft in the world operating on hydrogen.

First flight was on 15 April 1988.

○ Hydrogen blow-off

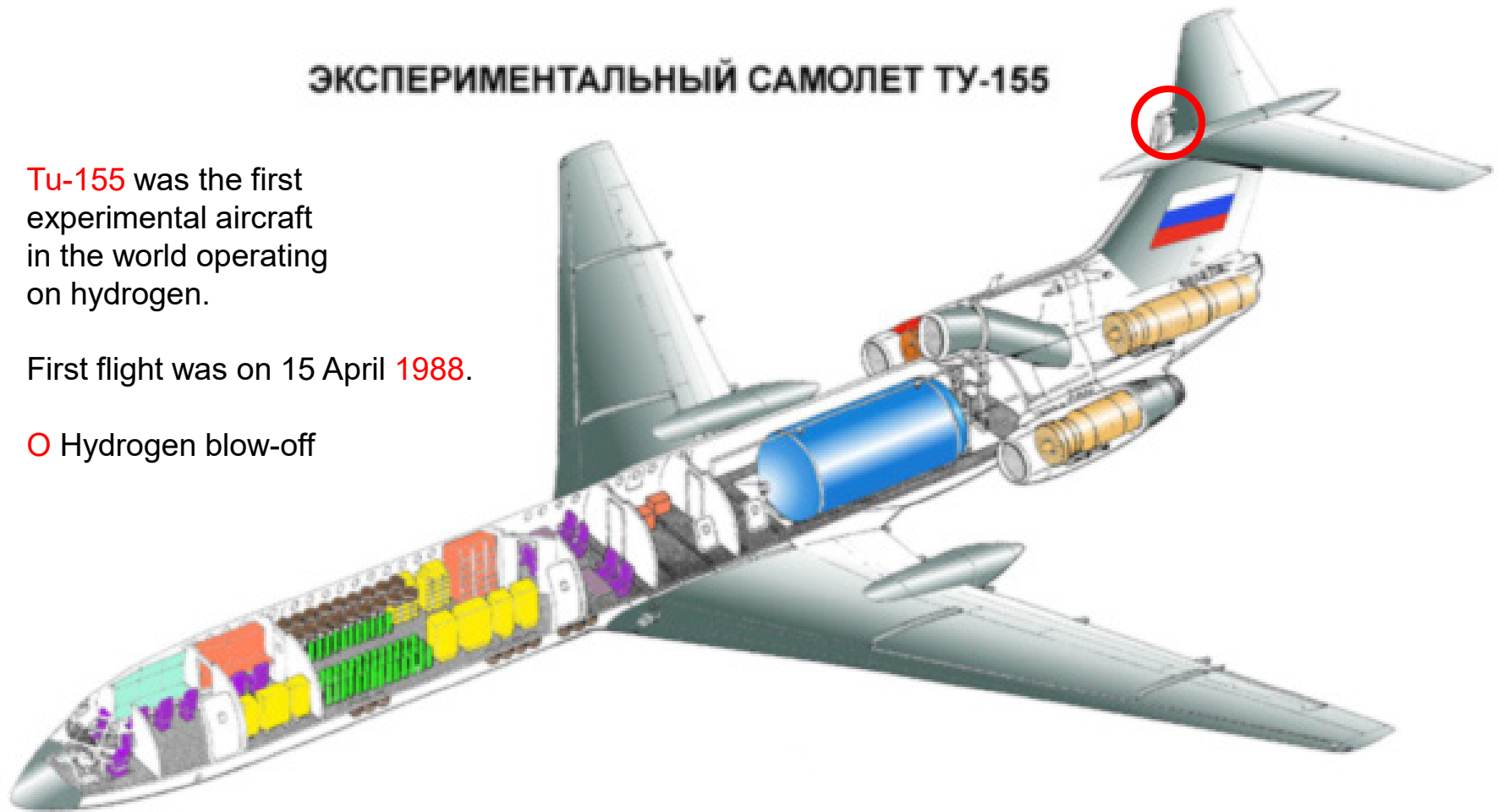

<https://web.archive.org/web/20120213180146/http://www.tupolev.ru/English/Picture.asp?PubID=1788>

Airbus First? First Passenger Hydrogen Fuel Cell Aircraft

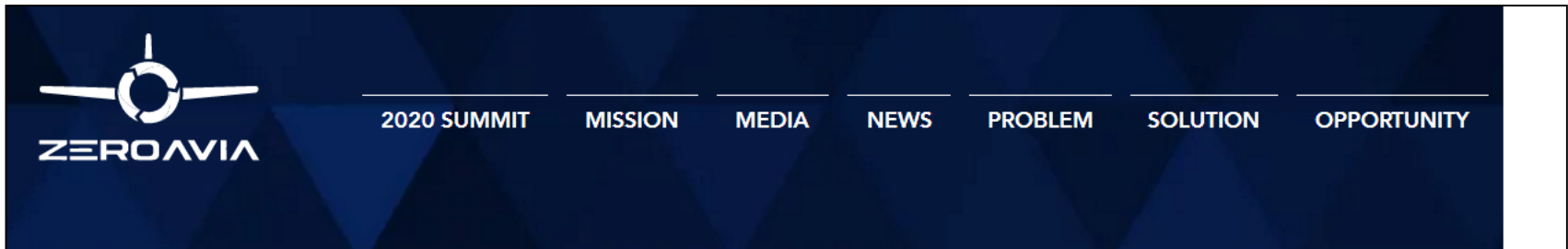

2020 SUMMIT
MISSION
MEDIA
NEWS
PROBLEM
SOLUTION
OPPORTUNITY

ZeroAvia Completes World First Hydrogen-Electric Passenger Plane Flight

25 September, 2020, 08:00 BST

- Leading innovator in the decarbonisation of aviation makes major breakthrough with first hydrogen fuel cell flight of a commercial-size aircraft.
- ZeroAvia's retrofitted Piper M-class is now the largest hydrogen powered aircraft in the world.

<https://www.zeroavia.com/press-release-25-09-2020>

Archived at: <https://perma.cc/K2G4-XEJP>

ZeroAvia Hydrogen Fuel Cell Flight

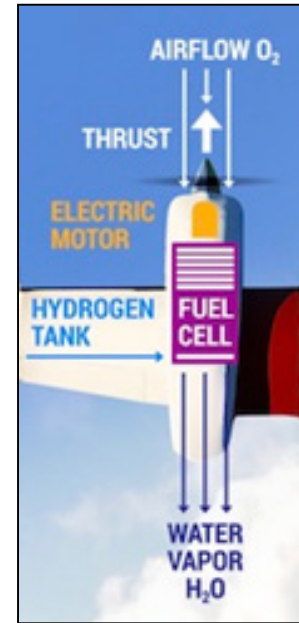

ZeroAvia's hydrogen powered Piper



<https://www.zeroavia.com/press-release-25-09-2020>

<http://sustainableskies.org/zeroavia-first-out-gate-h2>

Interior of a Piper M350 (<https://www.piper.com>)

Airbus: The Schedule Towards 2035



<https://youtu.be/LJGMLoSctZY>

Airbus: A **full-scale aircraft prototype** is **estimated** to arrive by the **late 2020s**.

<https://www.airbus.com/newsroom/stories/these-new-Airbus-concept-aircraft-have-one-thing-in-common.html>
 Archived at: <https://perma.cc/33W7-BBY6>

History of "Zero Emission" – The Logic of Political Goal Setting

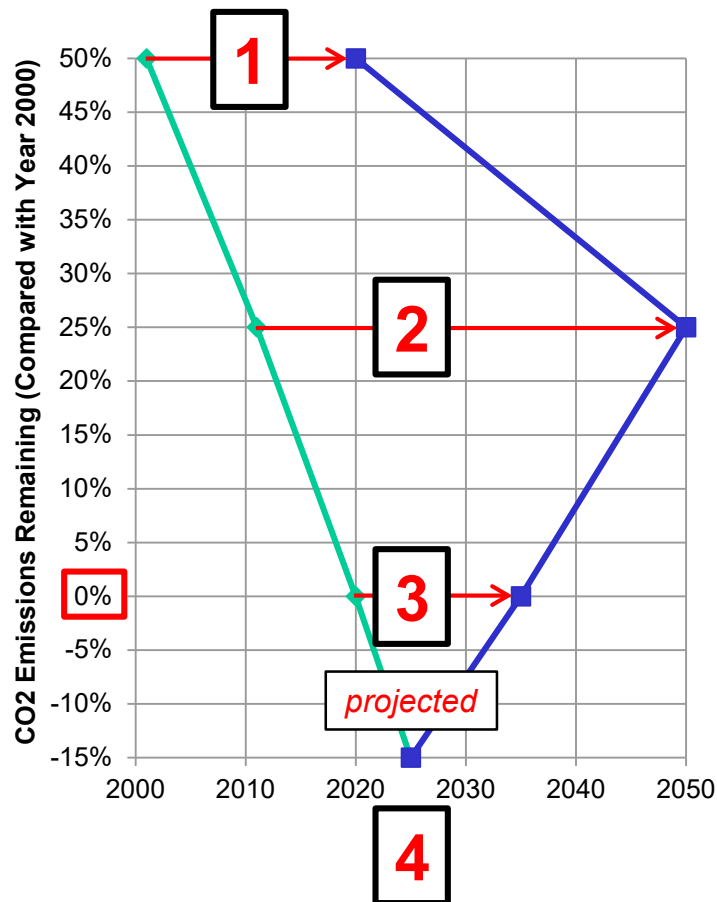

- 1: ACARE: Vision 2020
- 2: ACARE: Flightpath 2050
- 3: Airbus, DLR*, ...: Zero Emission
- 4: Hypothetical, if political trend continues

* DLR, BDLI, 2020-11-14: Zero Emission Aviation.
 Archived at: <https://perma.cc/M5VN-HG3Z>

—●— Announced
 —■— Achieved



Goal setting is linked to asking for public money:

- If money came for goal #n, a goal #n+1 has to be proclaimed as the base for a new requests for more money.
- Goal #n+1 needs to surpass goal #n in terms of reduction percentage and in an ever shorter time frame for its achievement.
- Goal #n+1 is proclaimed before goal#n has been reached.

Airbus: "Zero-Emission"?



Beware! **"Zero-emission" is never possible**; not for aircraft, not for animals/humans (CO₂, CH₄).

Airbus: *By 2035, the world's first zero-emission commercial aircraft could [or could not] take to the skies. To bring this vision to reality, Airbus is exploring [not: developing and building] game-changing concept aircraft – known as ZEROe – powered by hydrogen, a disruptive zero-emission technology [note: the technology is zero-emission not the aircraft] with the potential [but not necessarily the capability] to reduce aircraft emissions by up to 50%. [1]*

What is meant? "zero-emission aircraft" or only "reduce aircraft emission by up to 50%"?

What is meant? "zero-emission aircraft" or only "zero-emission technology"?

[1] <https://www.airbus.com/newsroom/stories/these-new-Airbus-concept-aircraft-have-one-thing-in-common.html>
Archive at: <https://perma.cc/33W7-BBY6>

Airbus: "Zero-Emission" – Corporate Statements

"At Airbus, we are convinced that carbon-neutral aviation is ... achievable." [1]

When?/What? What is "carbon-neutral aviation"? Is it "**carbon-neutral growth (CNG)**"? This is due in 2020, but is not achieved (or only due to the Corona pandemic). So it must be "**no carbon**" or "**a closed carbon cycle**" making carbon (CO₂) emissions "neutral".

"... it is estimated that hydrogen has the potential to reduce aviation's CO₂ emissions by up to 50%." [2]

"50%" is not "carbon-neutral aviation". How to achieve "**carbon-neutral aviation**", if **50% CO₂ is still emitted**?

Please compare with the statement on previous page: "reduce aircraft emissions by up to 50%" versus "reduce aviation's CO₂ emissions by up to 50%". "**aircraft emissions**" or "**aviation's emissions**"? "**emissions; 50%**" or "**CO₂ emissions; 50%**"?

"This is why we have the ambition to develop the world's first zero-emission commercial aircraft by 2035." [1]

"**Zero-emission**" by **only reducing CO₂** by 50%? Aviation's emissions are more than only CO₂.

We do not have a CO₂ problem. We have a water problem!

"All three ZEROe [**zero-emission**] concepts are ... powered by **hydrogen combustion**." [3]

"Zero-emission" is linked to an aircraft's "hydrogen combustion". This is far from true!

[1] <https://www.airbus.com/company/sustainability/environment/decarbonisation.html>

Archived at: <https://perma.cc/58TL-YKCC>

[2] <https://www.airbus.com/innovation/zero-emission/hydrogen.html>

Archived at: <https://perma.cc/AM2K-4C9Q>

[3] <https://www.airbus.com/innovation/zero-emission/hydrogen/zeroe.html>

Archived at: <https://perma.cc/HJ6L-3HUB>

Airbus: "Zero-Emission" – Interesting Personal Statements

Glenn Llewelyn (Vice President Head of Zero Emission Aircraft, Airbus):

We make sure that there are no non-CO2-effects when we use hydrogen onboard the aircraft. It's not all resolved in terms of the solution and the details. We have a road map ... to secure our ambition to zero emission. Very clearly we see that hydrogen has the potential ... has some work to do but [hydrogen] is really the most promising vector to deliver ultimately zero emission flight. [1]

Dr. Sandra Bour-Schaeffer (Head of Airbus Group Demonstrators, CEO of Airbus UpNext):

We will be producing more vapor and probably more contrails ... Yes there remain open questions we have to look on and contrails are one of them. [2]

Glenn Llewelyn:

As recently as five years ago, hydrogen propulsion wasn't even on our radar as a viable emission-reduction technology pathway. Today, we're excited by the incredible potential hydrogen offers aviation in terms of disruptive emissions reduction. [3]

[1] Introducing #ZEROe, 2020-09-21,
https://youtu.be/525YtyRi_Vc (22:22)

[2] Decarbonising Aviation. Royal Aeronautical Society Corporate Partner Briefing, 2020-11-05, <https://youtu.be/LJGMLoSctZY> (24:30)

[3] <https://www.airbus.com/newsroom/stories/these-new-Airbus-concept-aircraft-have-one-thing-in-common.html>,

Archived at: <https://perma.cc/33W7-BBY6>

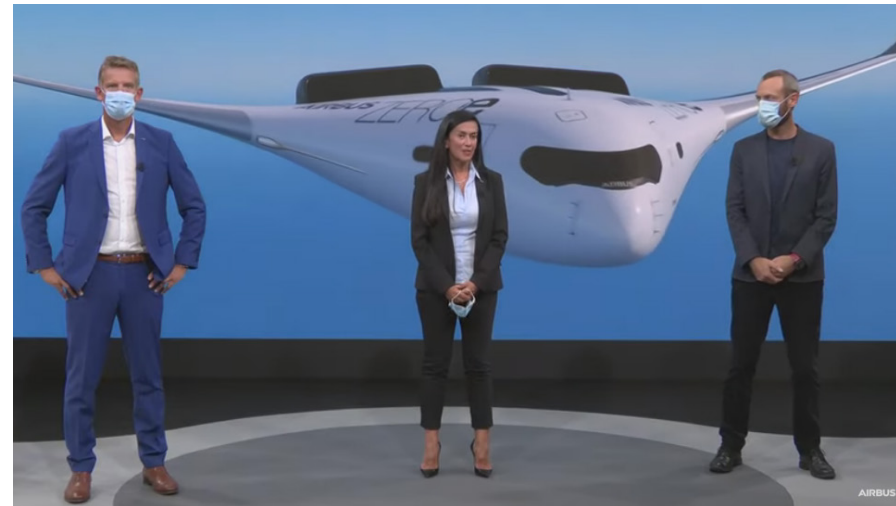

Introducing #ZEROe, https://youtu.be/525YtyRi_Vc. Left to right: Jean-Brice Dumont (Executive Vice President Engineering, Airbus), Grazia Vittadini (Chief Technology Officer, Airbus), Glenn Llewelyn (Vice President Head of Zero Emission Aircraft, Airbus).

AIRBUS

Commercial Aircraft Helicopters Defence Space Innovation Company Media [Airbus Home](#) > [Company](#) > [Sustainability](#) > [Environment](#) > [Decarbonisation](#)

Decarbonisation

Towards more sustainable air travel for future generations

<https://www.airbus.com/company/sustainability/environment/decarbonisation.html>

Archived at: <https://perma.cc/58TL-YKCC>

**Decarbonisation means reducing CO₂, but
aviation emissions is more than CO₂!**

EU-Study, May 2020



<https://doi.org/10.2843/471510>
 Archived at: <https://perma.cc/BJJ6-5L74>

AIRBUS and many others

Emissions

Average values	CO ₂	NO _x	Water vapor	Contrails	Total
Kerosene	100%	100%	10%	100%	310%
Synfuel	0%	100%	10%	75%	185%
H₂ turbine	0%	35%	25%	60%	120% ≠ 0%
H ₂ fuel cell	0%	0%	25%	30%	55%

Energy / Primary Energy

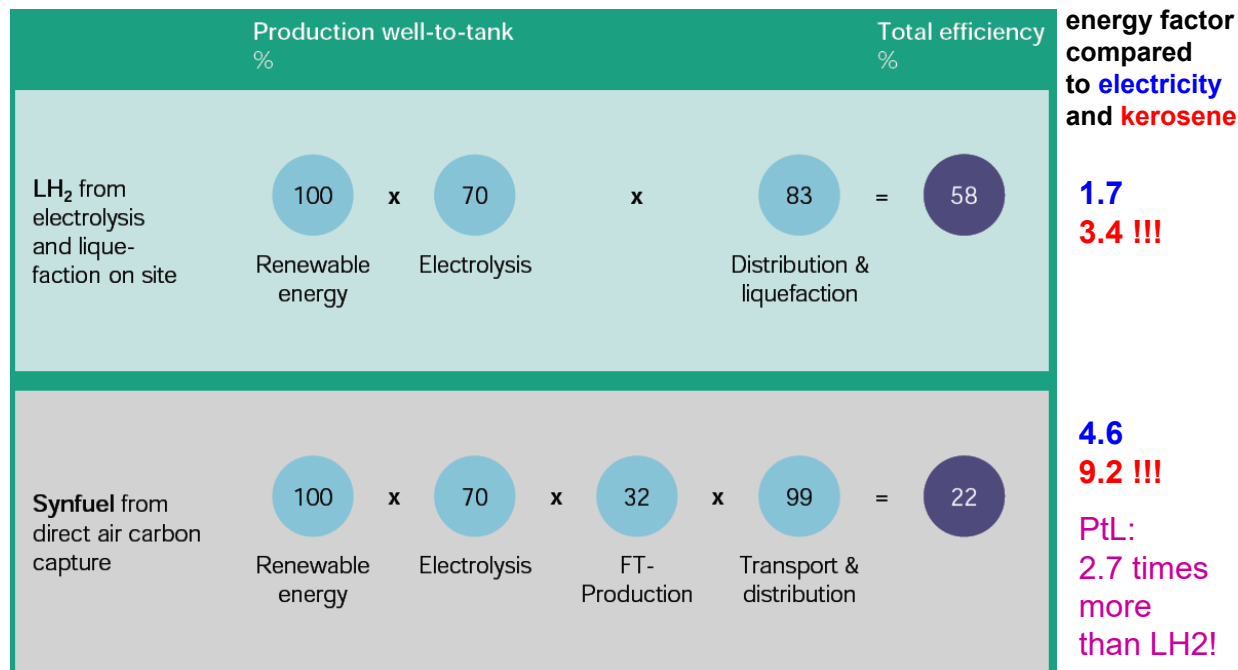

Refueling an A350 Once per Day Can Be Done with 52 Big Wind Power Plants (4.6 MW Each)

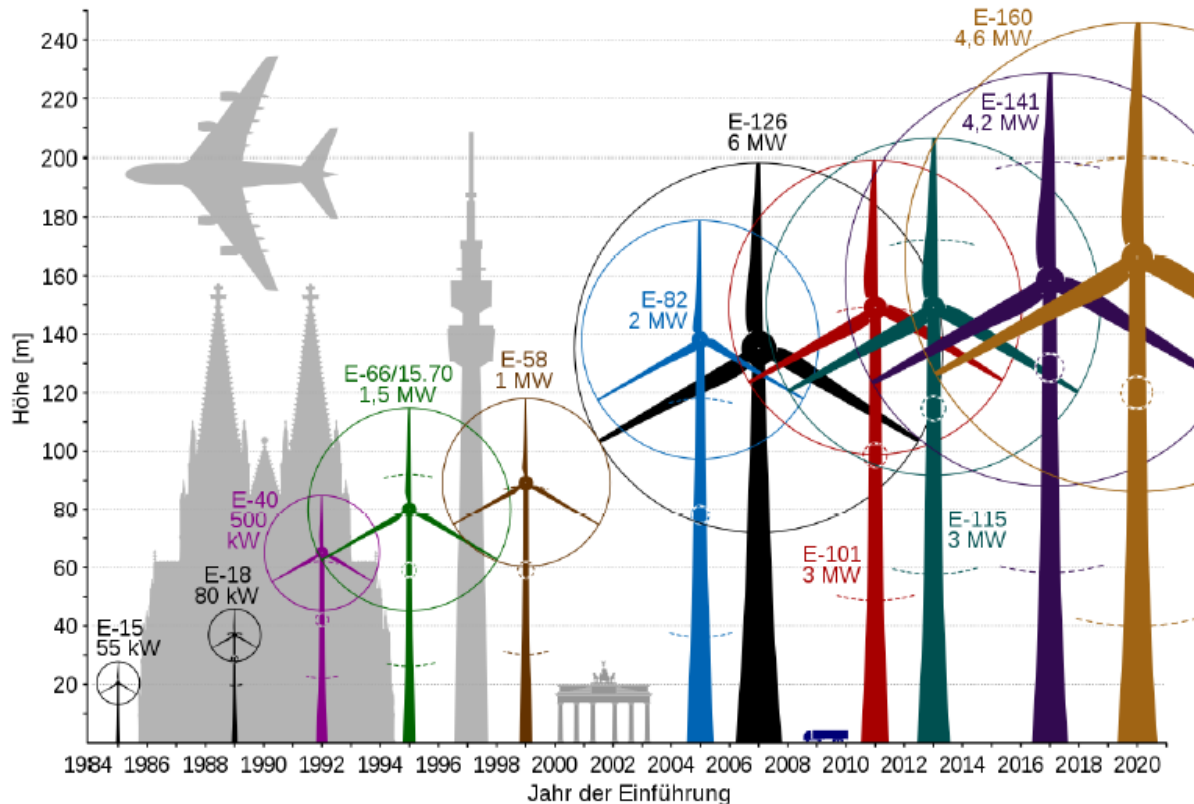

Airbus A350-900:
 Kraftstoffkapazität: 138.000 L
1x Volltanken pro Tag
 entspricht
52x E-160 4,6 MW
 (Annahmen: CF=50%, $\eta_{PIL} = 0.45\%$)

Electric Propulsion at Airbus – Limited Success

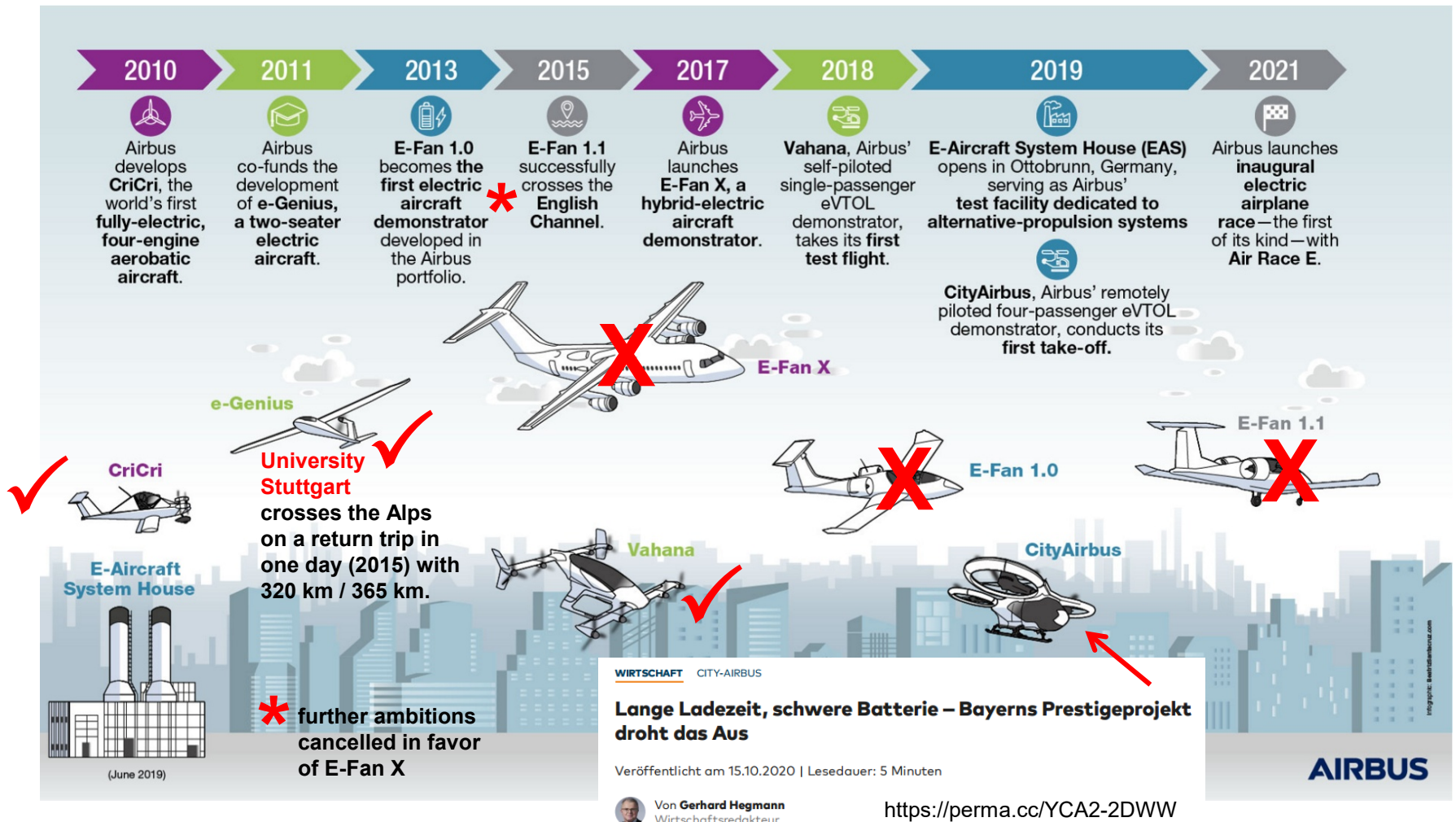

Modern Aviation Vocabulary

- a giant leap (for mankind; Neil Armstrong when setting foot on the moon)
- to rise to the challenge
- seismic shift
- game-changing
- (bold) vision
- revolutionary design
- disruptive technology (braking with the traditional way e.g. of technology)
- (there is no) silver bullet (simple solution to a complicated problem)
- crystal ball (forecasting the future)
- the entire aviation ecosystem
- ...

Corona, Politics, and Lots of Money Behind ZEROe

9-Jun-2020 12:07 PM

CORAC to receive EUR1.5bn over three years to research carbon neutral aircraft

<https://centreforaviation.com/news/corac-to-receive-eur15bn-over-three-years-to-research-carbon-neutral-aircraft-1003496>

Archived at: <https://perma.cc/9WEM-TGAV>

The French government has earmarked 1.5 billion euros for the development of carbon-free aircraft as part of a support plan for the aviation sector, which has been brought to its knees by the fallout from the coronavirus pandemic. Overall, France is planning to invest 7 billion euros in the development of hydrogen solutions, with neighboring Germany setting aside 9 billion.

<https://www.dailysabah.com/business/transportation/airbus-aims-for-zero-emission-planes-by-2035>

Archived at: <https://perma.cc/8MV9-4HMN>

In a sharp increase in funding for the [Council for Civil Aviation Research] CORAC research body, France said it would invest 1.5 billion euros over three years to support research into environmentally friendly technology. The main goal of the investment would be a carbon-neutral successor to the A320, Europe's best-selling jet, with hydrogen as an energy source instead of today's oil-based gas turbines. "Our target is to have a carbon-neutral airplane in 2035 instead of 2050, thanks especially to an (ultra-efficient) engine using hydrogen," Le Maire [french finance minister] said.

<https://www.reuters.com/article/us-health-coronavirus-france-aerospace-idUSKBN23G0TB>

Archived at: <https://perma.cc/3HL5-ARRF>



Aeronautics: "The ecological transition requires a profound transformation of our industry"

*Google translation
of French webpage.*

Technical progress will not be enough to reduce greenhouse gas emissions from airplanes, essential against global warming, say more than 700 students from the aeronautics sector in a forum at the "World", who plead in favor of industrial conversions and a reduction in air traffic.

Posted May 29, 2020 at 7:30 a.m. - Updated June 25, 2020 at 2:56 p.m. | ⌚ 5 min read

https://www.lemonde.fr/idees/article/2020/05/29/aeronautique-la-transition-ecologique-impose-une-profonde-transformation-de-notre-industrie_6041127_3232.html

Archived at: <https://perma.cc/5L84-G4QN>

Biggest Emission Reduction in Aviation History Thanks to the Corona Pandemic



Ikreis, CC BY-SA, <https://bit.ly/2Jn11T0>



Traffic reduction is
more efficient than
technology



<https://stay-grounded.org>

It's about more than just CO2

Aviation must reduce its total impact on climate

Truth Decay: Right or Wrong Does Not Matter Anymore

Definitions from the book:

<u>Disinformation</u>	<u>False or misleading information spread intentionally, usually to achieve some political or economic objective, influence public attitudes, or hide the truth.</u> This is a synonym for propaganda.
<u>"Fake news"</u>	Newspaper articles, televisions news shows, or other <u>information disseminated</u> through broadcast or social media that are <u>intentionally</u> based on falsehoods or that <u>intentionally use misleading framing to offer a distorted narrative</u>

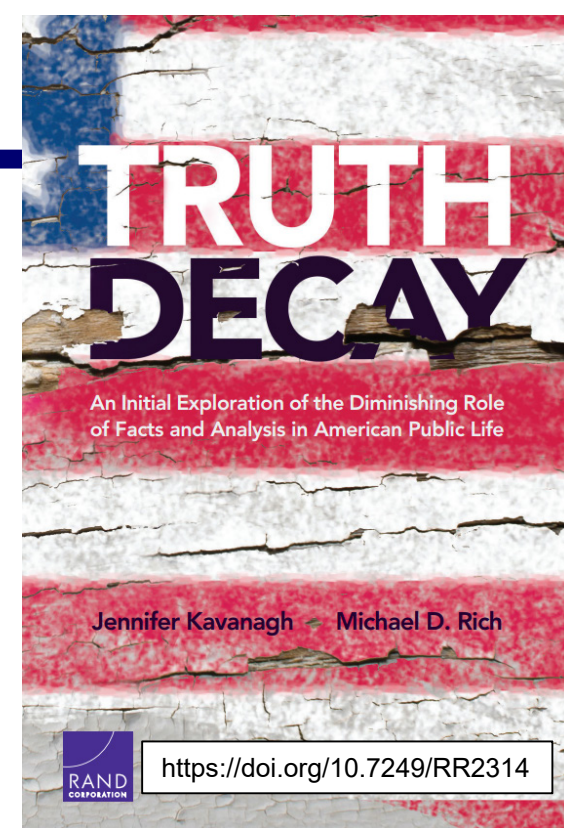

Airbus spreads misleading information ("zero emission") intentionally, which makes it "Fake News":

- Airbus knows better, because Airbus partnered the EU report "Hydrogen-Powered Aviation". (<https://doi.org/10.2843/471510>)
- Dr. Bour-Schaeffer (Airbus) knows better and has publically declared as such (RAeS Corporate Partner Briefing, 2020-11-05), only when asked, however this has not changed Airbus' official narrative or written statements.
- This is not a single event. **Airbus has distributed similarly wrong statements** e.g. **related to cabin air ventilation**: SCHOLZ, Dieter, 2020. *Airbus' Cabin Air Explanations during the Corona Pandemic – Presented, Analyzed, and Criticized*. Available from: <http://purl.org/corona/M2020-06-19> (PDF)

For more related information see:

SCHOLZ, Dieter, 2020. *Aviation Ethics – Growth, Gain, Greed, and Guilt*. German Aerospace Congress 2020 (DLRK 2020), Online, 01.-03.09.2020. Available from: <https://doi.org/10.5281/zenodo.4068009>

What Is the Hidden Strategy?

- When a strategy is hidden, **only assumptions** about it can be made. Here an attempt.
- **Airbus** has no new aircraft under development. Aircraft deliveries are down. Little work for many employees. The know-how of the workforce needs to be maintained. Salaries need to be paid. **Government** can **help** and pay (see previous pages).
- **After the Corona pandemic** the aviation world may look different. Business travel will be less, because web meeting tools are in frequent use. Private travel may not reach the growth rates as seen before.
- **With a "zero emission" aircraft an argument is prepared...**
 - **against** possible political **ideas to keep flying at low numbers** close to those during the Corona pandemic for environmental reasons,
 - **against** any other **political limitations or financial measures** for environmental reasons,
 - **to convince passengers** that flying is not that bad after all (against a bad conscience, against flight shame or flygskam),
 - **to buy time** and to continue as long as possible without further political disturbance.
- **The aircraft needs to be "zero emission"** not because it is "zero emission", but **because anything less than that will neither convince politics nor passengers.**
- **This is why a technical debate about: "How much 'zero emission' is possible?" is impossible!**

Hydrogen Powered A320

- Reduced hydrogen mass due to high mass energy density
- Stretched fuselage for additional tanks due to low volumetric energy density: 11 m
- In total: No improvement of the Maximum Take-Off Mass (MTOM)
- Steam reforming and electricity mix: SS = +300%
- Electrolysis and electricity from renewable sources: SS = -27%

Parameter	Value	Deviation from A320
Requirements		
m_{MPL}	19256 kg	0%
R_{MPL}	1510 NM	0%
M_{CR}	0.76	0%
$\max(s_{TOFL}, s_{LFL})$	1770 m	0%
n_{PAX} (1-cl HD)	180	0%
m_{PAX}	93 kg	0%
SP	29 in	0%
Main aircraft parameters		
m_{MTO}	74200 kg	1%
m_{OE}	48800 kg	18%
m_F	6200 kg	-53%
S_W	124 m ²	1%
$b_{W,geo}$	34.3 m	0%
$A_{W,eff}$	9.50	0%
E_{max}	17.00	≈ -3%
T_{TO}	100 kN	12%
BPR	6.0	0%
h_{ICA}	40000 ft	2%
s_{TOFL}	1770 m	0%
s_{LFL}	1450 m	0%
Mission requirements		
R_{Mi}	589 NM	0%
$m_{PL,Mi}$	13057 kg	0%
Results		
$m_{F,trip}$	2800 kg	-39%
SS	0.0692	300%

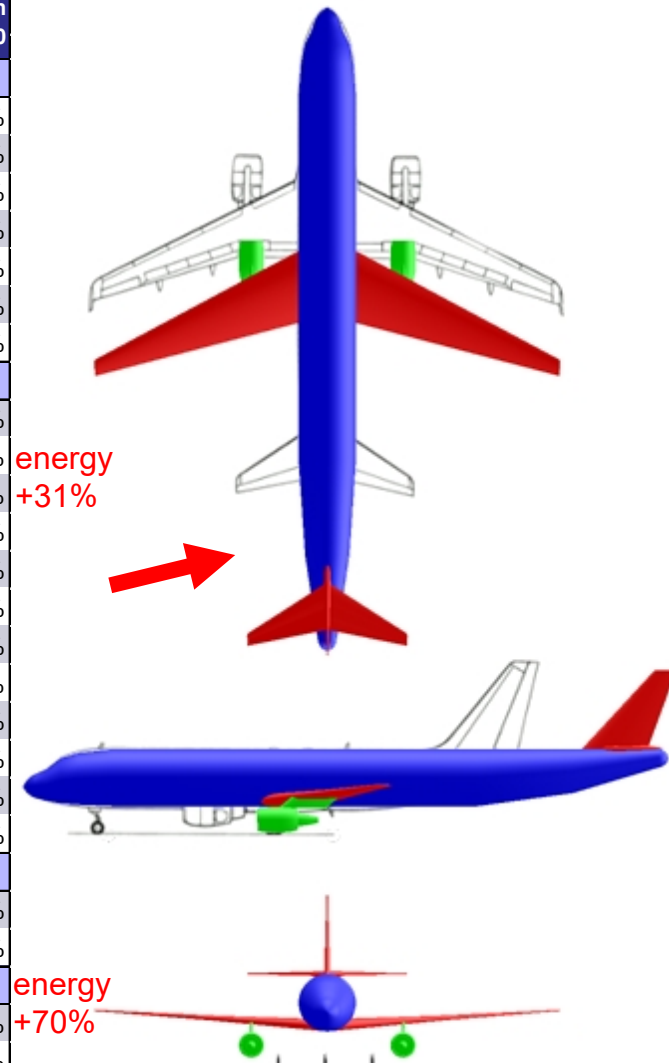

Equivalent CO₂ Mass

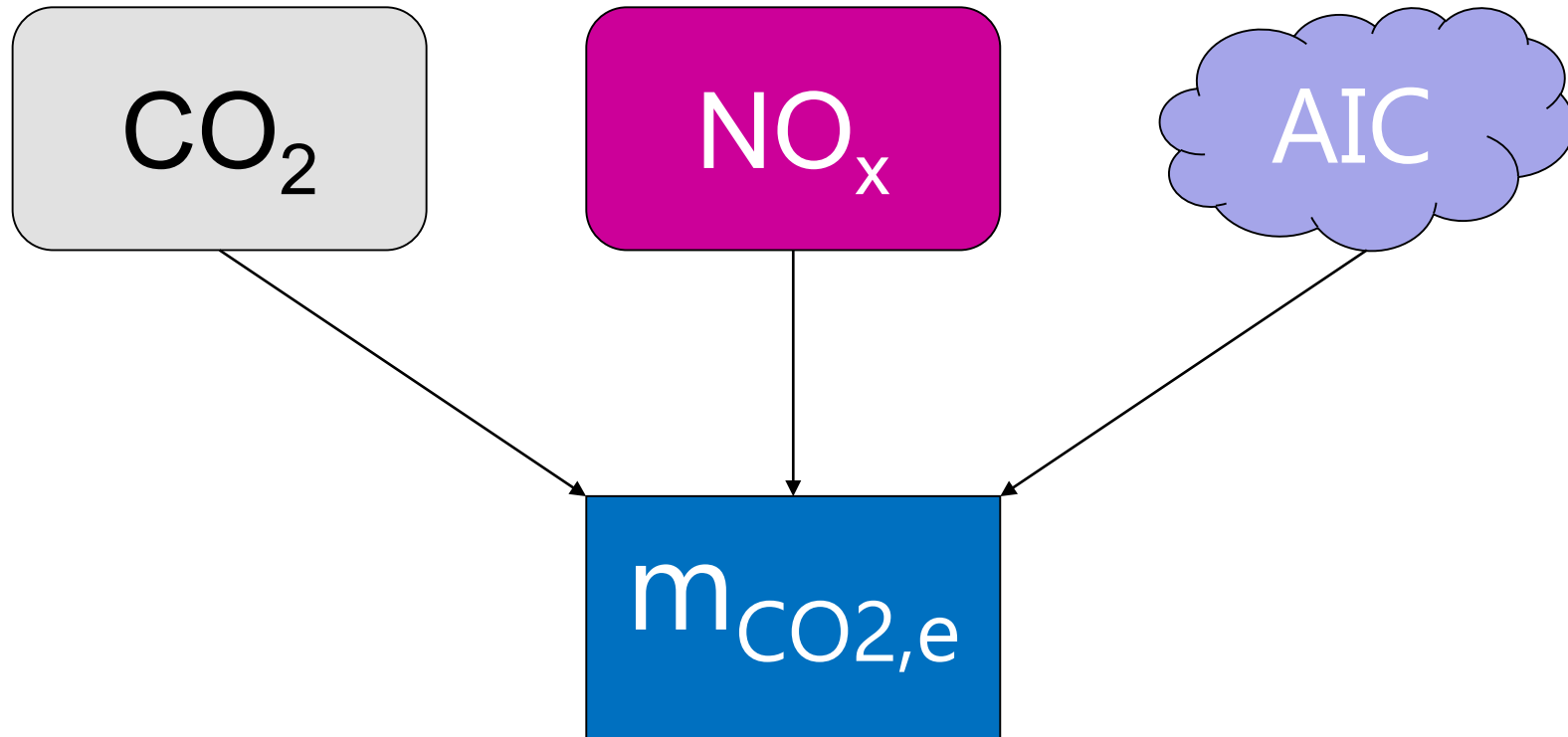

CAERS, Brecht, SCHOLZ, Dieter, 2020. *Conditions for Passenger Aircraft Minimum Fuel Consumption, Direct Operating Costs and Environmental Impact*. German Aerospace Congress 2020 (DLRK 2020), Online, 01.-03.09.2020.
 Available from: <https://doi.org/10.5281/zenodo.4068135>

Aviation Emissions and Climate Impact

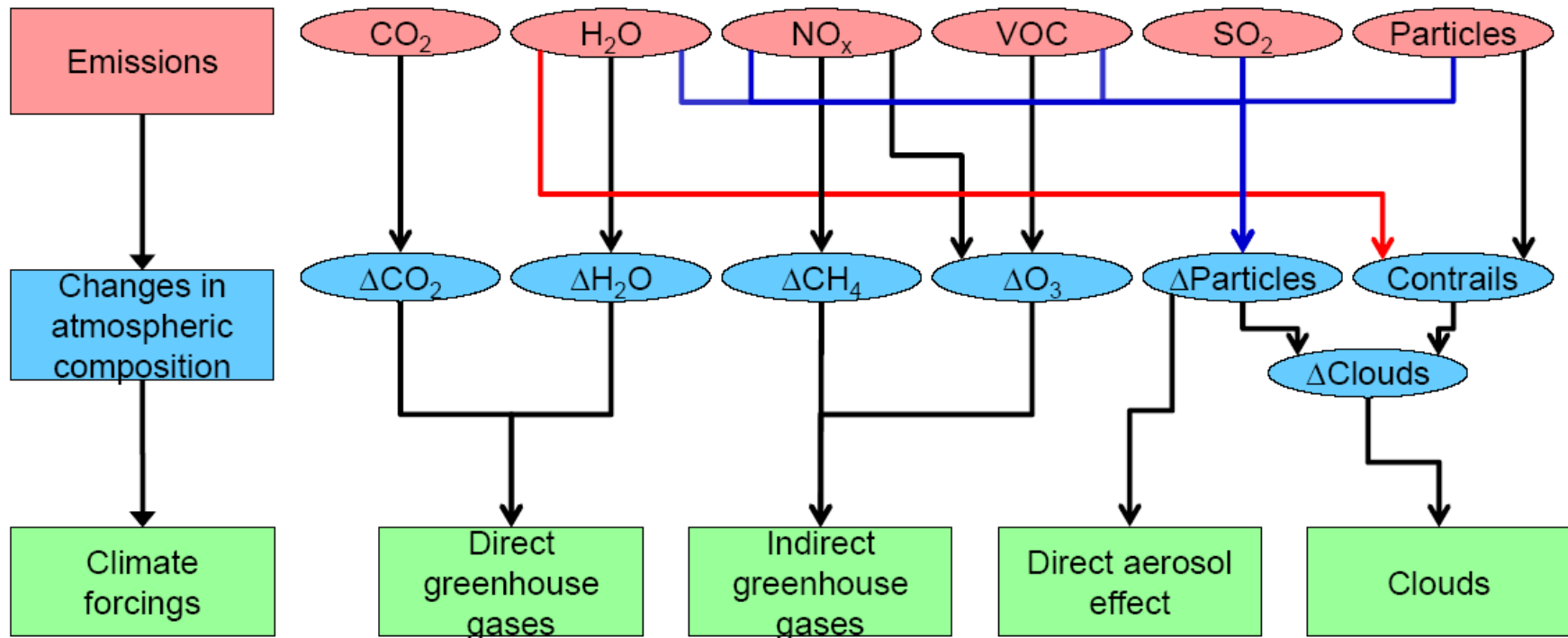

CO₂: Long term influence

Non-CO₂: Short term influence (immediate mitigation is possible)

RAPP, Markus, 2019. Perspektive: Wasserstoff & Hybride. Meeting: "Emissionsfreies Fliegen-wie weit ist der Weg?", Berlin, 13.11.2019

Altitude-Dependent Equivalent CO2 Mass

$$m_{CO_2,eq} = \frac{EI_{CO_2} \cdot f_{NM}}{n_{seat}} \cdot 1 + \frac{EI_{NOx} \cdot f_{NM}}{n_{seat}} \cdot CF_{midpoint,NOx} + \frac{R_{NM}}{R_{NM} \cdot n_{seat}} \cdot CF_{midpoint,AIC}$$

Sustained Global Temperature Potential, SGTP (similar to GWP):

$$CF_{midpoint,NOx}(h) = \frac{SGTP_{O_3s,100}}{SGTP_{CO_2,100}} \cdot s_{O_3,S}(h) + \frac{SGTP_{O_3L,100}}{SGTP_{CO_2,100}} \cdot s_{O_3,L}(h) + \frac{SGTP_{CH_4,100}}{SGTP_{CO_2,100}} \cdot s_{CH_4}(h)$$

$$CF_{midpoint,cloudiness}(h) = \frac{SGTP_{contrails,100}}{SGTP_{CO_2,100}} \cdot s_{contrails}(h) + \frac{SGTP_{cirrus,100}}{SGTP_{CO_2,100}} \cdot s_{cirrus}(h)$$

Species	Emission Index, EI (kg/kg fuel)
CO ₂	3,15
H ₂ O	1,23
SO ₂	2,00 · 10 ⁻⁴
Soot	4,00 · 10 ⁻⁵

Species	SGTP _{1,100}
CO ₂ (K/kg CO ₂)	3,58 · 10 ⁻¹⁴
Short O ₃ (K/kg NO _x)	7,97 · 10 ⁻¹²
Long O ₃ (K/NO _x)	-9,14 · 10 ⁻¹³
CH ₄ (K/kg NO _x)	-3,90 · 10 ⁻¹²
Contrails (K/NM)	2,54 · 10 ⁻¹³
Contrails (K/km)	1,37 · 10 ⁻¹³
Cirrus (K/NM)	7,63 · 10 ⁻¹³
Cirrus (K/km)	4,12 · 10 ⁻¹³

EI emission index
f_{NM} fuel consumption per NM or km
R_{NM} range in NM or km
CF characterization factor

Cirrus/Contrails = 3.0

water vapor not considered

AIC aviation-induced cloudiness

$$s_{O_3,L}(h) = s_{CH_4}(h)$$

$$s_{contrails}(h) = s_{cirrus}(h) = s_{AIC}(h)$$

Altitude-Dependent Equivalent CO2 Mass

E.g.:
$$CF_{midpoint, cloudiness}(h) = \frac{SGTP_{contrails, 100}}{SGTP_{CO_2, 100}} \cdot s_{contrails}(h) + \frac{SGTP_{cirrus, 100}}{SGTP_{CO_2, 100}} \cdot s_{cirrus}(h)$$

$$s_{contrails}(h) = s_{cirrus}(h) = s_{AIC}(h)$$

Forcing Factor $s = f(h)$

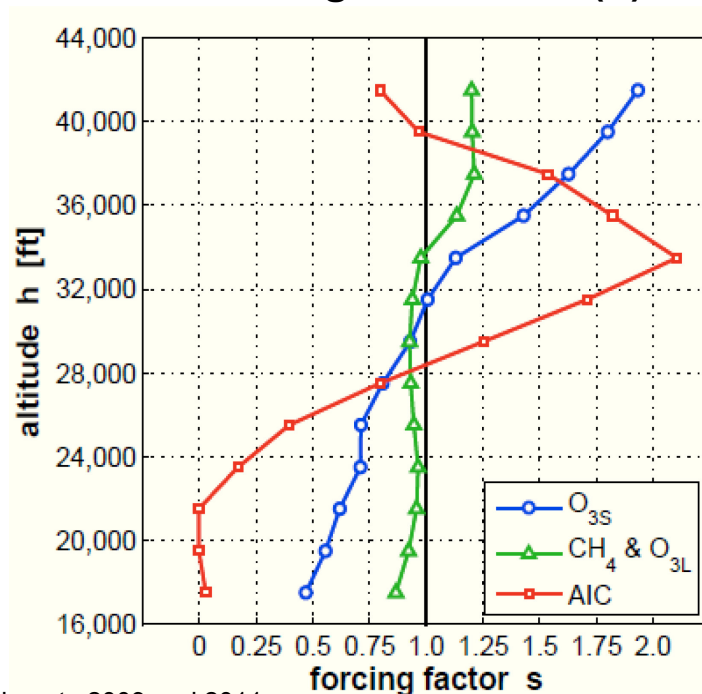

Schwartz 2009 and 2011

- The curves go along with the ICAO Standard Atmosphere (ISA) applicable for average latitudes. With a first approximation, the curves could be adapted to other latitudes by stretching and shrinking them proportionally to the altitude of the tropopause.
- The curves from SVENSSON 2004 (Fig. 1) show similar shapes. However, the importance of AIC is not yet as distinct.

SVENSSON, Fredrik, HASSELROT, Anders, MOLDANOVA, Jana, 2004. Reduced Environmental Impact by Lowered Cruise Altitude for Liquid Hydrogen-Fuelled Aircraft. In: *Aerospace Science and Technology*, Vol. 8 (2004), Nr. 4, pp. 307–320. Available from: <https://doi.org/10.1016/j.ast.2004.02.004>

Aviation-Induced Cloudiness: Contrail Cirrus & Persistent Contrails

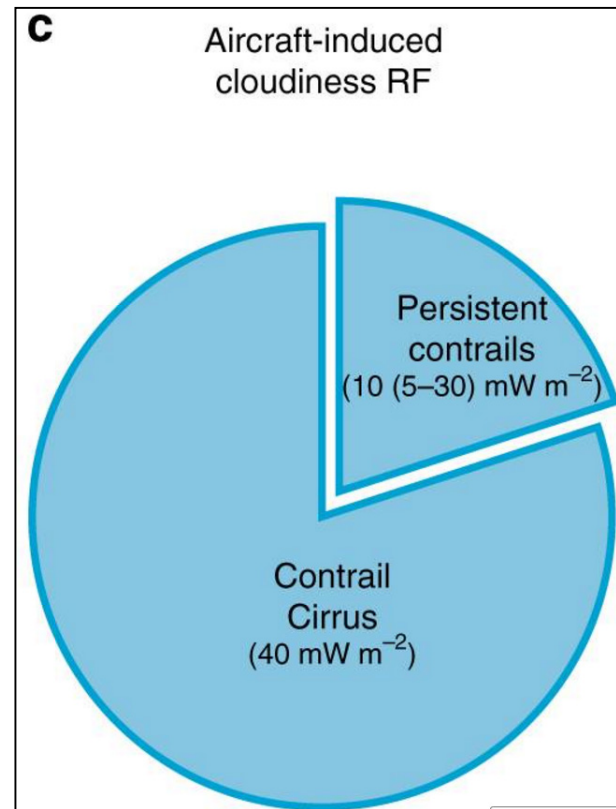
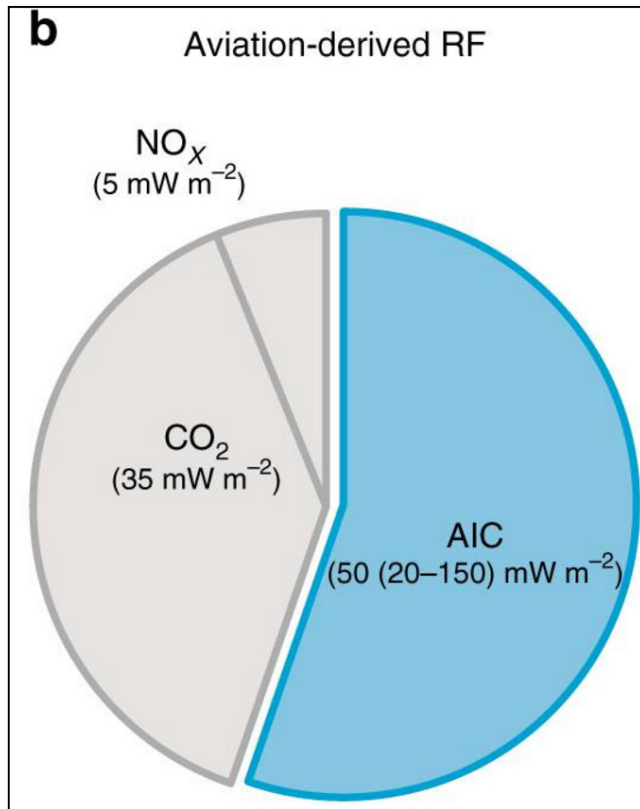

Cirrus/Contrails = 4.0

- (b) Aviation forcing components, of which aviation-induced cloudiness (AIC) account for more than half.
 (c) Breakdown of AIC radiative forcing into contrail cirrus and persistent contrails.

KÄRCHER, Bernd, 2018. Formation and Radiative Forcing of Contrail Cirrus. In: *Nature Communications*, Vol. 9, Article Number: 1824. Available from: <https://doi.org/10.1038/s41467-018-04068-0>

Schmidt-Appleman Criterion for Contrail Formation

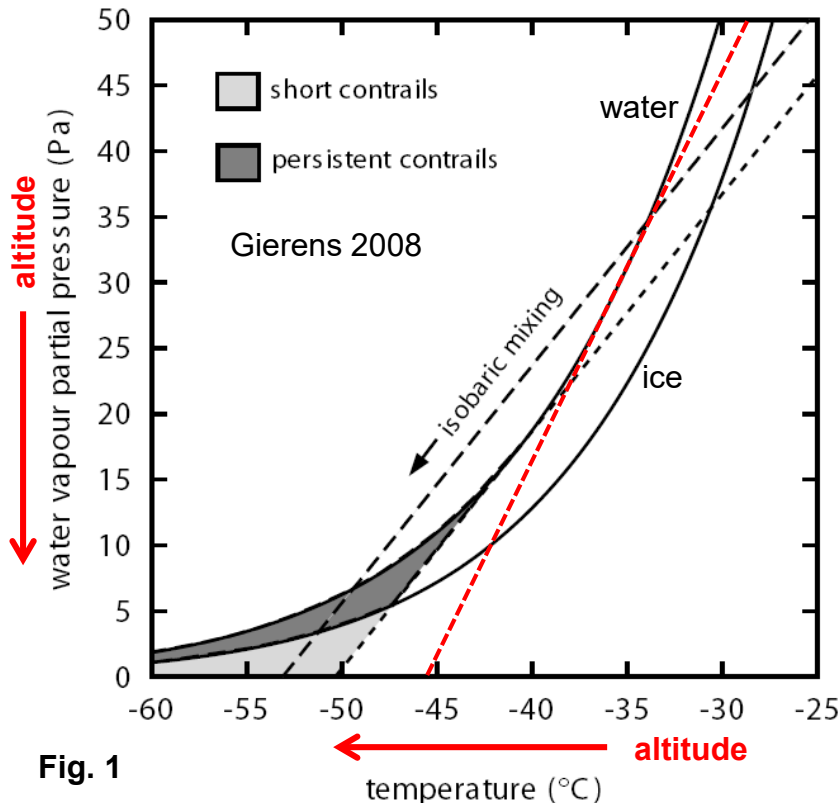

Fig. 1

G is the slope of the dotted line.
The dotted line is tangent to the water saturation line.

The mixing process is assumed to take place isobarically, so that on a T - e diagram the mixing (phase) trajectory appears as a straight line (e is the partial pressure of water vapour in the mixture, T is its absolute temperature, see Fig. (1)). The slope of the phase trajectory, G (units Pa/K), is characteristic for the respective atmospheric situation and aircraft/engine/fuel combination. G is given by

$$G = \frac{EI_{H_2O} p c_p}{\epsilon Q (1 - \eta)}$$

where ϵ is the ratio of molar masses of water and dry air (0.622), $c_p = 1004$ J/(kg K) is the isobaric heat capacity of air, and p is ambient air pressure. G depends on fuel characteristics (emission index of water vapour, $EI_{H_2O} = 1.25$ kg per kg kerosene burnt; chemical heat content of the fuel, $Q = 43$ MJ per kg of kerosene), and on the overall propulsion efficiency η of aircraft. Modern airliners have a propulsion efficiency (η) of approximately 0.35.

A steep dotted line (large G) means:
Contrails more often and also at lower altitudes.

GIERENS, Klaus, LIM, Limg, ELEFATHERATOS, Kostas, 2008. A Review of Various Strategies for Contrail Avoidance. In: The Open Atmospheric Science Journal, 2008, 2, 1-7. Available from: <https://doi.org/10.2174/1874282300802010001>

Heating Value Q, Emission Index EI, and Slope G

fuel	Q [MJ/kg]	EI _{H₂O} [kg/kg]	EI _{H₂O} /Q [kg/MJ]	G _{H₂} /G _{Jet-A1}
H2	120	8,94	0,0745	2,58
Jet –A1	43	1,24	0,0288	

The **slope G** of the dotted line is **2,58 times steeper** in case of LH2 combustion. This means: **Contrails more often** and **also at lower altitudes**.

2,58 times more water vapor is produced with LH2 combustion compared to kerosene combustion (for the same energy used).

Calculation of the Emission Characteristics of Aircraft Kerosene and Hydrogen Propulsion – A Comparison with Primary Effects

The method from SCHWARTZ 2009 was applied and adapted. Hydrogen combustion has 2.58 times more water emissions. If this primary effect is applied to aviation-induced cloudiness (AIC) with its line-shaped contrails and cirrus clouds, the equivalent CO₂ mass would be 50% higher than for kerosene. Hydrogen flame temperature is higher (without applying special technologies) and as such NO_x would be higher. It is assumed here that NO_x are the same as for kerosene. Results are calculated with an Excel table: <https://doi.org/10.7910/DVN/DLJUUK>

Altitude [ft]	rel. to kero
18000	-1%
24000	59%
30000	144%
33548	163%
36000	149%
41000	112%

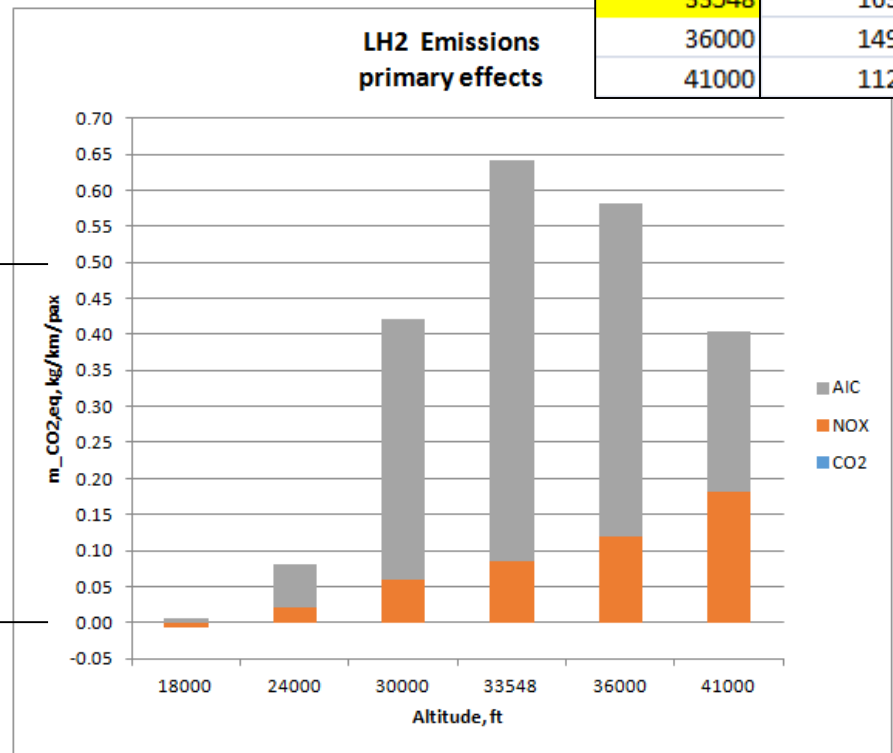
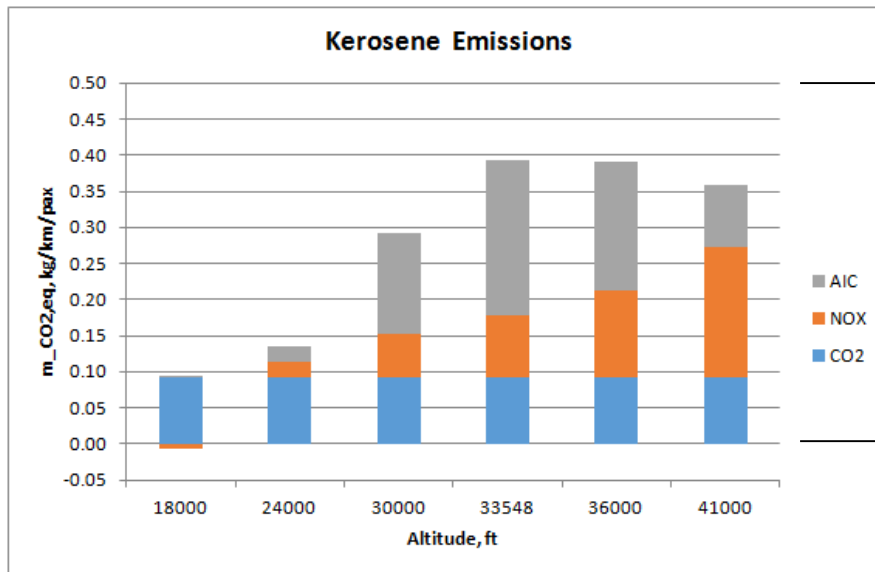

Calculation of the Emission Characteristics of Aircraft Kerosene and Hydrogen Propulsion – A Comparison with Secondary Effects

Now **secondary effects** are applied on top of the primary effect for **contrails** due to 3.333-fold larger ice crystals (factor 0.774) and for increased coverage (factor 1.2) leading all together to a **reduction factor** of $0.774 \cdot 1.2 = 0.929$. Note: This **factor** already **includes** the **2.58** for more water emissions. If the "2.58" are kept separately, the **reduction factor is 0.358!** The **same factor is assumed** for cirrus clouds. For NOx a factor of 0.35 is **assumed** due to lean combustion and low flame temperature. With that **equivalent CO2 mass is now below that for kerosene propulsion**. See Excel table: <https://doi.org/10.7910/DVN/DLJUUK>

Altitude [ft]	rel. to kero
18000	0%
24000	21%
30000	52%
33548	59%
36000	53%
41000	40%

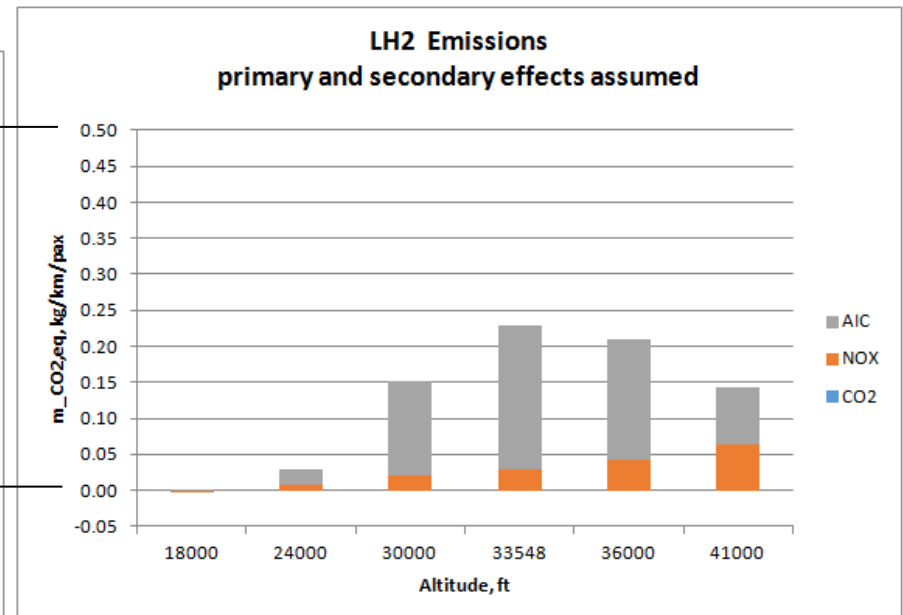
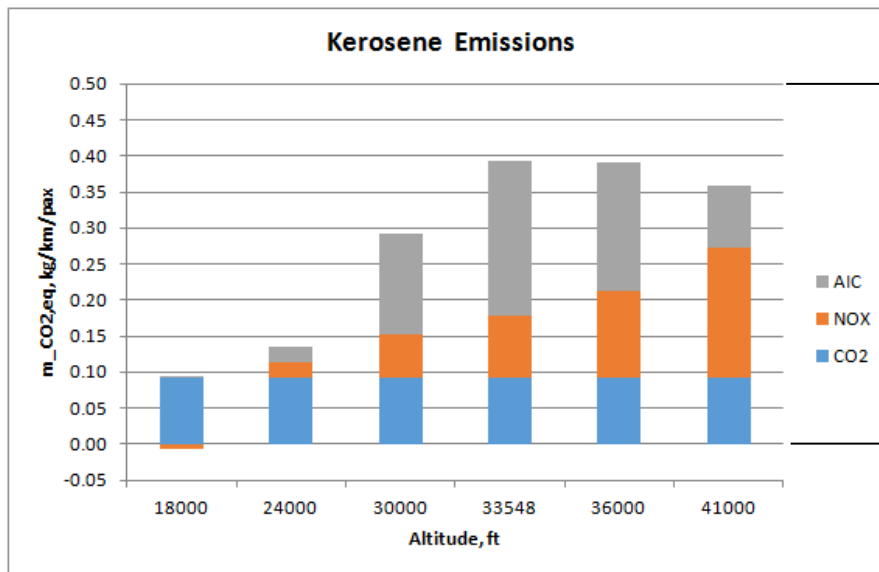

Environmental Impact – Flying Lower

		Mach number									
		0,4	0,45	0,5	0,55	0,6	0,65	0,7	0,75	0,8	
Altitude (m)	3000	0,053	0,023	0,012	0,011	0,018	0,035	0,058	0,092	0,155	
	3500	0,062	0,027	0,012	0,008	0,013	0,026	0,047	0,078	0,135	
	4000	0,072	0,032	0,013	0,006	0,008	0,019	0,037	0,064	0,117	
	4500	0,083	0,038	0,015	0,005	0,005	0,013	0,028	0,052	0,100	
	5000	0,097	0,046	0,018	0,006	0,002	0,008	0,020	0,042	0,085	
	5500	0,114	0,057	0,025	0,009	0,003	0,006	0,016	0,035	0,074	
	6000	0,133	0,068	0,032	0,012	0,003	0,004	0,012	0,028	0,065	
	6500	0,155	0,083	0,041	0,018	0,006	0,004	0,009	0,023	0,057	
	7000	0,192	0,110	0,062	0,035	0,020	0,015	0,018	0,030	0,061	
	7500	0,231	0,140	0,087	0,054	0,036	0,029	0,030	0,039	0,066	
	8000	0,282	0,180	0,119	0,082	0,060	0,050	0,048	0,055	0,079	
	8500	0,349	0,233	0,164	0,121	0,095	0,082	0,077	0,082	0,103	
	9000	0,425	0,294	0,215	0,166	0,135	0,118	0,111	0,112	0,131	
	9500	0,502	0,354	0,265	0,209	0,173	0,153	0,142	0,141	0,157	
	10000	0,589	0,422	0,320	0,256	0,215	0,190	0,176	0,172	0,184	
10500	0,675	0,481	0,364	0,289	0,241	0,211	0,193	0,186	0,196		
11000	0,685	0,483	0,361	0,284	0,234	0,203	0,185	0,178	0,189		
11500	0,769	0,535	0,394	0,305	0,247	0,211	0,188	0,178	0,186		
12000	0,867	0,591	0,426	0,322	0,255	0,211	0,184	0,170	0,175		
12500	1,000	0,677	0,485	0,364	0,285	0,234	0,201	0,183	0,184		

“Neutral” mix of 50 – 50 resource depletion and engine emissions

Clear altitude boundary from $m_{CO2,eq}$ visible

Fuel consumption shape visible

Fly low and slow

Units: normalized value between 0 and 1

AIRCRAFT DESIGN AND SYSTEMS GROUP (AERO)

Zero Emission – The New Credo in Civil Aviation

Internal: Cabin Ventilation Against the Corona Virus

External: CO₂, NO_x, AIC

Dieter Scholz Hamburg University of Applied Sciences

German Aerospace Congress 2021 (DLRK 2021)

Online, 01 September 2021

<https://doi.org/10.5281/zenodo.5919013>

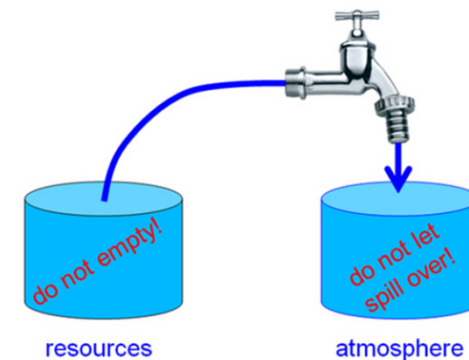

Zero Emission – The New Credo in Civil Aviation

Internal Emissions: Cabin Ventilation Against the Corona Virus

These slides summarize and extend a lecture from the DGLR local branch Hamburg. For a few more details see:

<https://doi.org/10.5281/zenodo.5356568>

Internal: Cabin Ventilation Against the Corona Virus

HEPA Filter



Airbus A380, Emirates. Installing a new HEPA filter. High risk operation?

Zero Emission – The New Credo in Civil Aviation

External Emissions: CO₂, NO_x, AIC

This is part draws from the HAW Report "Umweltschutz in der Luftfahrt" (Environmental Protection in Aviation).
For many more details see:

<https://nbn-resolving.org/urn:nbn:de:gbv:18302-aero2021-07-03.015>

External Emissions: CO₂, NO_x, AIC

"Green Deal" (2050) and "Fit for 55" (2030)

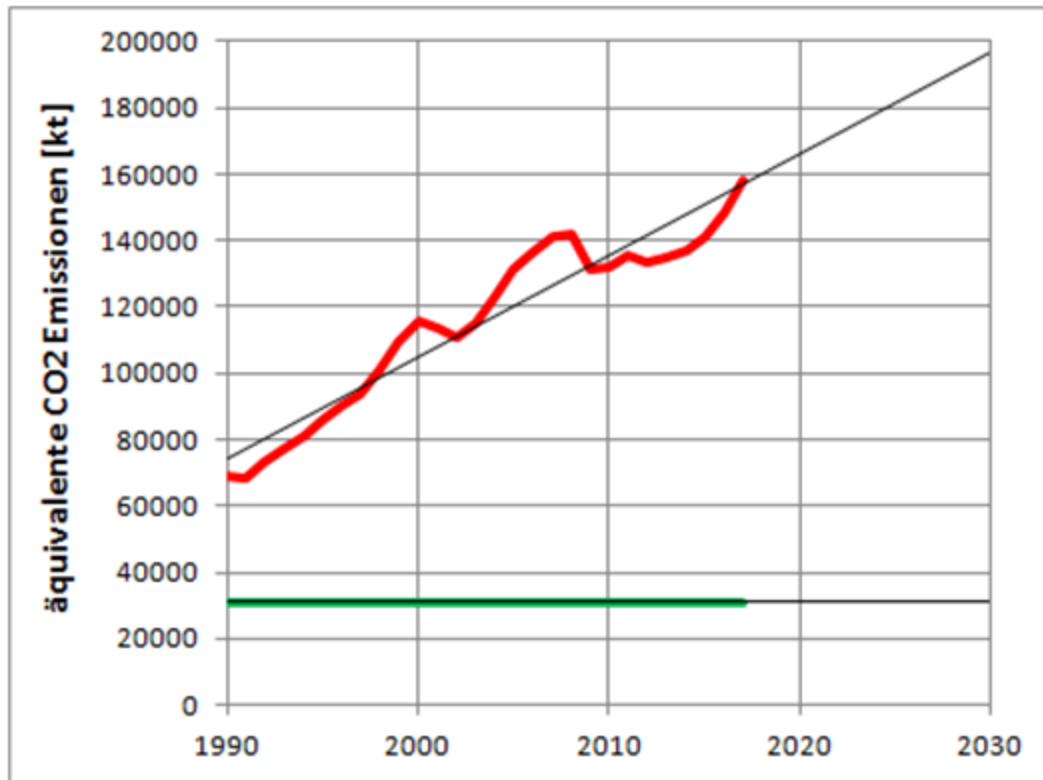

The **equivalent CO₂ emissions** (in 1000 tonnes or kt) **of international aviation** in the EU are **rising continuously** (red line). According to the "Green Deal" of the EU, the to 45% of the 1990 value (by 2030) (green line). Diagram created with data from. EEA 2019 (<https://perma.cc/2EZ6-DQBN>)

External Emissions: CO₂, NO_x, AIC

The Carbon Cycle

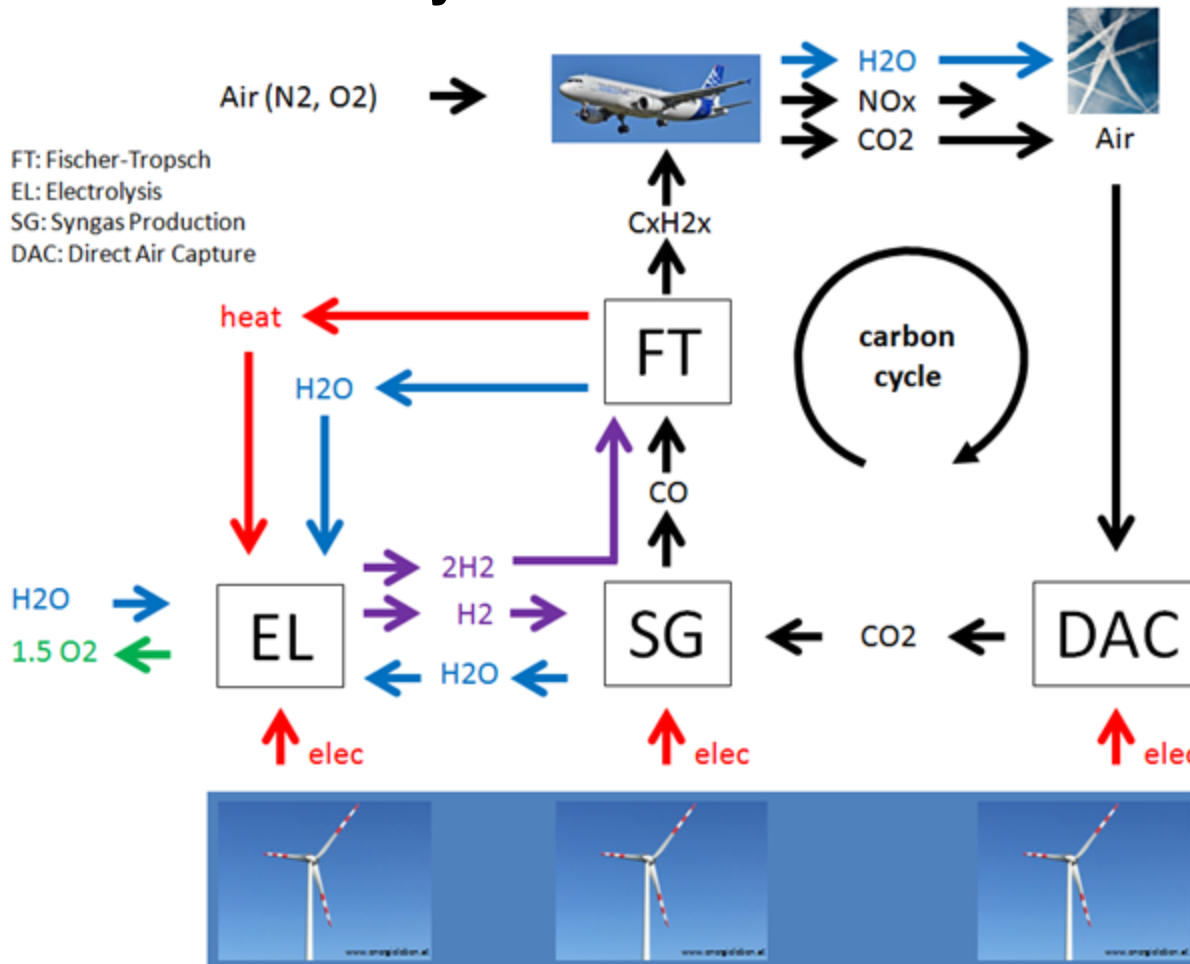

- SAF need DAC (Direct Air Capture) to compensate for CO₂ ("carbon cycle")
- In addition: SAF and BioFuel need more DAC to compensate for the global warming effect due to
 - NO_x and
 - H₂O (AIC)

Production of synthetic kerosene (e-fuel) with power-to-liquid (PtL). Taking CO₂ from the air (Direct Air Capture, DAC) enables a carbon cycle.

External Emissions: CO₂, NO_x, AIC

Best Use Renewable Energy to Replace Coal Power Plants

Substituting coal
is better by a factor of $0.9/0.057 = 15.7$

The idea using PtL fuels in aviation

<http://ptl.ProfScholz.de>

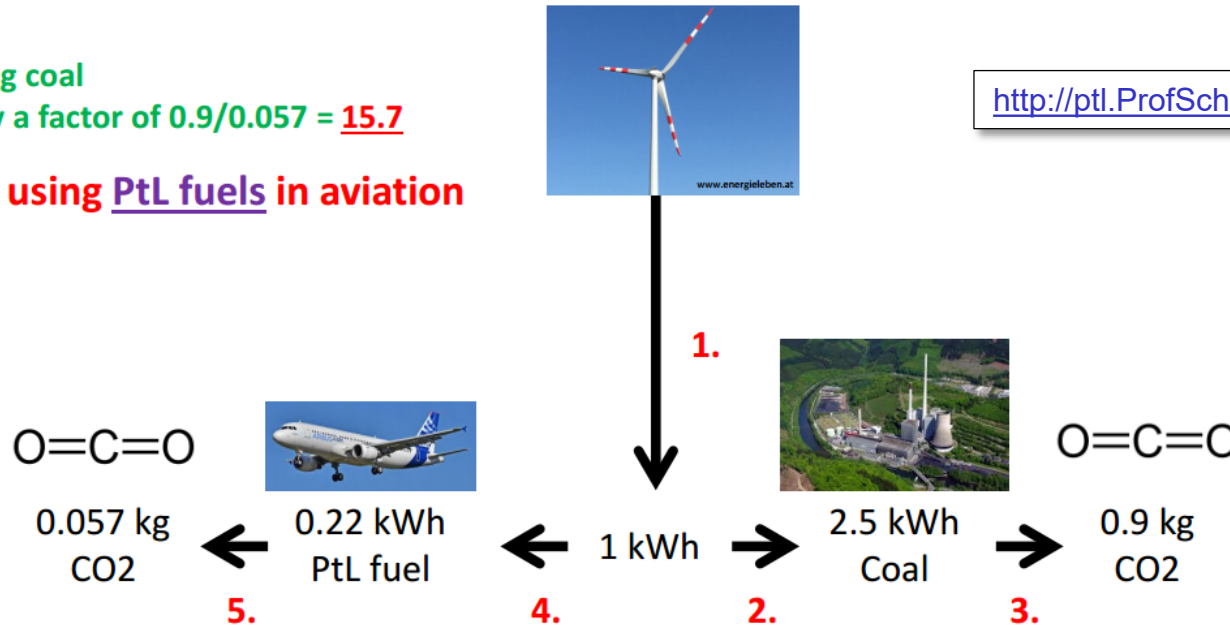

- 1.) 1 kWh of renewable energy ...
- 2.) ... can replace 2.5 kWh lignite in coal-fired power plants (efficiency 40%);
- 3.) This corresponds to 0.9 kg of CO₂ (0.36 kg of CO₂ for 1 kWh of energy from lignite *).
- 4.) ... converted into Sustainable Aviation Fuel (SAF) only 0.22 kWh remain (efficiency: 70% electrolysis, 32% Fischer-Tropsch), 99% transport; <https://perma.cc/BJJ6-5L74>
- 5.) which save only 0.057 kg of CO₂ (0.26 kg of CO₂ for 1 kWh of kerosene *).

* UBA, 2016: CO₂ Emission Factors for Fossil Fuels. <https://bit.ly/3r8avD1>

External Emissions: CO₂, NO_x, AIC

Best Use Renewable Energy to Replace Coal Power Plants

Substituting coal
is better by a factor of $0.9/0.14 = 6.3$

The idea using LH2 in aviation

<http://ptl.ProfScholz.de>

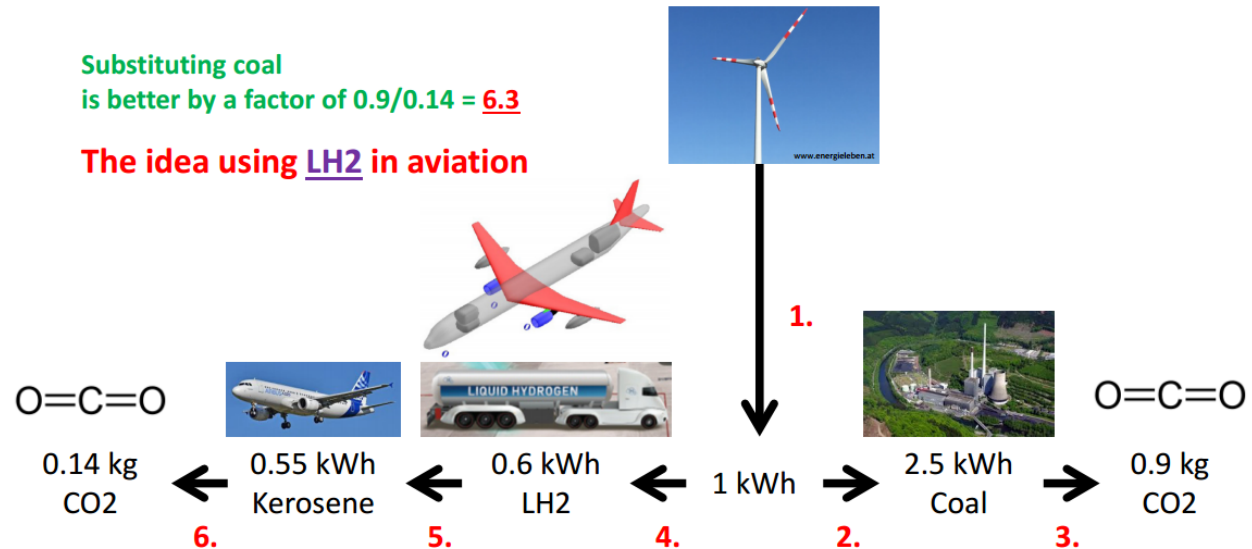

- 1.) 1 kWh of renewable energy ...
- 2.) ... can substitute 2,5 kWh of coal (lignite, brown coal) in a coal power plant (efficiency of a coal power plant: 40%) this is
- 3.) ... equivalent to 0.9 kg CO₂ (0.36 kg CO₂ for 1 kWh of energy burning lignite*)
- 4.) ... but if used in an aircraft it generates LH₂ with energy of 0.6 kWh (efficiencies: 70% electrolysis, 83% liquefaction & transport)
- 5.) LH₂ aircraft consume (say) 10% more energy (higher operating empty mass, more wetted area); so a kerosene aircraft needs ...
- 6.) only 0.55 kWh, which can be substituted. This is equivalent to 0.14 kg CO₂ (0.26 kg CO₂ for 1 kWh of energy burning kerosene*).
- 7.) Note: Not considered is that hydrogen aircraft may come with higher non-CO₂ effects than kerosene aircraft.

* UBA, 2016. CO₂ Emission Factors for Fossil Fuels. Available from: <https://bit.ly/3r8avD1>

External Emissions: CO2, NOX, AIC

Aircraft Fuel Consumption – Short Range Not Efficient

Use the Train!

- Train is about 3 times more energy-efficient (certainly on short range)
- Train uses 50% Eco Electricity Mix (factor 2)
- Aircraft Factor 3, because in addition non-CO2 effects from:
 - NOX and
 - H2O (AIC)
- 3*2*3: aircraft is 18 times worse

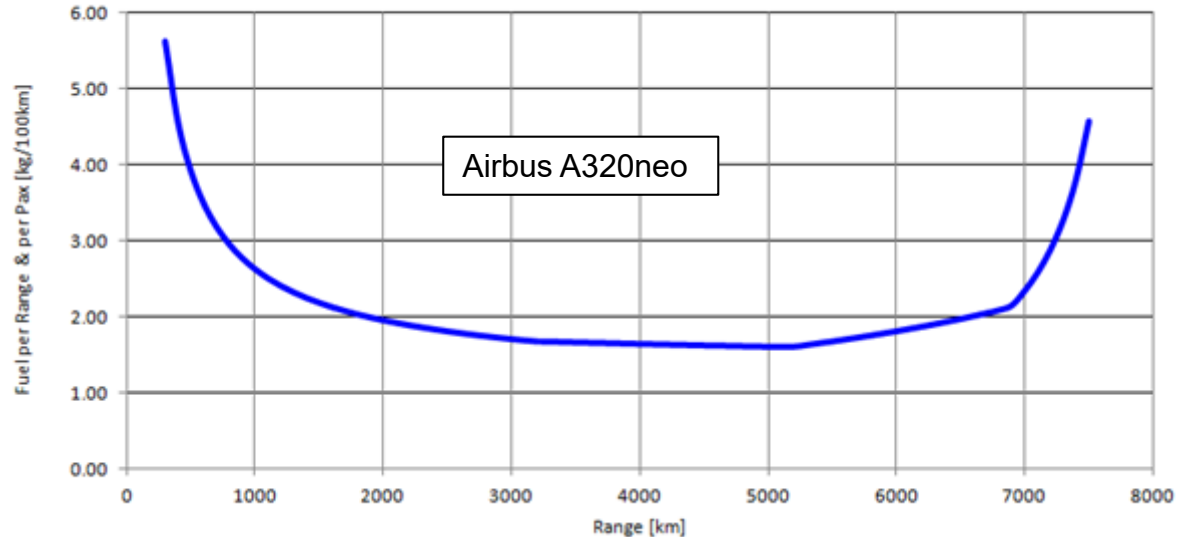

Simple Calculation of Aircraft Fuel Consumption with Public Data:

See details: <https://bit.ly/3mWHo6c>

$$Fuel\ Consumption = (MTOW - MZFW) / (R \cdot Seats) \cdot 100$$

R: Range at maximum payload, from payload range diagram (Document for Airport Planning).

Example calculation with Airbus A320neo:

$$2.2\ kg\ per\ 100\ km\ per\ seat = (73500\ kg - 62800\ kg) / (3180\ km \cdot 150) \cdot 100$$

External Emissions: CO2, NOX, AIC

Industry Strategy – Presented by InfluenceMap, 2021, June

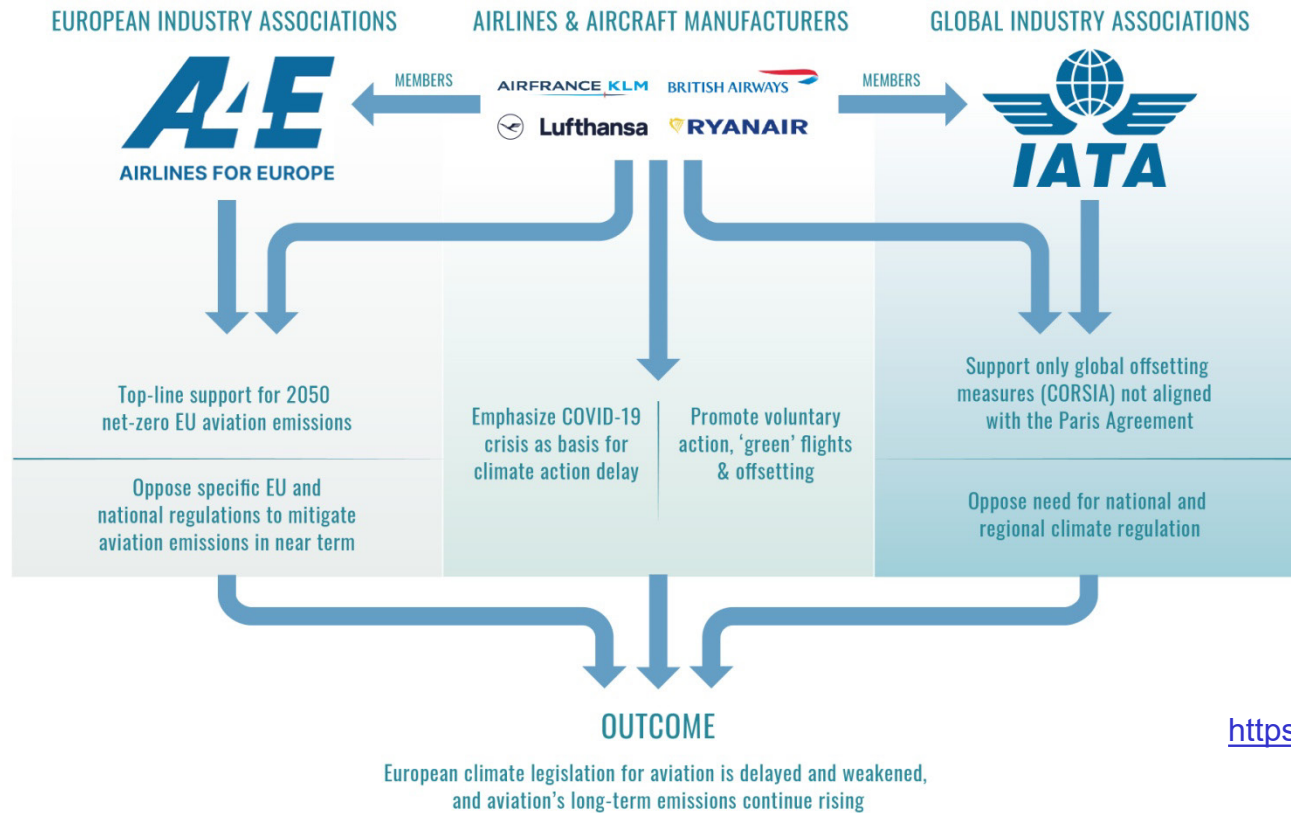

<https://perma.cc/82VC-KEBR>

KEY

- LOBBYING AT EUROPEAN LEVEL (EU & STATES)
- PR & COMMUNICATIONS STRATEGY
- LOBBYING AT GLOBAL LEVEL (UN ICAO)

External Emissions: CO₂, NO_x, AIC

Airbus – Past Technology Timeline



1995-08-30

DASA plans to fly Dornier 328 with hydrogen power in 1998

<https://perma.cc/RF4R-LS8R>

... but nothing happend!

External Emissions: CO2, NOX, AIC

Technology Timeline – Airbus' EU Briefing, 2021-02-09

A hydrogen replacement of the A320 will NOT come before 2050!

Indicative overview of where CO₂ measures could be deployed globally

	2020	2025	2030	2035	2040	2045	2050	
Commuter » 9-50 seats » <60 minute flights » <1% of industry CO ₂	SAF	Electric and/or SAF	Electric and/or SAF	Electric and/or SAF	Electric and/or SAF	Electric and/or SAF	Electric and/or SAF	~27% of CO ₂ emissions
Regional » 50-100 seats » 30-90 minute flights » ~3% of industry CO ₂	SAF	SAF	Electric or hydrogen fuel cell and/or SAF	Electric or hydrogen fuel cell and/or SAF	Electric or hydrogen fuel cell and/or SAF	Electric or hydrogen fuel cell and/or SAF	Electric or hydrogen fuel cell and/or SAF	
Short-haul » 100-150 seats » 45-120 minute flights » ~24% of industry CO ₂	SAF	SAF	SAF	SAF	Electric, hydrogen combustion and/or SAF	Electric, hydrogen combustion and/or SAF	Electric, hydrogen combustion and/or SAF	
Medium-haul » 100-250 seats » 60-150 minute flights » ~43% of industry CO ₂	SAF	SAF	SAF	SAF	SAF	SAF	SAF potentially some Hydrogen	~73% of CO ₂
Long-haul » 250+ seats » 150 minute + flights » ~30% of industry CO ₂	SAF	SAF	SAF	SAF	SAF	SAF	SAF	

www.airbus.com AIRBUS

<https://perma.cc/2G6J-76DA>

AIRCRAFT DESIGN AND SYSTEMS GROUP (AERO)

Social Evaluation of Aircraft Projects

Example Airbus A380

Dieter Scholz Hamburg University of Applied Sciences

Deutscher Luft- und Raumfahrtkongress 2022

27. – 29. September 2022

<https://purl.org/aero/PRE2022-09-27>



Social Evaluation of the A380 Local Population



50 acres of orchards and several houses were destroyed: Preparation for the extension of the runway in the year 2006. In the foreground the village Neuenfelde.

<https://perma.cc/2AYS-KALD>
<https://perma.cc/NC8W-BAMC>

Social Evaluation of the A380 Local Population

before



Cultural Heritage
(Rosengarten)

after



Source:
Infoboard next to the house Rosengarten 14, 21129 Hamburg-Neuenfelde

Social Evaluation of the A380 Local Population

before



Cultural Heritage
(Rosengarten)

after



Source:
Infoboard next to the house Rosengarten 14, 21129 Hamburg-Neuenfelde

Social Evaluation of the A380 Local Population



The **extension of the runway** in Hamburg-Finkenwerder towards southwest is **ready** (Google 2021)

The **extension of the runway** was paid by the city of Hamburg!

**Airbus ist nach zahlreichen Lügen,
Widersprüchen, diversen Gutachten und
einem konstruierten „Worst Case Scenario“
letztendlich nur eins geblieben:**

Die 410 t Landelüge !

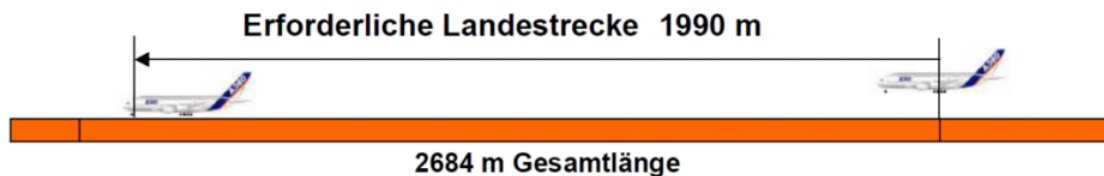

Translation:

After several lies, contradictions, various opinions/assessments and a fabricated "Worst Case Scenario" only one thing finally remained to Airbus:

The 410 t landing lie !

Background to the figure:

For a required landing field length (including reserves) even at 410 t landing mass of the Airbus A380 (resulting in 1990 m) the available landing distance (LDA) of the old runway (2684 m) was sufficient at a displaced threshold of 478 m based on a 3.5° glide slope).

The runway extension forced in place against much local resistance was unnecessary.

Further reading:

Project (en): <https://nbn-resolving.org/urn:nbn:de:gbv:18302-aero2021-12-16.012>

Source:

Report (de): <https://nbn-resolving.org/urn:nbn:de:gbv:18302-aero2022-03-15.018>

Social Evaluation of the A380 Local Population

Community Engagement (Runway, Mühlenberger Loch, Hasselwerder Str.)



During a meeting on the farm of family Eck in Neuenfelde, village people discuss about their resistance against the extension of the runway and the destruction of the ecosystem of the river bay "Mühlenberger Loch" for Airbus.

<https://perma.cc/SP35-EH8W>

AIRCRAFT DESIGN AND SYSTEMS GROUP (AERO)

Aviation Ethics – Growth, Gain, Greed, and Guilt

Dieter Scholz

Hamburg University of Applied Sciences

<https://doi.org/10.5281/zenodo.4068009>

Deutscher Luft- und Raumfahrtkongress 2020

German Aerospace Congress 2020

Online, 01 - 03.09.2020

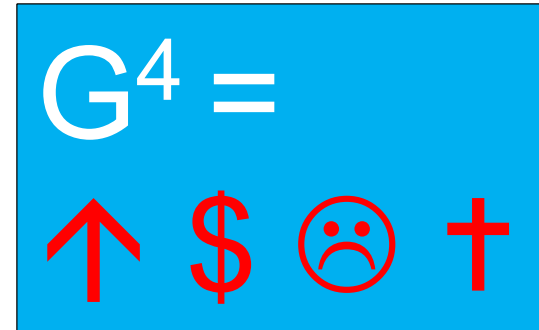

Definitions

(Revenue) **growth** is the increase (or decrease) in a company's sales from one period to the next. It shows trends in the business.

<https://www.business-literacy.com/financial-concepts/revenue-growth>

German: **Wachstum** (der Umsätze)

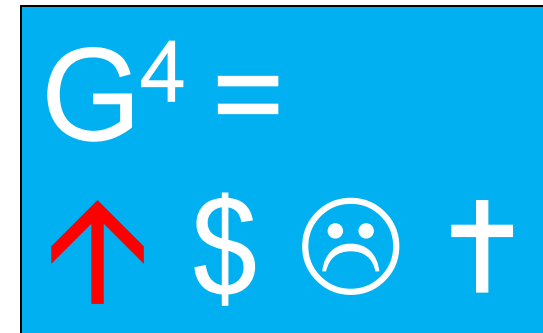

Definitions

An exchange profit or a favorable stock price change leads to a **gain**.
 A **profit** is similar: the difference between revenues and expenses

German: **Gewinn**

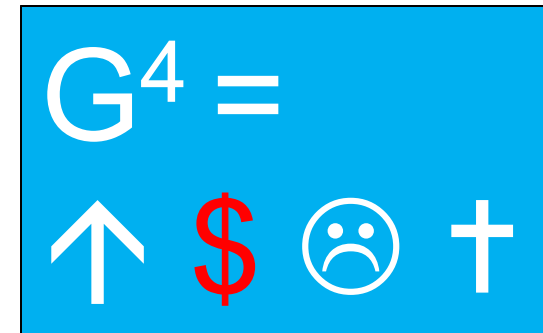

Definitions

Greed: A selfish and excessive desire for more of something (such as money) than is needed.

<https://www.merriam-webster.com/dictionary/greed>

German: **Gier, Habsucht**

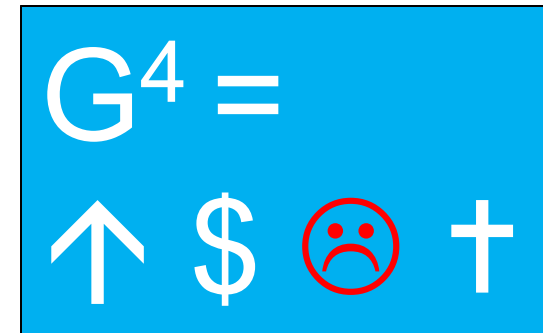

Definitions

Guilt: the fact of having committed a breach of conduct especially violating law and involving a penalty.

<https://www.merriam-webster.com/dictionary/guilt>

German: **Schuld**

The symbol † stands for the highest guilt, to have caused the death of a person.

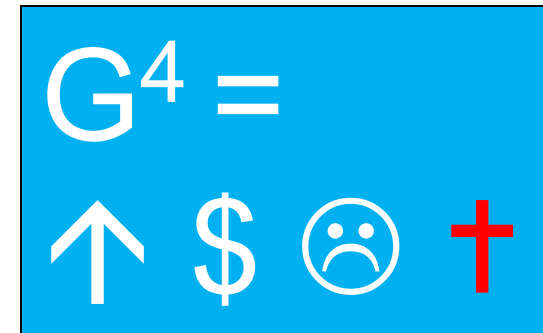

Philosophy – Business Ethics

Business ethics regulates details of behavior that lie beyond governmental control (i.e. not controlled by laws and regulations).

The opposite: "unethical business practice". It *includes*:

- **contract violation**,
- **anticompetitive agreement** to raise the price,
- **conspiracy** against the public,
- **deceitful practices**,
- ...

Danger to run into this **negative sequence**: $G^4 = \uparrow \$ \text{☹} †$

Continuous **growth** to increase **gain** to satisfy shareholders expectations can lead to **greed** and to an ever more ruthless industry behavior accumulating **guilt** in the end.

Infamous examples ... later.

Philosophy – Cascade of Obedience to the Law

Possible **hidden company policies** related to **legal responsibilities** as part of **business ethics**:

- 
- 1) abide by the **law**, only if it is **enforced** to the **detriment** of the company
 - 2) abide by all **law** that is **enforced** (even if punishment is mild)
 - 3) abide by all **law** (enforced or not)
 - 4) abide by the **law and the code of respectable businessmen**
(German: Verhalten als "ehrbarer Kaufmann").

better behavior

Business Ethics Case Studies

Case Study: Ford Pinto (The Classic Case of CSR Failure)

- The Pinto's design positioned its **fuel tank** between the rear axle and the rear bumper.
- Ford Pintos were consumed by **fire after** low-speed rear-end **collisions**.
- Engineers did a cost–benefit analysis:
 - Ford estimated the **cost** of fuel system modifications to reduce fire risks to be \$11 per car across 12.5 million cars for a total of **\$137 million**.
 - The design changes were estimated to save **180 burn deaths and 180 serious injuries** per year, a benefit to society of only **\$49.5 million**.
 - Therefore, nothing was done!
- **Ford was blamed** for callously **trading lives for profits**.
- Approximately 117 lawsuits were brought against Ford.

https://en.wikipedia.org/wiki/Ford_Pinto

Compare the following aviation cases with this "classic" one!

Case Study: Airbus – € 3.6 Billion Penalty Due to Bribery

- "Airbus has agreed to pay a € 3.6 billion fine to **settle multiple investigations from French, UK and US.**"
- A "€ 3.6 billion penalty imposed through a deferred prosecution agreement to settle allegations of **failure to prevent bribery** in a number of commercial and military aircraft deals."
- Airbus used **third-party intermediaries**, working on commission, to assist with sales campaigns.
- Airbus admitted that "it **could be excluded from** government or other **contracts** for some time." The company could take a major hit affecting aircraft sales and cash flow. "In the worst case, the total future **revenue at risk** could exceed **€200 billion.**"
- "We want this **[fully-compliant policy] to be the norm** and I observe that there are many, many regions of the world where the majority of players want to go in that direction" says Faury.
- "We'll make sure we are visible as a company **working with compliance**, with **rules** and **regulations**".

Sources: **flightglobal.com**: **Archived at**: <https://perma.cc/MC88-BZUQ>, <https://perma.cc/U7Y8-GJSS>
<https://perma.cc/6F8V-ANTA>, <https://perma.cc/Z999-SB2W>,
handelsblatt.com: **Archived at**: <https://perma.cc/N85T-JUDF>

Case Study: Boeing – B737 MAX

- In March 2019, the Boeing 737 MAX passenger airliner was grounded worldwide after **346 people died in two crashes** on October 29, 2018 and on March 10, 2019.
- In November 2018 Boeing revealed the MAX had a new automated flight control, the **Maneuvering Characteristics Augmentation System (MCAS)**. **Boeing had omitted any mention of the system from the aircraft manuals!**
- MCAS is activated by input from only one of the airplane's two angle of attack sensors, making the **system susceptible to a single point of failure**.
- **Transport Airplane Risk Assessment Methodology (TARAM)**: "if left uncorrected, the MCAS design flaw in the 737 Max could result in as many as 15 future fatal crashes over the life of the fleet"
- **Boeing was also already well aware, before the first crash, that** if a pilot did not react to unintended MCAS activation within 10 seconds, **the result could be catastrophic**.
- The **grounding cost Boeing \$18.6 billion** in compensation to airlines and victims' families.

Sources: **Wikipedia** <https://en.wikipedia.org> (several pages)
Seattle Times **Archived at:** <https://perma.cc/5KSP-BRZ9> (summary with further links)

Case Study: Lufthansa & Others – Delayed Ticket Refunds

- The flight has long been paid for, but the plane never has because of the pandemic. Nevertheless, **many customers have not received the ticket price refund for months.**
- Lufthansa has received nine billion euros in **government aid**. Aid money has also flown so that the customer money can be repaid!
- If a flight is canceled, the **company must repay the ticket price within seven days** (EU Air Passenger Rights Regulation).
- Apparently, Lufthansa wants to prevent drain of liquidity – **even if it gets more expensive later in court.**
- **Airlines have turned off its automatic reimbursement system.** It was a simple process before Corona – the funds were booked back usually immediately after a flight cancellation.
- The Federal Aviation Office (LBA) can impose **finer** for violations of the passenger rights directive (**up to 30000 € per case**) and even threaten to withdraw the operating license.
- The LBA has initiated administrative offense proceedings against suspicious aviation companies. The proceedings are still ongoing.

Source: **WELT Online** [Archived at: https://perma.cc/HMK8-DVR8](https://perma.cc/HMK8-DVR8)

Other Unethical Issues

- 2020: **Lufthansa avoids tax payments in Germany** with subsidiaries based in countries or territories that appear on the EU list of non-cooperative countries and territories for tax purposes. (<https://perma.cc/MJ9P-NDX5>)
- 2020: **Ryanair** busted over **misleading 'low CO2' claims**. (<https://perma.cc/4WLX-YEAF>)
- 2019: **Airbus** under pressure for not doing enough against "**fumes that are making people sick**". (<https://perma.cc/7CC9-BGYZ>)
- 2017: Israel Aerospace Industries, **IAI corruption scandal**. (<https://perma.cc/J7ZK-DEYG>)
- 2017: **United** overbooks. As a consequence it denies boarding or even **drags passengers off the plane**. (<https://perma.cc/TVH9-ULTT>)
- 2017: **Boeing's** aggressive **anti-union campaign**. (<https://perma.cc/7KX9-GCZX>)
- 2015: Relatives accuse **Lufthansa/Germanwings** years after the crash of the Germanwings flight 4U9525 to **avoid sufficient compensation payments**. Compensation – 25000 € per victim and 10000 € each for close relatives because of the victims pain – would be insufficient. (<https://perma.cc/C8ED-JLQ4>, <https://perma.cc/DA7A-LHD7>)
- 2012: **Ryanair ordered to 'review' fuel policy** after making three emergency landings because planes almost ran out of fuel. (<https://perma.cc/S5BL-XW56>)
- 2006: **Boeing** to pay \$615 million to end **Pentagon scandals**. Allegations that Boeing improperly acquired thousands of pages of proprietary documents from rival Lockheed Martin to help it win rocket contracts. (<https://perma.cc/5DMZ-988C>)

This is an excerpt from student 's results about ethical and unethical behavior in aviation.

Summary

$$G^4 = \uparrow \$ \text{☹} †$$

- There is a danger for companies to run into this **negative sequence**: "Continuous **growth** to increase **gain** to satisfy shareholders expectations can lead to **greed** and to an ever more ruthless industry behavior accumulating **guilt** in the end."
- There is a **cascade of obedience** to the law. **The aviation industry is far from abidance by the law** and far from taking up the **code of a respectable businessman**.
- The **list of wrongdoing** in the aviation industry is long:
 - bribery
 - trading lives for profit
 - avoiding payments:
 - tax, compensation, refund,
 - lying about safety critical issues:
 - cabin air quality
 - cabin air ventilation / risk of an infection on board
 - making misleading claims
 - greenwashing

Recommended Reading

The Guardian:

"Boeing's Travails Show What's Wrong With Modern Capitalism"

(<https://perma.cc/2AFL-B5G3>)



"Boeing used its political connections to monopolize the American aerospace industry and corrupt its regulators."

"After the merger [with McDonnell Douglas], the engineers lost power to the financiers."

"Far from being an anomaly, Boeing is the norm in the corporate world across the west."

"Today, high profit margins are a pervasive and corrupting influence across the government and corporate sectors."

"Policymakers have to increase competition for large powerful companies, to bring profits down. Executives should spend their time competing with each other to build quality products, not finding ways of attracting former generals, or administration officials to their board of directors."

Contact

info@ProfScholz.de

<http://www.ProfScholz.de>